

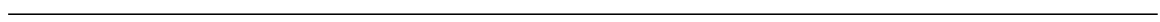

PrintNet Enterprise Auto ID
User's Manual



Software License Agreement

CAREFULLY READ THE FOLLOWING TERMS AND CONDITIONS BEFORE USING THIS PRODUCT. INSTALLATION INDICATES YOUR ACCEPTANCE OF THESE TERMS AND CONDITIONS. PROMPTLY REMOVE ALL FILES RELATED TO THIS PRODUCT FROM YOUR HOST PLATFORM SHOULD YOU DISAGREE WITH ANY OF THE TERMS OR CONDITIONS LISTED BELOW.

1. "Software" shall mean the digitally encoded, machine-readable data and program. The term "Software Product" includes the Software identified on the distribution media and any accompanying documentation. The term "Distribution Media" refers to any method by which the Software Product is delivered to the end user, including but not limited to Floppy Disks, CD-ROM, Magnetic Tape and On-Line distribution via the Internet. The Software Product is licensed (not sold) to you, and Printronix Auto ID Technology, Inc. either owns or licenses from other vendors who own, all copyright, trade secret, patent and other proprietary rights in the Software Product.
2. You agree to accept a non-exclusive license to use the Software identified on the distribution media solely for your own customary business or personal purposes.
3. To protect the proprietary rights of Printronix Auto ID Technology, Inc., you agree to maintain the Software Product and other proprietary information concerning the Software Product in strict confidence and to establish reasonable procedures regulating access to and use of the software.
4. You agree not to duplicate or copy the Software except that you may make one backup copy. You agree that any such copy shall contain the same proprietary notices as those appearing on the original.
5. You shall not sublicense, sell, lease, or otherwise transfer all or any portion of the Software Product separate from the printer(s), without the prior written consent of Printronix Auto ID Technology, Inc.
6. You may not modify or prepare derivative works of the Software Product. You may not transmit the Software Product over a network, by telephone, or electronically using any means; or reverse engineer, decompile or disassemble the Software.
7. You may transfer the Software Product with the printer(s), but only if the recipient agrees to accept the terms and conditions of this Agreement. Your license is automatically terminated if you transfer the Software Product and printer(s).
8. This License shall continue until terminated. This license may be terminated by agreement between you and Printronix Auto ID Technology, Inc. or by Printronix Auto ID Technology, Inc. if you fail to comply with the terms of this License and such failure is not corrected within thirty (30) days after notice. When this License is terminated, you shall either return to the place you obtained them, or destroy, the printer and all copies of the Software and documentation.
9. Printronix Auto ID Technology, Inc. warrants that for ninety (90) days after delivery, the Software will perform in accordance with specifications published by Printronix Auto ID Technology, Inc., and that the distribution media will be free from defects in material and workmanship. Printronix Auto ID Technology, Inc. does not warrant that the Software is free from all bugs, errors and omissions.

THE PARTIES AGREE THAT ALL OTHER WARRANTIES, EXPRESS OR IMPLIED, INCLUDING WARRANTIES OF FITNESS FOR A PARTICULAR PURPOSE AND MERCHANTABILITY ARE EXCLUDED.

10. Your exclusive remedy and the sole liability of Printronix Auto ID Technology, Inc. in connection with the Software is replacement of defective distribution media upon their return to Printronix Auto ID Technology, Inc. Printronix Auto ID Technology, Inc. will not be liable for any loss or damage caused by delay in furnishing a Software Product or any other performance under this Agreement.

Printronix Auto ID Technology does not warrant that the functions contained in the Software will meet your requirements or that the operation of the Software will be uninterrupted or error free.

Printronix Auto ID Technology reserves the right to make changes and/or improvements in the Software without notice at any time.

IN NO EVENT WILL PRINTRONIX AUTO ID TECHNOLOGY, INC. BE LIABLE FOR LOST PROFITS, LOST DATA, BUSINESS INTERRUPTIONS OR ANY OTHER DIRECT, INDIRECT, INCIDENTAL OR CONSEQUENTIAL DAMAGES ARISING OUT OF THE USE OF OR INABILITY TO USE THIS PRODUCT, EVEN IF PRINTRONIX AUTO ID TECHNOLOGY, INC HAS BEEN ADVISED OF THE POSSIBILITY OF SUCH DAMAGES, OR ANY DAMAGES CAUSED BY ABUSE OR MANIPULATION OF THE SOFTWARE. SOME STATES DO NOT ALLOW THE EXCLUSION OR LIMITATION OF

LIABILITY FOR CONSEQUENTIAL OR INCIDENTAL DAMAGES, SO THE ABOVE LIMITATION MAY NOT APPLY TO YOU.

11. California law governs this Agreement.

12. Use, duplication or disclosure by the Government is subject to restrictions as set forth in the Rights in Technical Data and Computer Software clause at FAR 242.227- 7013, subdivision (b) (3) (ii) or subparagraph (c) (1) (ii), as appropriate. Further use, duplication or disclosure is subject to restrictions applicable to restricted rights software as set forth in FAR 52.227-19 (c) (2).

YOU ACKNOWLEDGE THAT YOU HAVE READ THIS AGREEMENT, UNDERSTAND IT, AND AGREE TO BE BOUND BY ITS TERMS AND CONDITIONS. NEITHER PARTY SHALL BE BOUND BY ANY STATEMENT OR REPRESENTATION NOT CONTAINED IN THIS AGREEMENT. NO CHANGE IN THIS AGREEMENT IS EFFECTIVE UNLESS WRITTEN AND SIGNED BY PROPERLY AUTHORIZED REPRESENTATIVES OF EACH PARTY. BY INSTALLING THIS SOFTWARE PRODUCT, YOU AGREE TO ACCEPT THE TERMS AND-CONDITIONS OF THIS AGREEMENT.

This document contains proprietary information protected by copyright. No part of this document may be reproduced, copied, translated or incorporated in any other material in any form or by any means, whether manual, graphic, electronic, mechanical or otherwise, without the prior written consent of Printronix Auto ID Technology, Inc.

Printronix Auto ID Technology, Inc. makes no representations or warranties of any kind regarding this material, including, but not limited to, implied warranties of merchantability and fitness for a particular purpose. Printronix Auto ID Technology, Inc. shall not be held responsible for errors contained herein or any omissions from this material or for any damages, whether direct, indirect, incidental or consequential, in connection with the furnishing, distribution, performance or use of this material. The information in this manual is subject to change without notice.

Trademark Acknowledgements

Access is a trademark of Microsoft Corporation.

Cisco is a registered trademark of Cisco Systems, Inc. Epson is a registered trademark of Seiko Epson Corporation.

Excel, Microsoft, and Windows are registered trademarks of Microsoft Corporation. J2SE, Java, and Solaris are trademarks of Sun Microsystems, Inc.

LinePrinter Plus, Printronix Auto ID Technology, and PrintNet are registered trademarks of Printronix Auto ID Technology, Inc. Linux is a registered trademark of Linus Torvalds.

Pentium is a registered trademark of Intel Corporation.

Sun Microsystems is a registered trademark of Sun Microsystems, Inc. UNIX is a registered trademark of Unix System Laboratories, Inc.

Copyright © 2016 Printronix Auto ID Technology, Inc. All rights reserved.

Table of Contents

Software License Agreement.....	12
Trademark Acknowledgements	13
1 Overview.....	11
PrintNet Enterprise Auto ID	11
Requirements	11
Installing the Software	11
Printer Setup.....	11
PNE Auto ID Method.....	11
Telnet Method	11
Operator Panel Method.....	12
Set Password	13
Set Telemetry Path (SL5000/T5000 Series Only)	14
Check Port Number	14
Loading and Using Foreign Language Fonts	15
Limitations	15
Windows Setup	15
Unix Setup.....	15
Getting Started	17
2 Printer Database.....	23
Overview.....	23
The Menu Bar	24
The File Menu	24
Preferences.....	25
The Edit Menu.....	34
The View Menu	36
The Status Menu.....	41
The Utilities Menu	52
The Help Menu	53
The Toolbar	54
Managing the Database	56
Defining Printer Properties.....	56
3 Applications and Web Access.....	65
Configuration Editor.....	65
Creating Configurations	66
Changing Configurations	66
Saving Configuration Files	69
Opening Configuration Files	70
Factory Settings Differences	73
Menu Bar.....	74

Toolbar	75
Configuration Settings Differences Views.....	75
Displayed Language	77
Flash File Manager.....	77
Get File Info.....	78
Upload.....	79
Delete And Optimize	80
CST Manager	80
File Download	80
Define the Download Files	80
Download the Files	81
Recovery File	89
GPIO Manager	90
Media Profiler	90
The Menu And Toolbar	91
Capture	92
Profiler View.....	93
The Status Bar	97
For More Information	97
Operator Panel	97
Primary/Secondary Operator Keys	100
Message Display.....	100
Status Indicator	100
Disabled Indicator	100
In Progress Indicator.....	100
Information Capture.....	101
File	101
Configuration Printout	101
Error Log	102
Directory.....	102
AutoID Data Manager.....	104
ODV Quality Wizard	104
Speed Keys	105
Job Capture	106
Job Capture Features	107
Web Access.....	109
The PNE Auto ID Web Site URL Address	110
Login To The PNE Auto ID Web Site.....	110
Changing The User Password.....	111
The Printer List Page	112
Changing User Settings, IP Addresses, and IP Address Ranges	113
4 Utilities.....	117

Reboot Printer	117
Set Printer Password.....	117
Set Wireless Properties.....	118
General Tab	118
WEP Encryption Tab.....	119
Kerberos Tab	120
EAP Tab.....	123
WPA Tab.....	124
Macro Utility	124
Configure Macro	125
SNMP Browser	128
Assign IP Address	129
Enable Remote Printer Management	130
Lock/Unlock Menus	131
Configure Print Servers	132
5 Datastream Adapter.....	133
Overview.....	133
CST Manager	134
The Menu And Toolbar	135
Input/Output Fields.....	138
The CST Listing Field	138
CSTs and CST Bundles.....	139
Status Bar	139
Modes and Attributes.....	139
Modes	139
Additional Features.....	144
The Use Once Flag.....	144
The Entry On/Off Flag.....	145
Edit Information	145
General Tab	145
Memo Tab	145
Patterns / Variables	146
Pattern Character Tab	146
Pattern Tab	148
Formatted Pattern Tab.....	149
How to Use Patterns	152
Pattern Recognition Example	153
Variable Tab.....	161
Status Response Definition.....	162
Conditions	162
Protocols	163
How To Use Conditions And Protocols.....	164

Status Response Generator Example	164
CST Manager And EBCDIC	168
CST Manager Version Control System	176
Application Name and Version Information	176
Viewing File Version Information	178
Automatic File Backup System	178
Backup History	179
6 GPIO Manager.....	181
Introduction	181
Events and Actions	181
The Hardware	182
Overview	183
The Toolbar And Menus	183
Event To Action Mapping	190
Events	191
Actions	200
Event to Action Mapping Buttons	208
Multiple Actions	208
The ON Flag.....	209
The Status Line	209
Data Fields	211
Data Field Actions	211
Data Field Events.....	214
Reports	217
Defining Reports	217
Creating Sections.....	218
Creating Reports.....	220
Using Reports	223
Timers.....	224
Delay Timer Mode.....	224
Daily Timer Mode	225
Weekly Timer Mode	226
Using Timers	227
Mapping	228
Download Mapping Tables	228
Preloaded Table.....	229
Mapping Examples	230
Pin Code Protected Printer	235
GPIO Version Control System.....	240
Application Name and Version Information	240
Viewing File Version Information	242
Automatic File Backup System	242

Backup History	243
Technical Information	244
Opto-couplers.....	244
Relays	244
Voltages	244
I/O Connector.....	245
Basic GPIO Schematic Diagram	246
Electrical Inputs And Outputs	247
GPIO Opto-coupled Input Circuit	247
GPIO Opto-coupled Output Circuit	247
7 AutoID Data Manager	249
Overview.....	249
Data Validation	249
The Menu And Toolbar	250
Printer List.....	251
Report Generation	252_Toc4401521
Report Parameters.....	253
Viewing Telemetry Data.....	254
Telemetry Data Export To 3rd Party Databases	265
Examples Of Property Definitions	266
Example Exporting Telemetry Data To A Microsoft Access Database	267
Exporting Telemetry Data To A Microsoft SQL Database	269
User Fault Generation	270
How To Generate A User Fault.....	270
Data Field Names.....	272
Label Data Fields	272
Bar Code Data Fields.....	273
A Linux Font Configuration File	277
B Contact Information	283

1 *Overview*

PrintNet Enterprise Auto ID

PrintNet Enterprise Auto ID (PNE Auto ID) allows you to organize all of the printers in your office remotely in a single database, download software and printer configuration settings from a host computer with a single mouse click, and use a virtual operator panel to configure printers in the same room or on the other side of the world.

Requirements

- Printronix Auto ID Technology, Inc. thermal printer with PSA3 or PSA4.
- The printer must be attached to the host system via a 10/100Base-T network interface card (NIC) or a wireless NIC; if you do not have a NIC, contact Printronix Auto ID for an upgrade. If available, USB connection may also be used.
- A host computer running the Windows® (XP through Windows 10) or UNIX® (such as Linux® or Solaris™) operating system
- For Windows, a minimum hardware configuration of a 450MHz Pentium® or equivalent, with 128 MB of RAM available

To install and edit the database, it is not necessary to have the printers connected. When starting a session with a printer, the printer must be connected and turned on.

Installing the Software

PNE Auto ID is available via download from the Printronix Auto ID website. Follow the zipped instructions to install PNE Auto ID.

Printer Setup

Your printer uses the diagnostic port to communicate with PNE Auto ID. The diagnostic port must be configured to interact with the NIC. Follow the PNE Auto ID, Telnet, or Operator Panel Method below for your printer model to configure the diagnostic port.

PNE Auto ID Method

All Supported Printers

You can configure the diagnostic port to interact with the NIC using PNE Auto ID. See Enable Remote Printer Management on page 130.

Telnet Method

All Supported Printers

1. Install and enable the NIC (refer to the installation instructions).

2. Make sure the IP Address is set up on the NIC:
 - Use the operator panel (refer to the *Administrator's Manual*).
 - OR –
 - Use PNE Auto ID: select **Utilities** γ **Assign IP Address**. See Assign IP Address on page 129.
3. Open a command prompt session and type:
telnet ipaddress
4. At the telnet login: prompt, type:
root<Enter>
5. At the Password: prompt, enter the password and press <Enter> (there is no password by default)
6. At the ipaddress:root> prompt, type:
enable printermgr<Enter>
7. Close the telnet session. The NIC is now activated.

Operator Panel Method

T8000/T6000/T4000/T800 Series Printers

1. Press **ONLINE** key to enter Offline mode.
2. Press Left or Right key until the Settings icon is highlighted.
3. Press \downarrow to enter Menu mode.
4. Press the UP and Down keys at the same time to unlock the \downarrow key.
5. Press the Left or Right key until the System icon is highlighted.
6. Press \downarrow to enter the SYSTEM menu.
7. Press the Up or Down key until Printer Mgmt is highlighted.
8. Press \downarrow to enter the Printer Mgmt menu.
9. Press the Up or Down key to until PNE Auto ID Port Choice is highlighted.
10. Press \downarrow to change the PNE Auto ID port selection.
11. Press the Up or Down key until Ethernet displays.
12. Press \downarrow to select it. An asterisk (*) displays after Ethernet.
13. Press the UP and Down keys at the same time to lock the \downarrow key.
14. Press the Online key to select how the new setting should be applied.
15. Press the Up or Down key to select whether the setting should be saved permanently or temporary.
16. Press \downarrow to save the setting and place the printer back online.

SL5000r/T5000r Series Thermal Printers

1. On the operator panel, press the **PAUSE** key to take the printer offline.
2. Press \equiv to place the printer in Menu mode. QUICK SETUP displays on the operator panel.
3. Press \downarrow and \leftarrow at the same time to unlock the \downarrow key.
4. Press **+** until PRINTER MGMT displays.
5. Press \downarrow until PNE Auto ID Port displays.







NOTE: If PNE Auto ID Port does not display, see Factory Menu below.

6. If you have the internal PCI NIC, press **+** until Ethernet displays. If you have the external NIC, press **+** until Adapter displays.
7. Press **↵** to select it.
8. Press **↓** and **↵** at the same time to lock the **↵** key.
9. Press **PAUSE** twice to put the printer back online.

Factory Menu

1. On the operator panel, press the **PAUSE** key to take the printer offline.
2. Press **↓** and **↵** at the same time to unlock the **↵** key.
3. Press **+**, **-**, **↓**, and **↑** at the same time to enter the Factory menu.
4. Press **↓** until PNE Auto ID Port (or Diagnostic Port) displays.
5. If you have the internal PCI NIC, press **+** until Ethernet (or Debug Ethernet) displays. If you have the external NIC, press **+** until Adapter (or Debug Adapter) displays.
6. Press **↵** to select it.
7. Press **↓** and **↵** at the same time to lock the **↵** key.
8. Press **PAUSE** twice to put the printer back online.

SL4M/T4M Series Thermal Printers

1. Press  to enter Menu mode.
2. Press the Down and **↵** keys at the same time to unlock the **↵** key.
3. Press the Right key until  PRINTER SETUP displays.
4. Press **↵** to enter the  PRINTER SETUP menu.
5. Press the Up key until Admin User displays.
6. Press the Right key until Enable displays.
7. Press **↵** to select it. An asterisk (*) displays after Enable.
8. Press  to enter Menu mode.  MEDIA SETUP displays.
9. Press the Down key until  INTERFACES displays.
10. Press **↵** to enter the  INTERFACES menu.
11. Press the Down key until Printer Mgmt displays.
12. Press **↵** to enter the Printer Mgmt menu.
13. Press the Down key until PNE Auto ID Port displays.
14. Press the Right key until Ethernet displays.
15. Press **↵** to select it. An asterisk (*) displays after Ethernet.
16. Press the Down and **↵** keys at the same time to lock the **↵** key.
17. Press **||** twice to put the printer back online.

Set Password

See Set Printer Password on page 117 to learn how to set passwords.

If the password is unknown you must clear it first.

SL5000/T5000 Series

Go into the Factory menu (press +, -, ↓, and ↑ at the same time). Press ↑ or ↓ until Clear Password displays. Unlock the ↵ key, then press ↵ to clear the User and Supervisor passwords.

Under the Security tab in Printer Properties, delete any passwords that already exist. Now you may set new passwords as described on page 117.

SL4M/T4M Series

Go into the Factory menu (press the Up, Down, Left, and Right keys at the same time). Press ↑ or ↓ until Clear Password displays. Unlock the ↵ key, then press ↵ to clear the User and Supervisor passwords.

Under the Security tab in Printer Properties, delete any passwords that already exist. Now you may set new passwords as described on page 117.

All Other Printers

Go into the Factory menu, then into the PRINTER MGMT menu.

Press **NEXT** until Clear Password displays. Unlock the ENTER key, then press **ENTER** to clear the User and Supervisor passwords.

Under the Security tab in Printer Properties, delete any passwords that already exist. Now you may set new passwords as described on page 117.

Set Telemetry Path (SL5000/T5000 Series Only)

The following procedure enables you to collect data using the Data Validation application.

1. On the operator panel, press the **PAUSE** key to take the printer offline.
2. Press ☰ to place the printer in Menu mode. QUICK SETUP displays on the operator panel.
3. Press ↓ and ↵ at the same time to unlock the ↵ key.
4. Press + until VALIDATOR displays.
5. Press ↓ until Telemetry Path displays.
6. Press + or – until Network Port displays.
7. Press ↵ to activate it.

NOTE: Since only one port can be used at a time, DEACTIVATING HOST SERIAL displays.

If you later change the setting to Serial Port or Disabled, REACTIVATING HOST SERIAL will display.

8. Press ↓ and ↵ at the same time to lock the ↵ key.
9. Press **PAUSE** twice to put the printer back online.

For more information, refer to the *Online Data Validator User's Manual*.

Check Port Number

Make sure your printer port number has the same setting as the NIC. To check the port number using PNE Auto ID, see page 20.

To check the port number on the printer, see Table 1 to determine the port number menu location for your printer model. The default port number is 3001.

IMPORTANT Do not set the PNE Auto ID Port Number to the same value as the Status Port Number (the default is 3002) or the Mgmt Port Number (the default is 3007).

Table 1 Port Number Menu Location

Printer Model	Menu
SL4M/T4M	INTERFACES ► Printer Mgmt ► PNE Auto ID Port Number
SL5000r/T5000r	PRINTER MGMT or Factory ► PNE Auto ID Port Number
P8000 P7000	PRINTER MGMT ► PNE Auto ID Port Number

Loading and Using Foreign Language Fonts

PNE Auto ID supports Asian languages such as Korean, Simplified Chinese, and Traditional Chinese. UTF-8 encoding is utilized since it has the ability to support all known languages and is backwards compatible with ASCII (specifically 0 - 7F).

Microsoft operating systems provide most of fonts for the world languages which can be obtained from Microsoft's web site. UNIX operating systems such as Linux and Solaris requires more setup since the operating systems provide less fonts than Microsoft. Java uses five logical fonts (Dialog, Dialoginput, Serif, Sanserif and Monospaced) to map to the fonts on the system. Mapping is done in the Java font.properties file. Dialog, size 12 is the default font for all language dependent applications. Through mapping of the font.properties file, the Dialog font supports all of the printer supported languages. Mapping of operating system fonts should be performed by a System Administrator.

Limitations

Not all of the items in the PNE Auto ID Suite will display UTF-8. All PNE Auto ID menus, dialogs, tooltips and printer names will be displayed in ASCII.

Only the following applications, utilities, and displays support UTF-8 encoding:

- Printer Database status messages
- Printer configuration languages in the Configuration Editor
- Information Capture's viewable configuration data
- Virtual Operator Panel text
- Factory Settings Differences table data
- Web page support (Printer List Page Message area only)
- SNMP Browser data

Older versions of PNE Auto ID Suite (including previous products such as Advanced Tool Kit, ODV Data Manager and EPC Data Manager) will not support new printers with UTF-8 encoded byte streams.

All versions of PNE Auto ID Suite that support UTF-8 encoding will support older printer firmware versions.

Windows Setup

Java for Windows platforms includes a font.properties file that is used to map foreign languages to Microsoft Window fonts. This includes all languages supported on the printer.

Unix Setup

Java for Linux platforms also includes a font.properties file. This file needs to be modified to support the fonts on the user's Linux or Solaris platforms.

Find or purchase the printer supported fonts for the languages needed. The additional printer languages supported include Korean, Simplified Chinese, and Traditional Chinese. Use a package manager such as Red-Hat Package Manager (RPM) to load the font files onto the UNIX system. Once the fonts are loaded, modify the component font mappings in the font.properties file for Allfonts, Serif, Sansserif, Monospaced, Dialog and Dialoginput Logical fonts. Use absolute path names, path names starting with \$JRE_LIB_FONTS or X Logical Font Description (xlfid) names for the fonts.

Add the following:

- new font names to the search sequences
- any exclusion character ranges for the languages
- the paths to the locations of the actual font files.

Finally, add the valid X11 font directories to the X11 server font path. For a detailed description of the font.properties file see Sun's Java Internationalization Guide at <http://java.sun.com/j2se/1.5.0/docs/guide/intl/fontconfig.html>.

See Appendix A for an example of a font.properties file for Asian languages on a Linux OS.

Getting Started

This section provides a short tutorial on how to set up and access a printer using PNE Auto ID.

1. This tutorial assumes the host computer running PNE Auto ID and the printer you want to access are connected by a network. You must know the printer's IP Address and Port Number.
2. From your operating system, launch PNE Auto ID. Click the splash screen to see the main window of the printer database more clearly. See Figure 1.

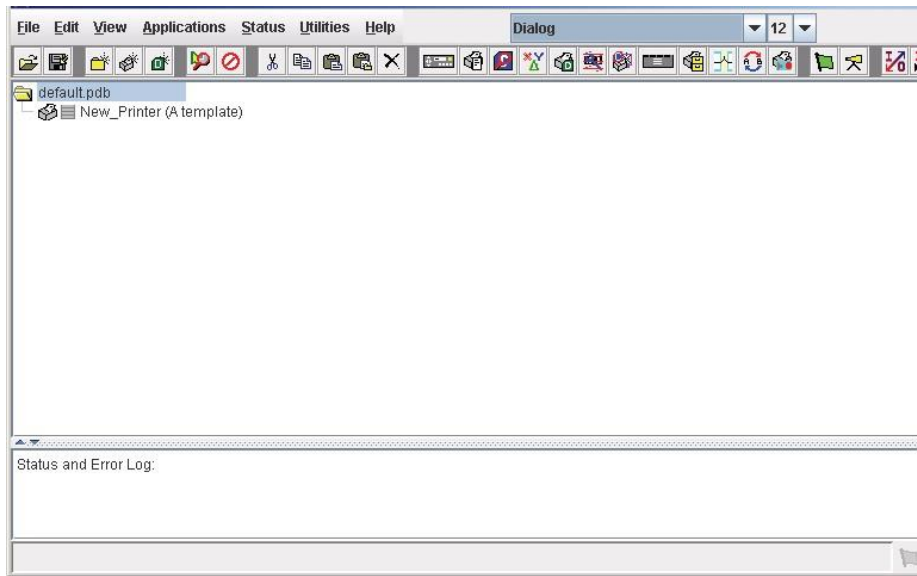

Figure 1 Printer Database Main Window

3. If your printer has USB connected to the PC, you will see the USB printer device. USB Support must be enabled in the PNE under File ► Preferences, and PNE Port Choice must be set to USB in the printer under System ► Printer Mgmt. See Figure 2.

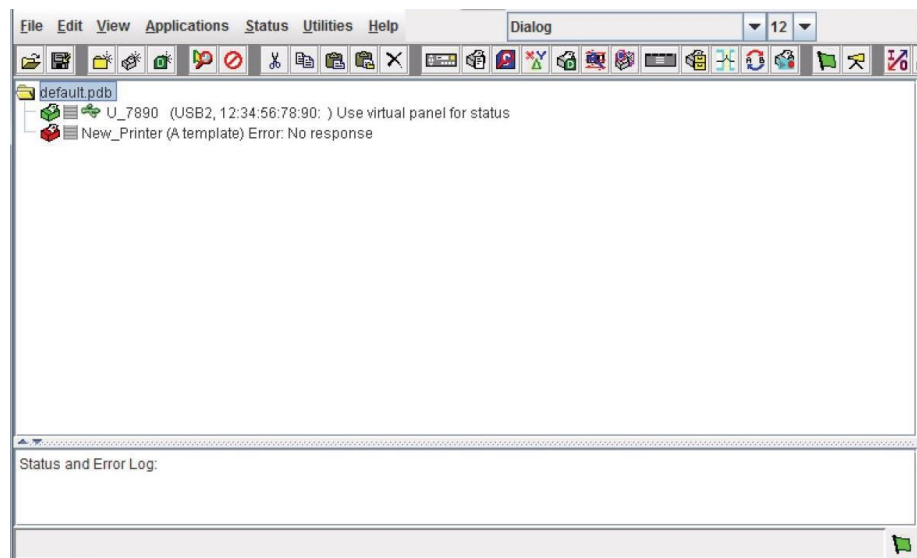

Figure 2 Printer Database Main Window with USB Connection



Figure 3 Printer Properties: Identification Tab

4. Double-click **New_Printer (A template)**. The Printer Properties dialog box opens. See Figure 3.
5. Assign a name to your printer. Delete the words **New_Printer** in the Name (Unique) field, and then type **Tutorial**.
6. Assign a description to this printer. Delete the words **A template** in the Printer Description field, and then type **My First Connection**.



Figure 4 Printer Properties: Security Tab

7. Click the **Security** tab. See Figure 4.
8. If you are using PNE Auto ID for the first time, it is likely that no passwords are assigned to this printer. If you are unsure, contact your system administrator.
 - If no passwords are assigned, leave the password boxes empty.
 - If a User password is necessary to access this printer, type the password in the User Password field.
 - If a Supervisor password is necessary to access this printer, type the password in the Supervisor Password field, and check the Supervisor Mode check box.
 - If a Telnet guest password is necessary to poll the status of the printer, type the password in the Telnet Guest Password field. See Security Tab on page 58.
 - If a Telnet root password is necessary to update wireless printer settings, type the password in the Telnet Root Password field. See Security Tab on page 58.

In any case, an asterisk (*) character appears in the field after each letter you type to preserve password secrecy.

For more details on setting up and changing passwords, see page 52.

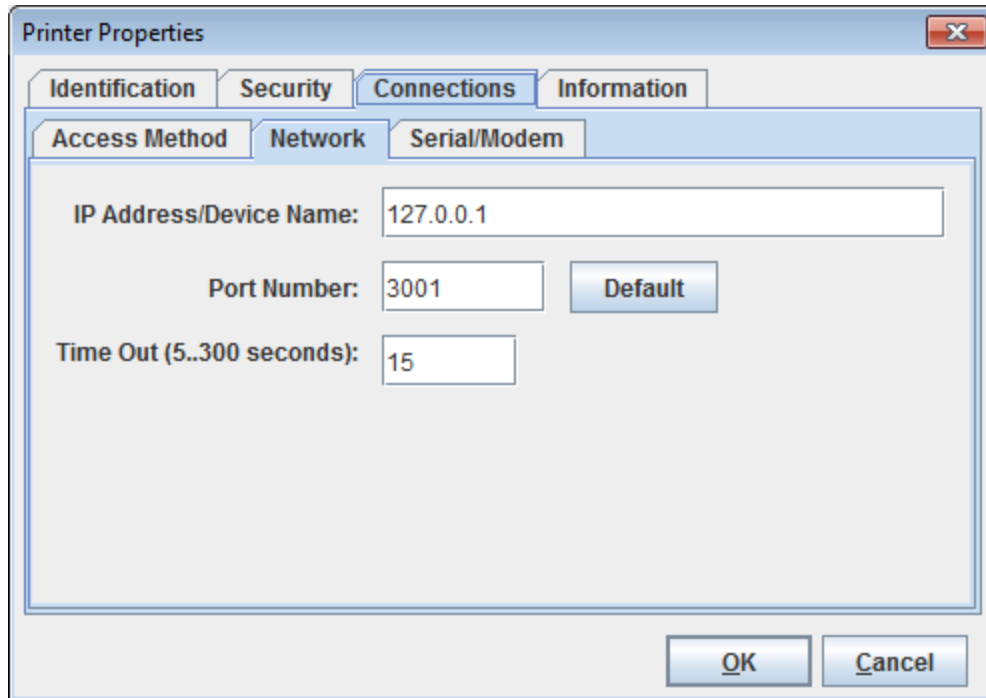

Figure 5 Printer Properties: Connections Tab – Network Sub-Tab

9. Click the **Connections** tab. By default, the Network sub-tab displays.
10. Click the **IP Address/Device Name** field and then type the IP Address or host name of the printer you want to access. Follow the format shown in Figure 5.

The Port Number field must be set to the same port as the printer. Leave it set at 3001. Leave the Time Out (5..300 seconds) field set at 15 seconds.

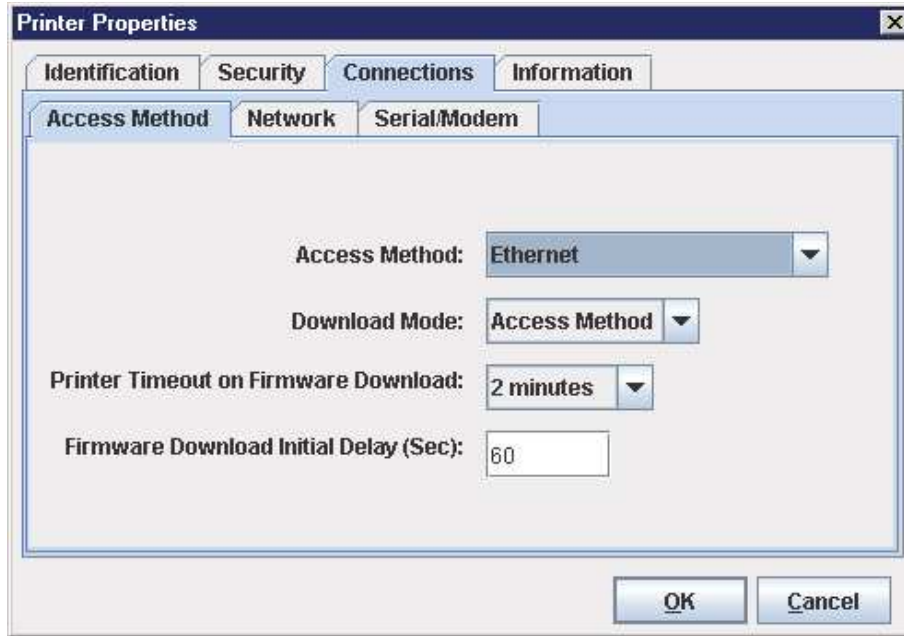

Figure 6 Connections: Connections Tab – Access Method Sub-Tab

11. Click the **Access Method** sub-tab. See Figure 6.

The Access Method tells PNE Auto ID how the host computer communicates with the printer. Make sure it is set to Ethernet. Ignore Download Mode and Download Timeout for now. These options are described in Access Method Sub-Tab on page 61.

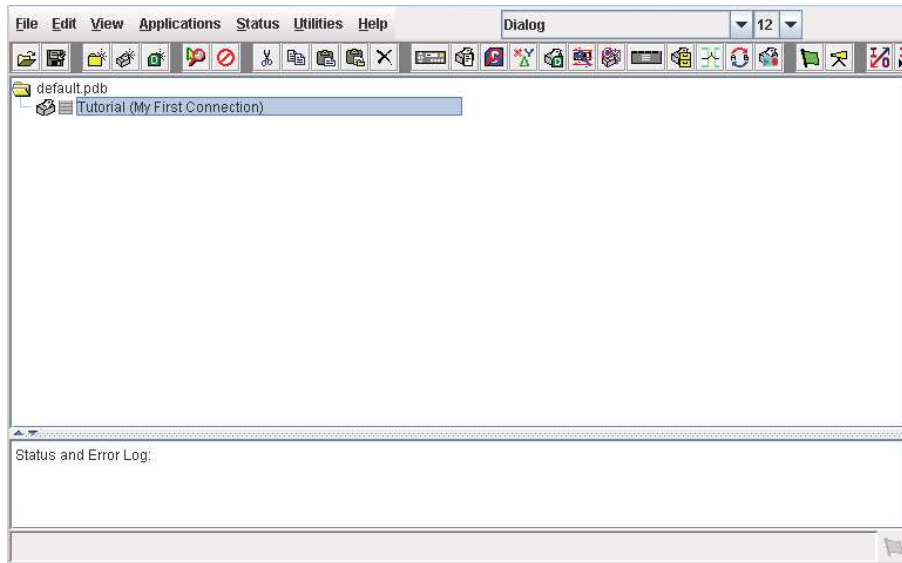

Figure 7 Printer Database Main Window

12. Click **OK**. The Printer Properties dialog box closes and you return to the printer database main window. See Figure 7. Your printer is now set up in the PNE Auto ID database.
13. Try to access the virtual operator panel as a test to see if the information you input is accurate. Follow this procedure:
 - a. **Tutorial (My First Connection)** should be highlighted in blue, as shown in Figure 7. If it is not highlighted, click it to select it.
 - b. Select **Applications ► Operator Panel**. The virtual operator panel appears (see Operator Panel on page 97). If not, an error message appears in the Status and Error Log pane. Check your password to make sure it is correct. If the error continues, contact your system administrator.
 - c. Printers connected via the USB interface are automatically detected by PrintNet Enterprise. The USB interface cannot be manually selected using the Access Method mentioned above. To ensure that a USB connected printer is detected, the printer must have the PNE Auto ID Port set to USB. Make sure that USB Support is enabled under PNE Auto ID Preference. Refer to the Printer Setup section (page 11) for instructions on setting the PNE Auto ID Port.
PNE Auto ID will search for USB connected printers every minute when the application is running.

IMPORTANT Before starting PNE Auto ID, make sure the printer is connected via USB and the PNE Auto ID Port setting is correct. Otherwise, the application may not find the printer.

All USB connected printers that were detected is listed at the top of the printer tree.

2 *Printer Database*

Overview

When you start PNE Auto ID, the printer database window appears first. The printer database tool organizes and controls printers and Download files. Figure 8 shows how the database looks when PNE Auto ID launches for the first time.

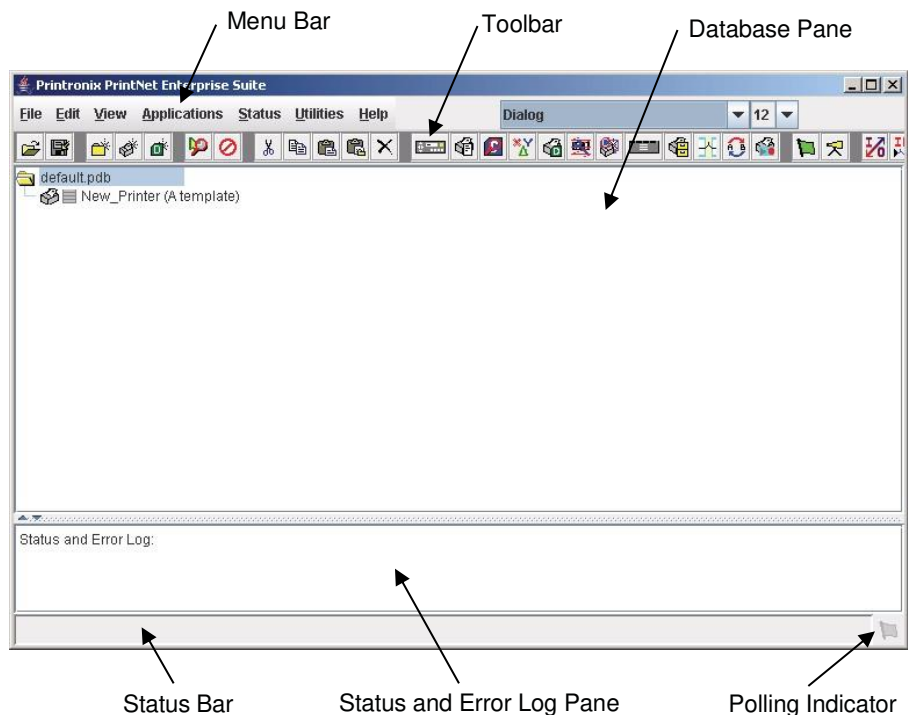

Figure 8 Printer Database Main Window

The menu bar contains all the menus used to control the functions of the program. The menus are described later in this chapter.

The toolbar contains buttons for the most commonly used menu functions. See page 54 for descriptions of the toolbar buttons.

Use the Database pane to access and control your printers in a tree format. The first line of the database tree displays the database file name. In Figure 8, the default file name for this database is **default.pdb**. From there, your database tree branches out to include printers, folders, and Download files, which you can organize into groups. With a single mouse click, you can download a file to several printers at once. In addition, you can use as many databases with PNE Auto ID as you want. Databases save as **.pdb** files on your local hard drive.

NOTE: You can open only one printer database at a time.

The Status and Error Log scrolls status and error messages as you work through the program. If PNE Auto ID does not function properly, look at this pane for error messages. Use the scroll bar on the side of

the pane to reference previous status and error messages. The status and error messages relate to the current PNE Auto ID session, not to the specific database. When you exit PNE Auto ID, these messages will be deleted.

The Status Bar displays brief status messages of PNE Auto ID, some of which appear in the Status and Error Log.

The Polling Indicator turns green whenever printers are being polled.

The Menu Bar

The printer database menu bar is located at the top of the window (see Figure 8). Use the menu bar to access all the functions of PNE Auto ID.

The following are descriptions of the options located on the menu bar.

The File Menu

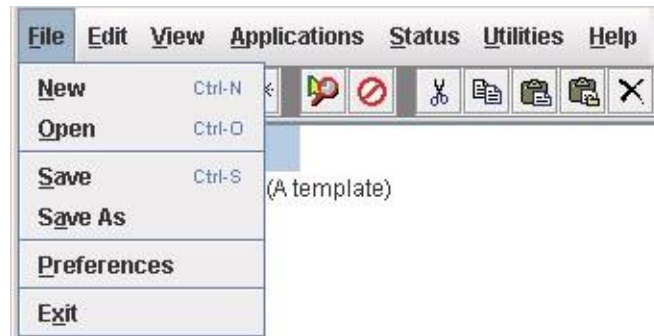

Figure 9 File Menu

New

Creates a new database file. Since PNE Auto ID allows only one database file to be open at a time, it asks if you want to save your changes to the current database before it creates a new one.

Open

Opens a database file. Since PNE Auto ID allows only one database file to be open at a time, it asks if you want to save your changes to the current database before it opens a different one.

Save

Saves the active database file using its current name.

Save As

Prompts you to enter a name for the current database file before PNE Auto ID saves it. Use Save As if you do not want to overwrite the current database file.

Preferences

Opens the Preferences dialog box. See page 25.

Exit

Exits PNE Auto ID.

Preferences

The Preferences dialog box has three tabs: Printer Database, Configuration Editor, and Servers. See Figure 10.

Printer Database Tab

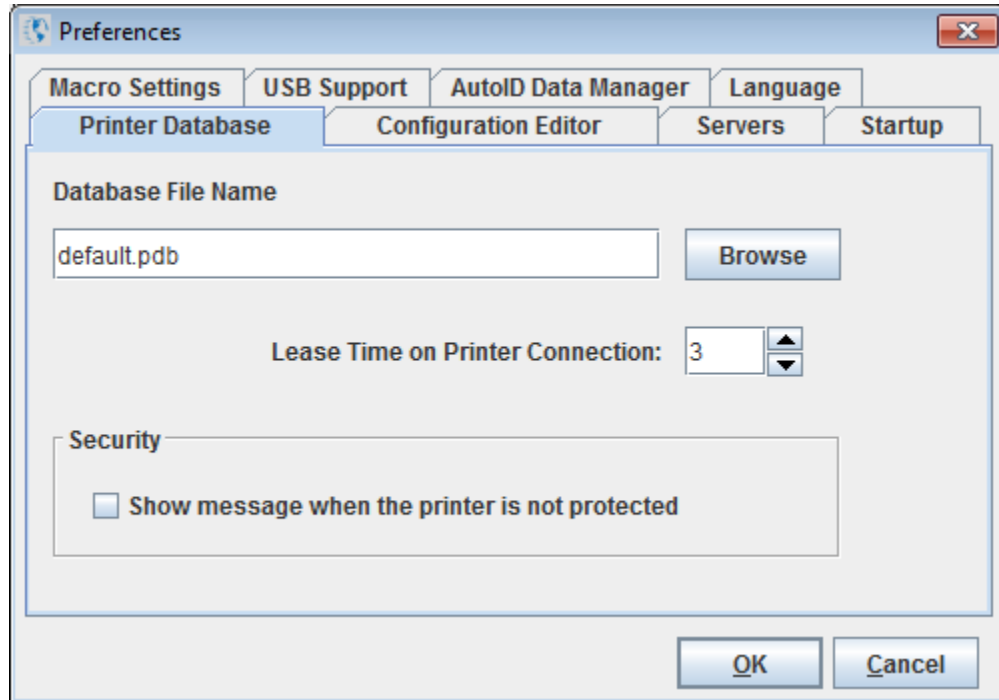

Figure 10 Preferences: Printer Database Tab

The Printer Database tab controls database features.

Database File Name: Enter the name of the default database file. PNE Auto ID opens this database file when the program starts. To select a new default database file, type it into the Database File Name field, or click **Browse** to locate a file on your network.

Lease Time on Printer Connection: Enter an amount (in seconds) to set the maximum amount of time a printer connection can remain open without any communication. The default is three seconds.

Security: Check the **Show message when the printer is not protected** check box to enable a warning message that informs you when a selected printer does not have an assigned password.

Configuration Editor Tab

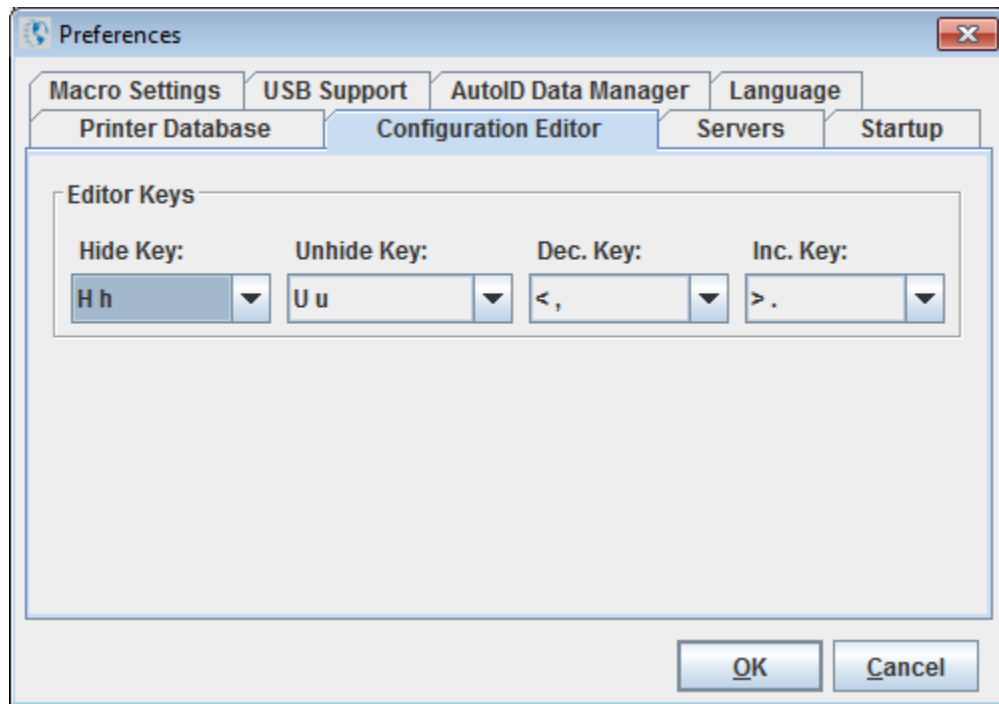

Figure 11 Preferences: Configuration Editor Tab

The Configuration Editor tab controls features of the Configuration Editor utility.

Hide Key/Unhide Key: Assigns which keys hide and unhide menu items in the Configuration Editor menu tree (see page 65). The default for Hide is H h. The default for Unhide is U u.

Dec./Inc. Key: Assigns which keys will decrement and increment menu items in the Configuration Editor menu tree (see page 65). The default for decrement is < ,. The default for increment is > ..

Servers Tab

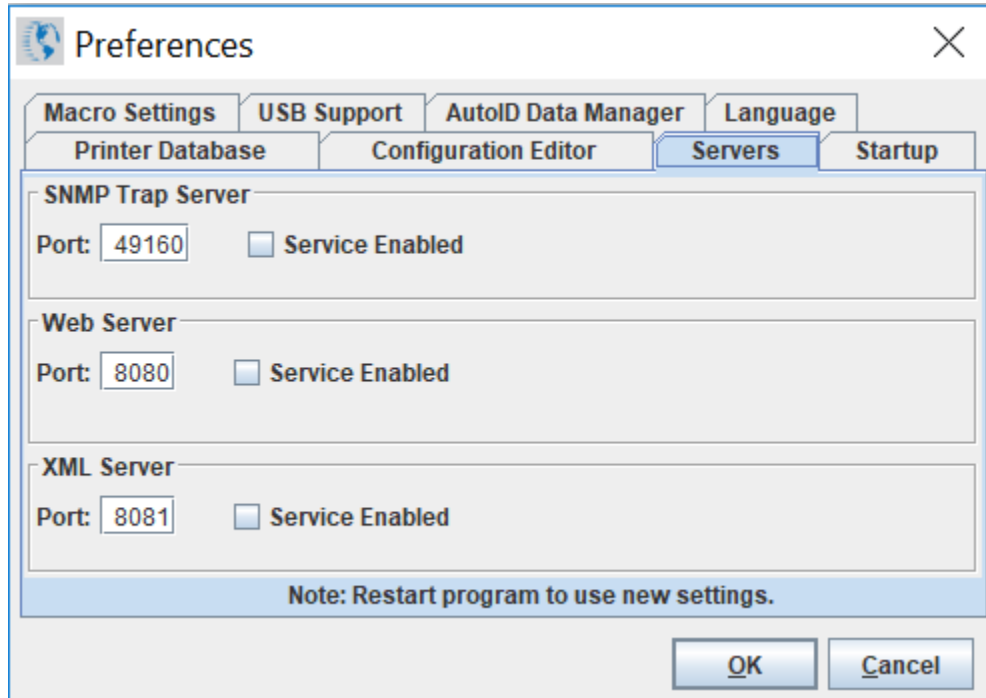

Figure 12 Preferences: Servers Tab

The Servers tab allows you to assign port values for the SNMP (Simple Network Management Protocol) Trap Server, the Web Server, and the XML Server. Click **Service Enabled** next to the corresponding server to turn it on.

NOTE: You must restart PNE Auto ID to use the new settings and enable the servers.

SNMP Trap Server: The service that enables PNE Auto ID to receive alerts from the printer when its status changes. Once PNE Auto ID receives the alert, PNE Auto ID creates an instant status poll to reflect the change in the database pane. For instance, if you turn the printer offline, the printer sends an alert to PNE Auto ID causing it to change the printer status instantly. In the database pane, the printer status changes to offline.

NOTE: The SNMP Trap Server works only if the printer's NIC is configured correctly using the Configure Print Servers utility. See Configure Print Servers on page 132.

Web Server: Allows you to view the active PNE Auto ID using a web browser. See Web Access on page 109.

NOTE: If you want to use the Web Server service, you must also enable the XML Server service.

XML Server: PNE Auto ID uses XML to communicate with its web server.

Startup Tab

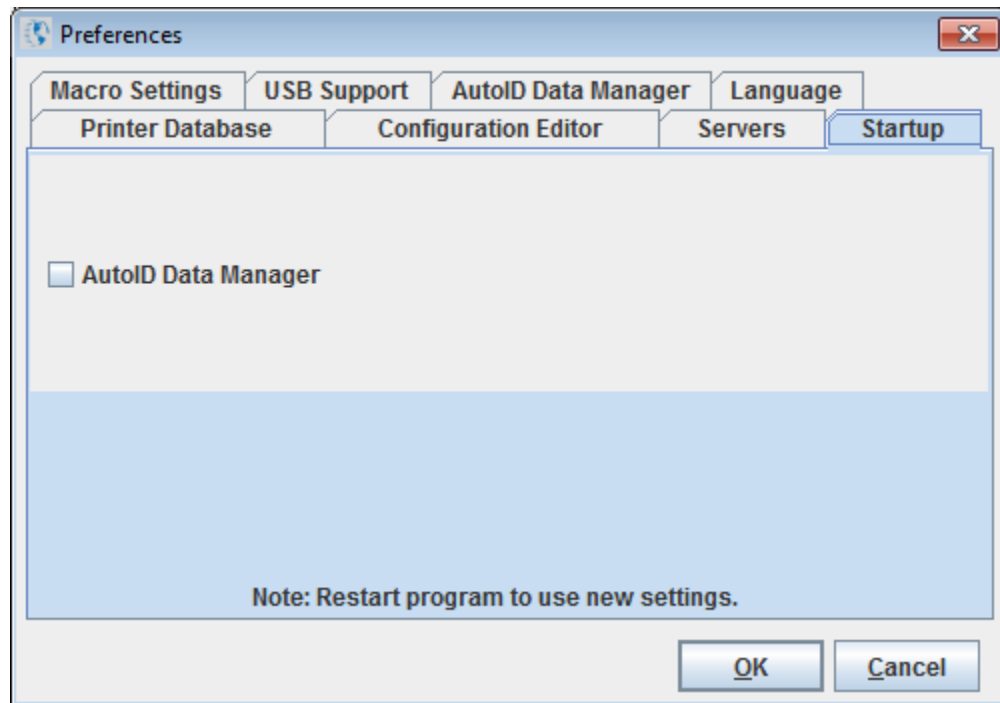

Figure 13 Preferences: Startup Tab

In the Startup tab, check the AutoID Data Manager check box to set the AutoID Data Manager (page 249) to launch automatically when PNE Auto ID launches.

If you have added printers in the printer list (page 251), and the Run box is checked, the AutoID Data Manager will launch and begin collecting telemetry data automatically when PNE Auto ID launches.

NOTE: You must restart PNE Auto ID to use the new settings.

Macro Settings Tab

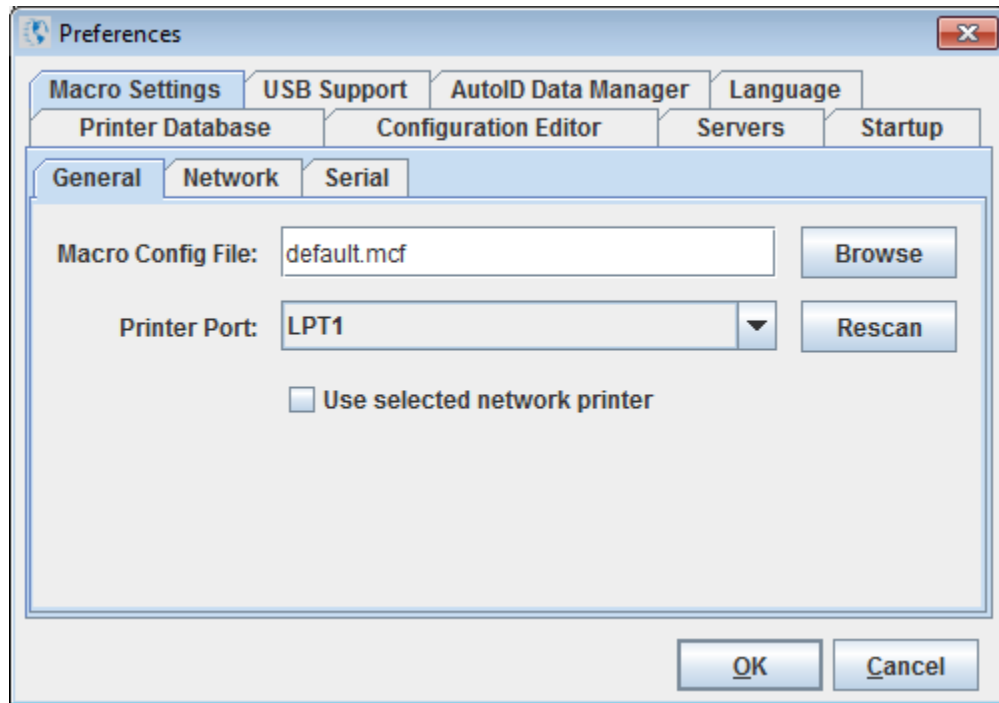

Figure 14 Preferences: Macro Settings Tab – General Sub-Tab

The Macro Settings tab has three sub-tabs: General, Network, and Serial. See Figure 14.

General Sub-Tab

Macro Config File: Displays the macro file that will load automatically when you start the macro utility. To select a new default macro config file, type it into the Macro Config File field, or click **Browse** to locate a file on your network.

Printer Port: Allows you to select the port that data is sent through. The choices vary according to the host computer. Possible choices include LPT1, LPT2, COM1, COM2, and Network.

If you select COM1 or COM2, click the **Serial** tab to further define printer parameters. If you select Network, click the **Network** tab to further define the network parameters.

- **Use selected network printer:** Check this box to send data directly to the network printer selected in the printer database. You do not need to further define network parameters.
- **Rescan:** Checks to see which ports are currently available on the host computer.

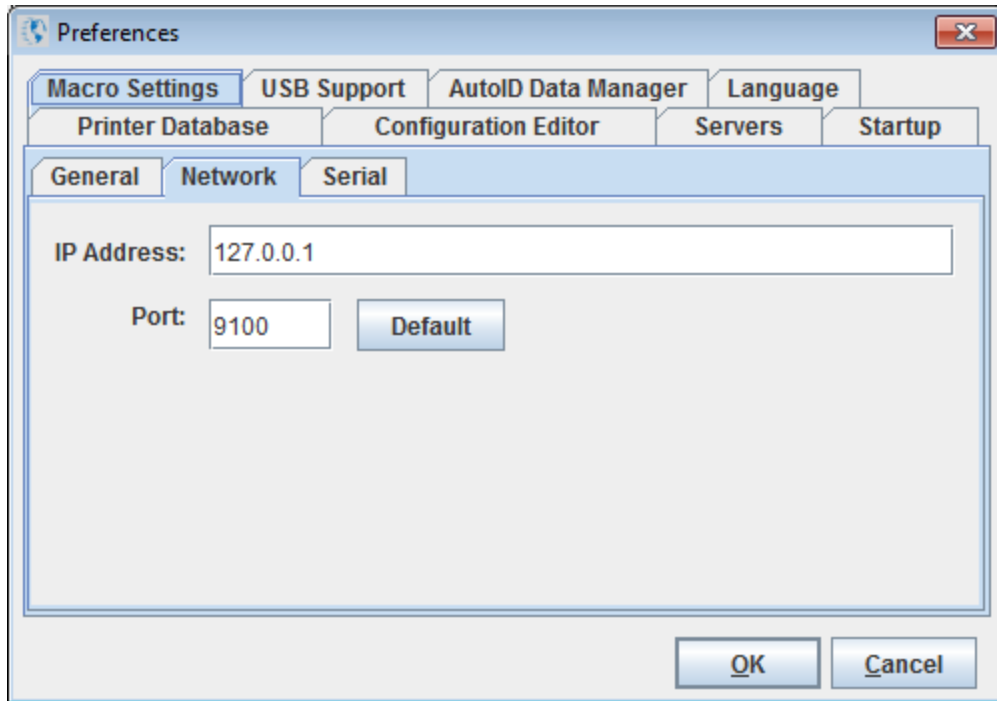

Figure 15 Preferences: Macro Settings Tab – Network Sub-Tab

Network Sub-Tab

Use the Network tab only when the Printer Port on the General tab is set to Network.

IP Address: The address of the printer where PNE Auto ID will send the data.

Port: The port number that PNE Auto ID will use to send the data. This must match the network interface card (NIC) of the printer where PNE Auto ID will send the data. In most cases this is 9100, the default. If not, contact your system administrator.

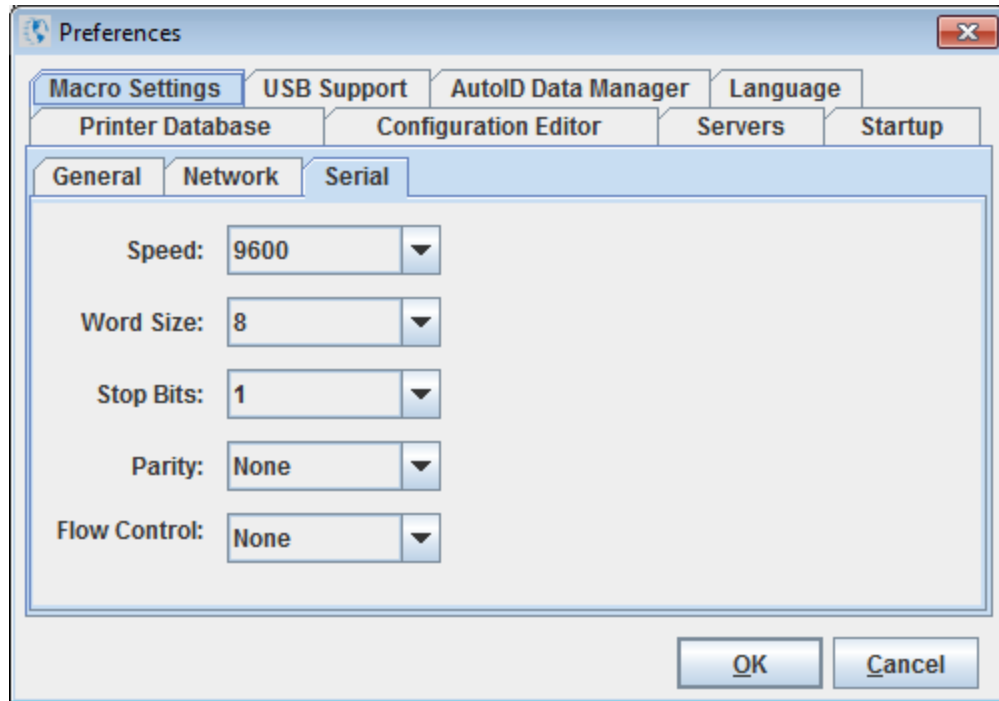

Figure 16 Preferences: macro Settings Tab – Serial Sub-Tab

Serial Sub-Tab

Speed: The baud rate at which data transfers. This setting must match the speed of the printer host serial port under the SERIAL PORT menu (thermal printers) or the SERIAL submenu in the HOST INTERFACE menu (all other printer models). See “Serial Port” (thermal) or “Host Interface” (all others) in your *Administrator’s Manual*.

Word Size: The number of data bits per character. In most cases this should be set to 8.

Stop Bits: Inter-character gap. Can be set to 1 or 2. The normal setting is 1.

Parity: Adds an error checking bit if set to Odd or Even. The default is None. Other settings include Mark and Space.

Flow Control: Prevents data overrun by adjusting the sending side according to the needs of the receiving side.

- **None:** No adjustment occurs.
- **Rts/Cts in:** Hardware flow control on serial-input.
- **Rts/Cts out:** Hardware flow control on serial-output.
- **Xon/Xoff in:** Software flow control on serial-input using the X-on and X-off control characters.
- **Xon/Xoff out:** Software flow control on serial-output using the X-on and X-off control characters.

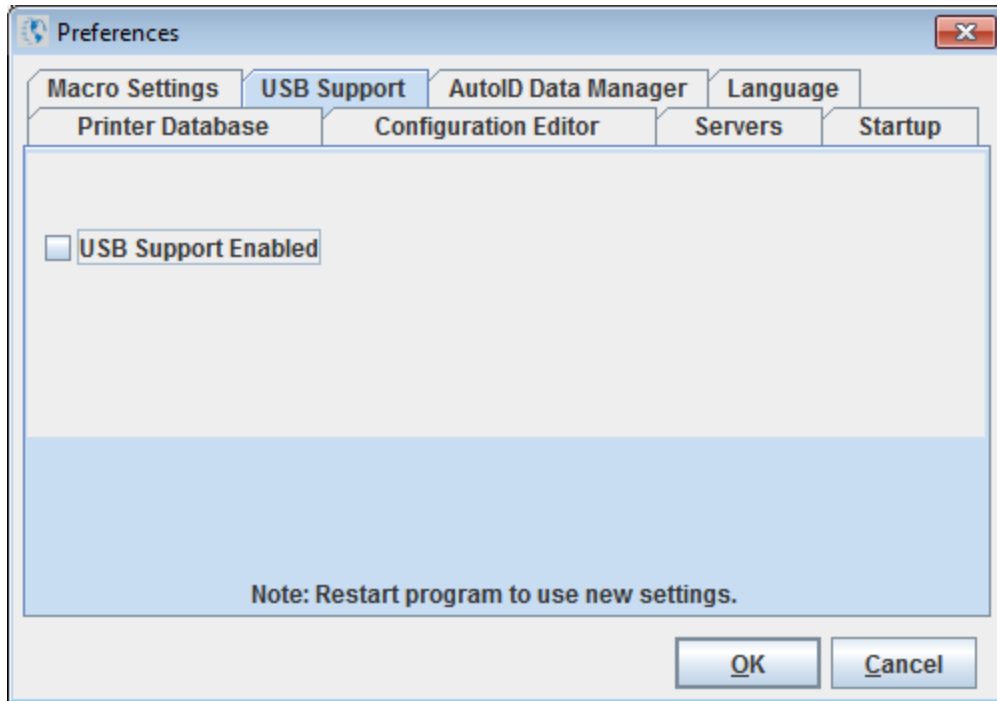
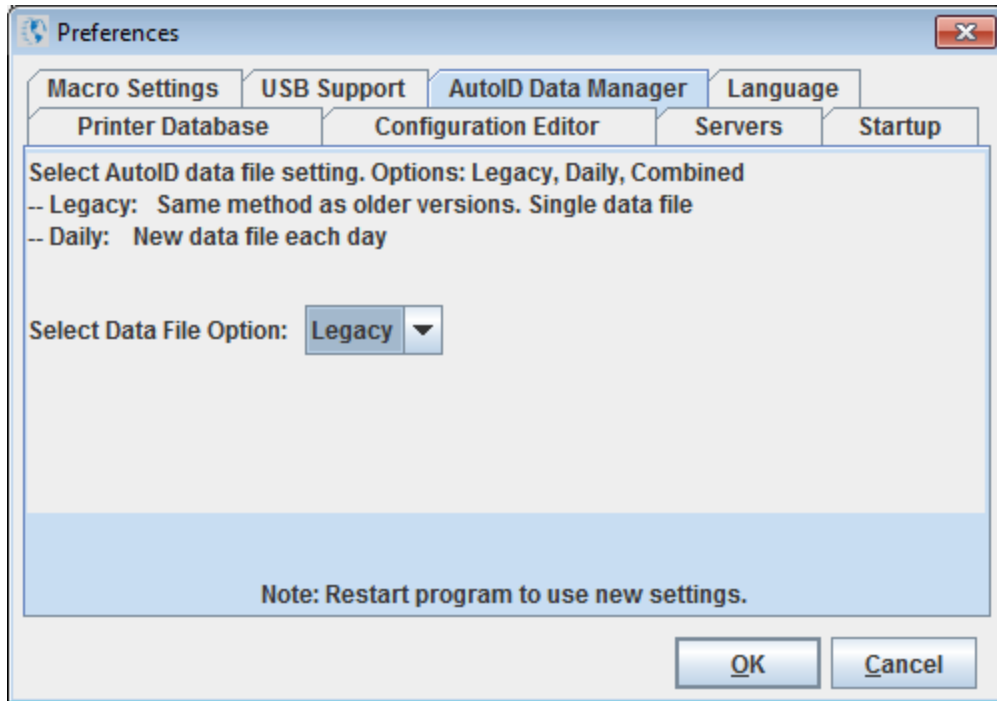

Figure 17 Preferences: USB Support Tab

USB support is disabled by default. It can be enabled by using the Preference setting under the File menu. In the Preference dialog, click the USB Support tab and make sure that the box "USB Support Enable" is checkmarked.

IMPORTANT Restart PNE Auto ID to enable the new USB setting.



New Figure Preferences: AutoID Data Manager Tab

Determines how data files are saved in AutoID Data Manager.

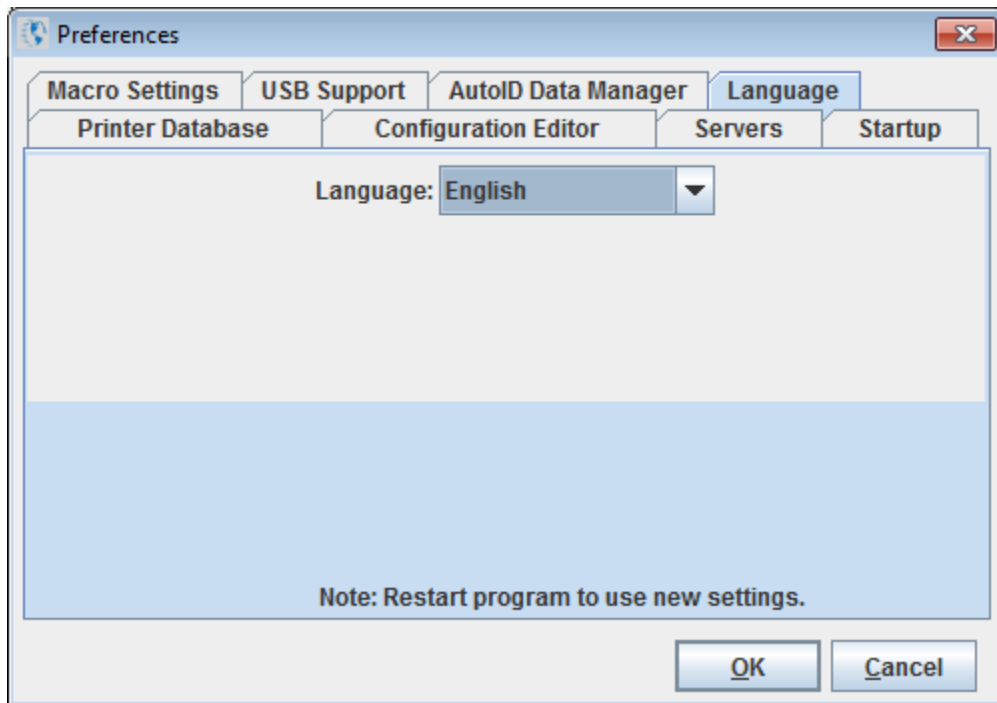

New Figure Preferences: Language

Determines the displayed language between English and Chinese (Simplified).

The Edit Menu

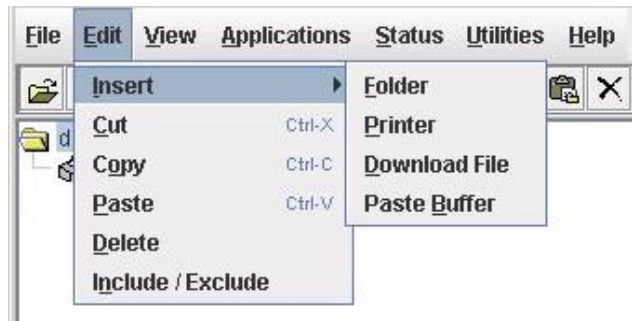





Figure 18 Edit Menu

Use the Edit option on the menu bar to build your database. The options in the Edit menu are described below.

Insert

Adds a folder, printer, or Download file into your database. You must select an existing database item to create a folder, printer, or file. You can also paste the contents of the paste buffer (the last item that was copied or cut) into the database. The new icon appears one level below the selected database item. If there are items below the selected database item, the new item appears at the end.

Inserting an item involves three steps:

1. Select a database item. (The new icon will appear below the item you select.)
2. Define which type of icon you want to add. Select **Edit** ▾ **Insert** ▾ and then select the item you want to add. Or click the  (insert new folder),  (insert new printer), or  (insert new Download file) icon.
A new icon appears in the database.
3. Define what printer, folder, or file this icon represents.
 - a. To define a printer, see Defining Printer Properties on page 56.
 - b. To define a folder, double-click **New Folder**. The Folder Name dialog box opens. Type the name of the folder and click **OK**.
 - c. To define a Download file, see File Download on page 80.

Cut

Removes selected folders, printers, or files from the database and places it in the paste buffer.

Copy

Copies selected folders, printers, or files from the database to the paste buffer, leaving the original intact.

NOTE: You can select multiple database items by using the **Ctrl** or **Shift** key.

Paste

Places the item in the paste buffer on the database tree. To paste, you must select a database item. The pasted item appears on the same level as the selected database item.

NOTE: If you select **Edit** ∟ **Paste**, the pasted item appears on the same level as the selected database item. However, if you select **Edit** ∟ **Insert** ∟ **Paste Buffer**, the pasted item appears one level below the selected database item.

Delete

Permanently removes a selected folder, printer, or file from the database.

Include/Exclude

Deactivates a selected folder, printer, or file. Inactive database items display a red circle with a slash through it on top of the item's icon.

You cannot send information to or receive information from excluded database items using the following Applications, Status, and Utilities menu options: Flash File Manager, File Download, Update Status, and Configure Print Servers.

To activate a database item, select the inactive item and then select

Edit ∟ **Include/Exclude**.

The View Menu

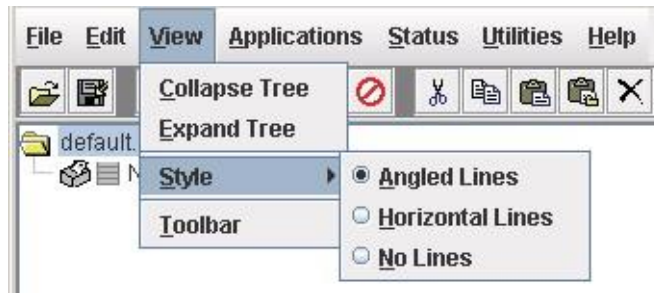

Figure 19 View Menu

Collapse Tree

Collapses all folders on the database menu tree. Only the top level menu items display.

Expand Tree

Expands all folders and printers on the database menu tree. All folders, printers, and Download files display.

Style

Angled Lines: Shows the links between database items using angled lines.

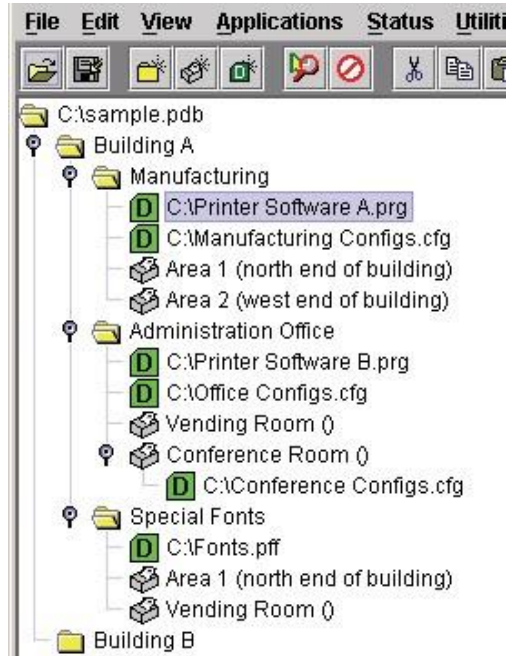

Figure 20 Angled Lines

Horizontal Lines: Shows the links between folders using horizontal lines.

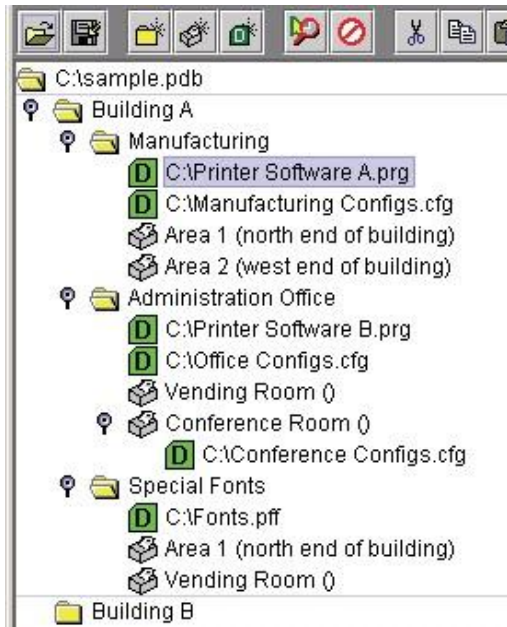

Figure 21 Horizontal Lines

No Lines: Shows no lines between database items.

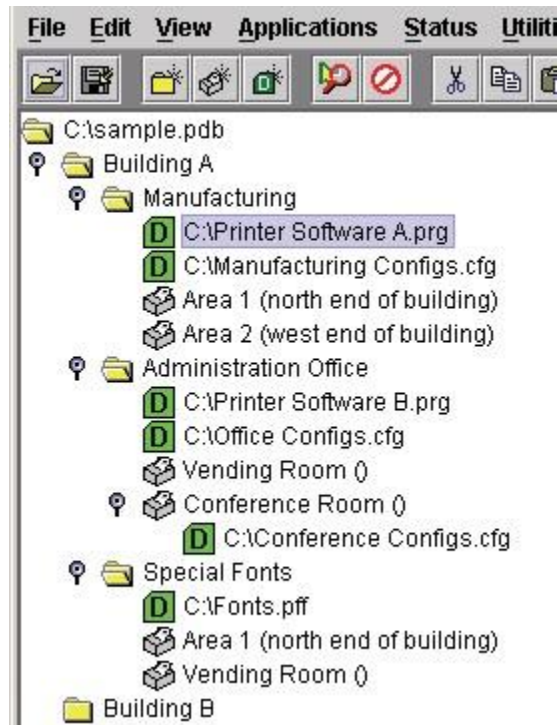

Figure 22 No Lines

Toolbar

Allows you to select which buttons display on the toolbar.

NOTE: By default, some icons do not appear in the toolbar.

For a description of the toolbar icons, see The Toolbar on page 54.

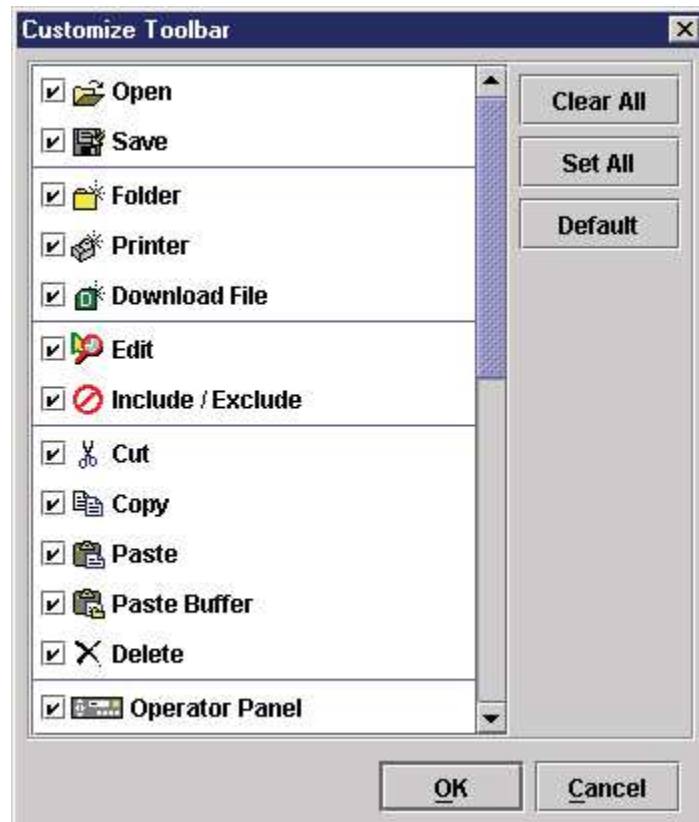

Figure 23 Customize Toolbar

The Applications Menu

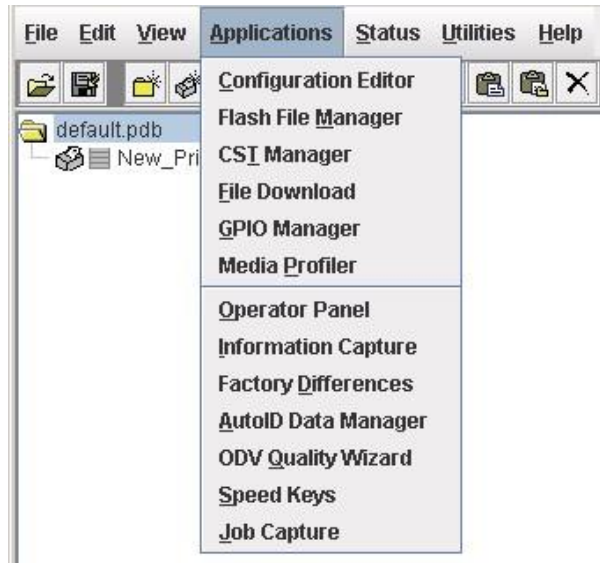

Figure 24 Applications Menu

For an explanation of the Applications menu options, find the menu option in Table 2 and go to the corresponding page.

Table 2 Applications Menu Options

Menu Option	Page
Configuration Editor	page 65
Flash File Manager	page 77
CST Manager	page 134
File Download	page 80
GPIO Manager	page 181
Media Profiler	page 90
Operator Panel	page 97
Information Capture	page 101
Factory Differences	page 73
AutoID Data Manager	page 249
ODV Quality Wizard	page 104
Speed Keys	page 105
Job Capture	page 106

The Status Menu

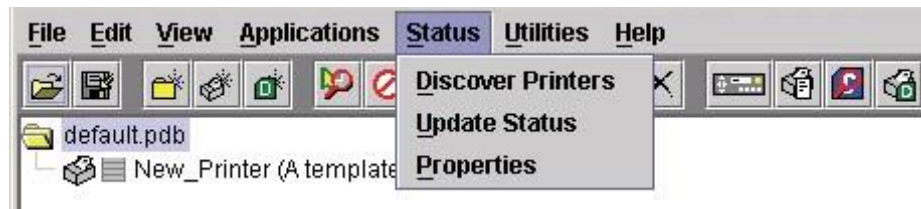



Figure 25 Status Menu

Discover Printers

To search for printers on a network, select **Status** > **Discover Printers**, or click the  **Discover Printers** button at the far right of the toolbar. The results of the search display in the database pane.

Discover Printers searches for printers on a network based on the settings specified in the Discovery tab of the Status Monitoring Properties dialog box. The next section explains how to configure your search.

Properties

Select **Status** > **Properties** to open the Status Monitoring Properties dialog box. The dialog box contains three tabs: Discovery, Polling, and Alert Delivery.

NOTE: To enable printer discovery, check the **Enable Printer Discovery** check box.

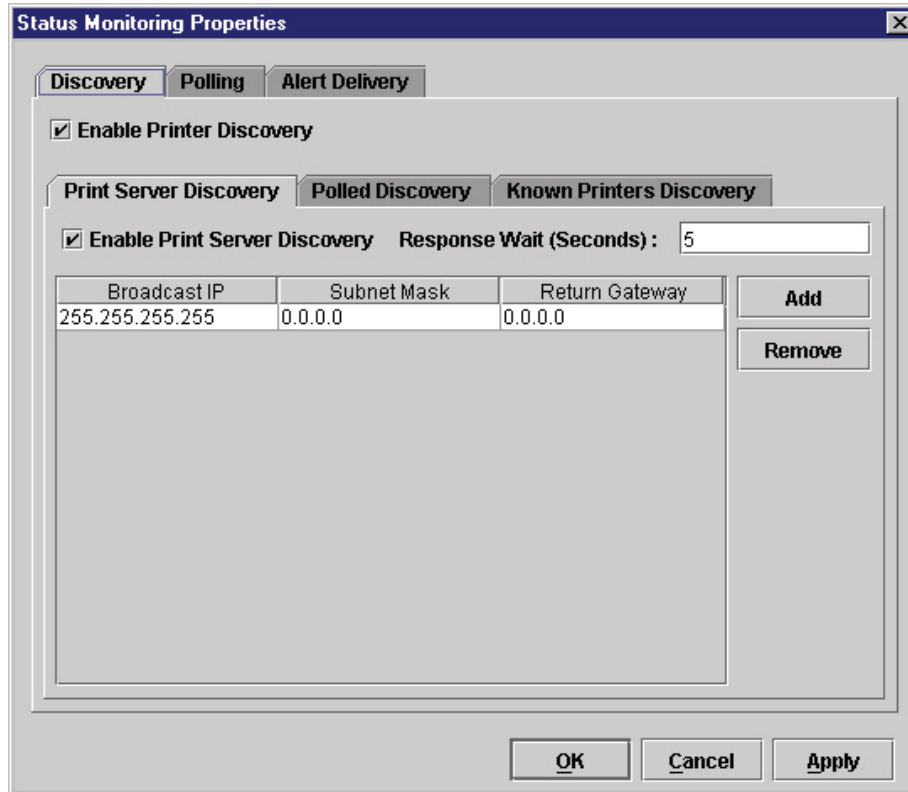

Figure 26 Status Monitoring Properties: Discovery Tab – Print Server Discovery Sub-Tab

Discovery Tab

You can discover printers on a network in three ways:

1. **Print Server Discovery:** This option allows you to discover all PrintNet® printers on a subnet. To enable the option, check the **Enable Print Server Discovery** check box in the Status Monitoring Properties dialog box (see Figure 26), then click **Apply** or **OK**.

Response Wait (Seconds): To specify the time delay (in seconds) PNE Auto ID waits for a printer response. By default, the value is set at 5 seconds.

Broadcast IP, Subnet Mask, and Return Gateway: These settings must match your network configuration. See your system administrator.

NOTE: To discover unconfigured NICs, you must enter the Gateway Address and Subnet Mask in the Return Gateway field.

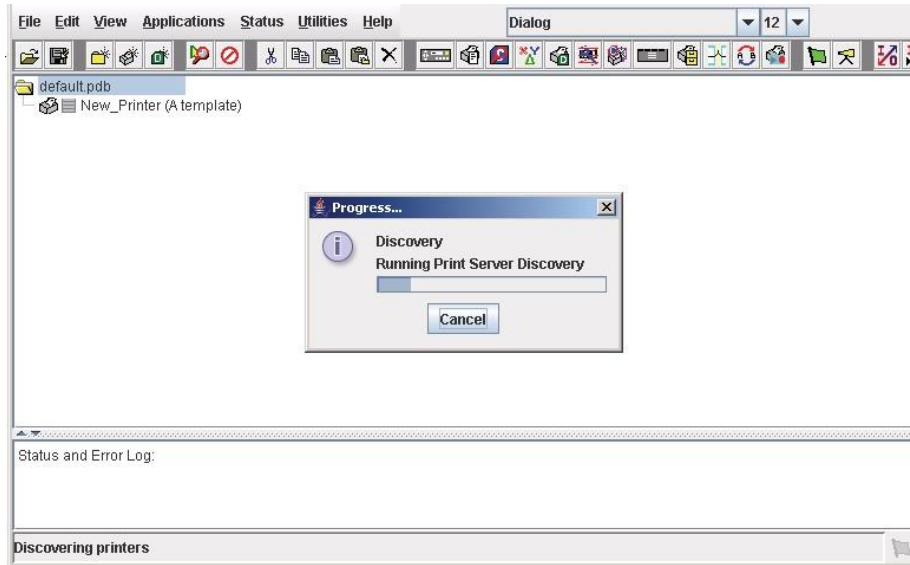

Figure 27 Print Server Discovery in Progress

If Enable Print Server Discovery is enabled, a progress indicator displays while PNE Auto ID discovers printers. See Figure 27.

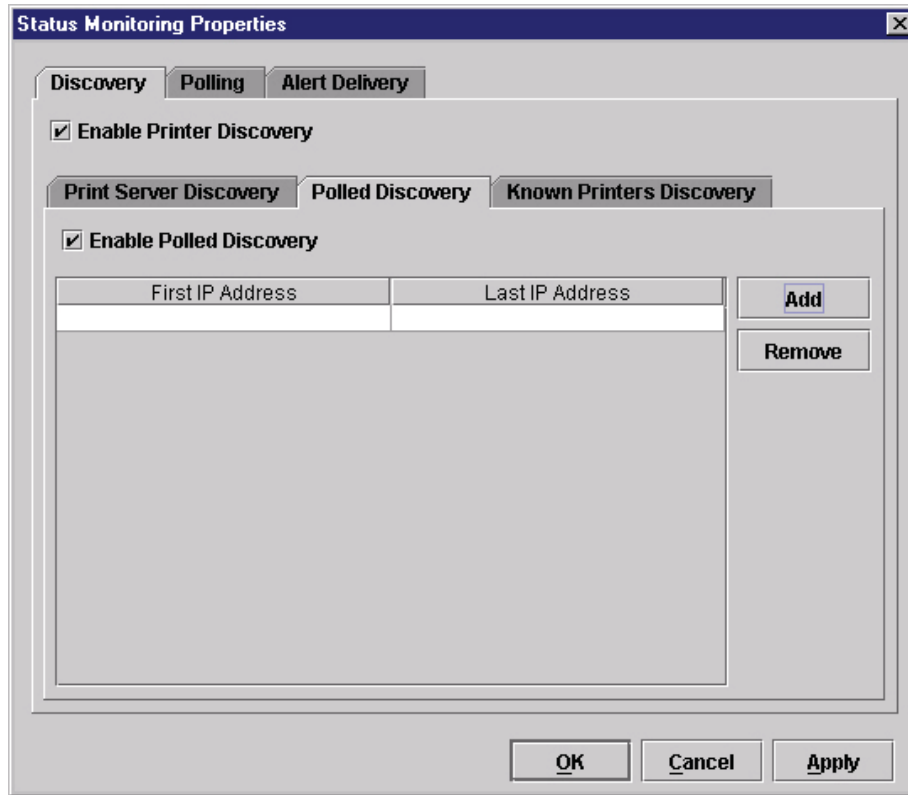

Figure 28 Status Monitoring Properties: Discovery Tab – Polled discovery Sub-Tab

2. **Polled Discovery:** This option allows you to select a range of IP addresses to poll. To enable the option, click the **Polled Discovery** tab and check the **Enable Polled Discovery** check box, then click **Add** (see Figure 28). In the First IP Address field, enter the first IP address of your desired range. In the Last IP Address field, enter the last IP address. Click **Apply** or **OK**. PNE Auto ID polls the printers within your specified range and displays the results in the database pane.

If Polled Discovery is enabled, a progress indicator displays while PNE Auto ID discovers printers. See Figure 29.

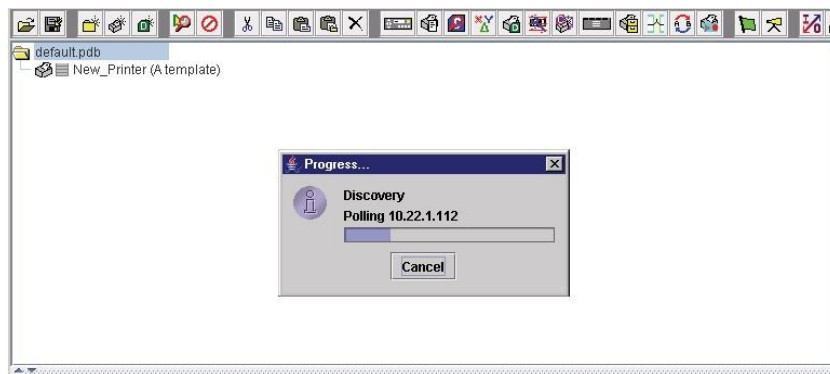

Figure 29 Polled Discovery in Progress

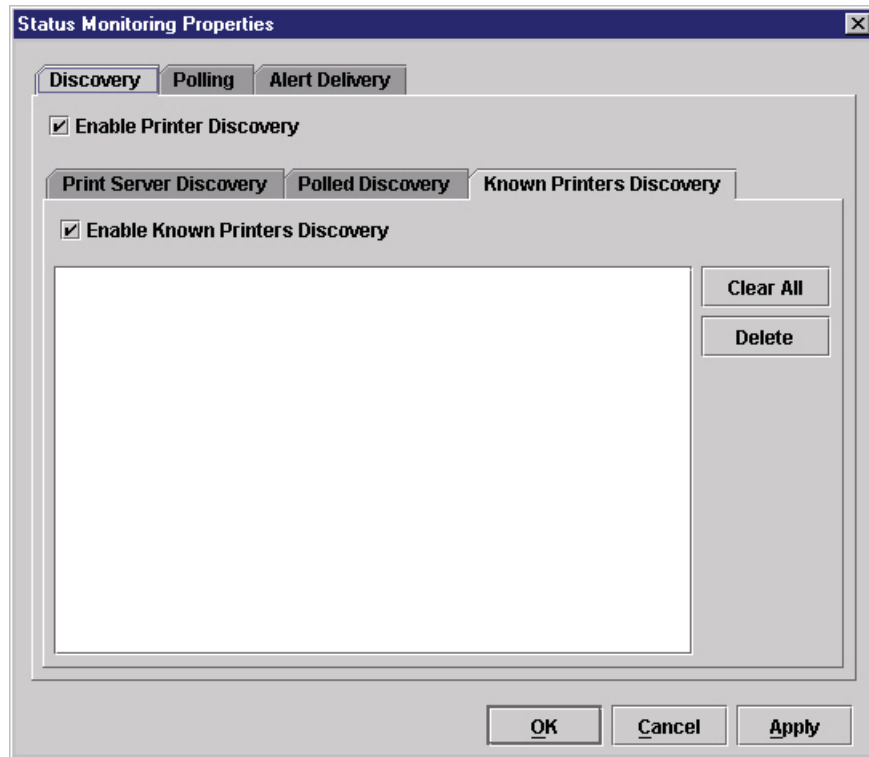

Figure 30 Status Monitoring Properties: Discovery Tab – Known Printers Discovery Sub-Tab

3. **Known Printers Discovery:** This option logs previously discovered printer IP addresses. From this log, you can select and delete previously polled discoveries to create a new polling list to target your printer search. To enable the option, click the **Known Printers Discovery** tab and check the **Enable Known Printers Discovery** check box (see Figure 30). From the polled list of IP addresses, refine your search by keeping or deleting found IP addresses. Click **Apply** or **OK** to start a new poll based on your specification.

NOTE: You cannot manually add an IP address to this list. If you delete an IP address, it is lost until it is rediscovered.

If Known Printers Discovery is enabled, a progress indicator displays while PNE Auto ID discovers printers. See Figure 31.

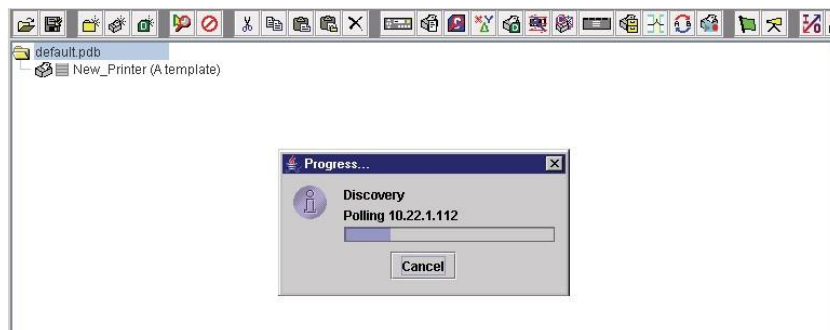

Figure 31 Known Printers Discovery in Progress

Polling Tab

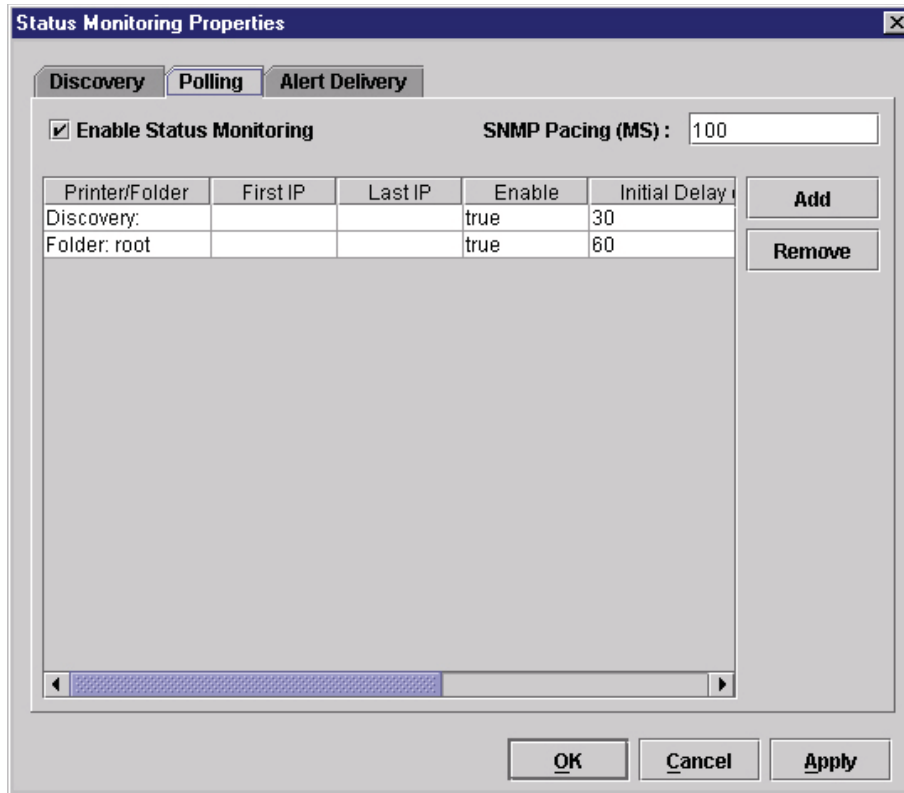

Figure 32 Status Monitoring Properties: Polling Tab

The Polling option allows you to control the way PNE Auto ID polls printers on the network. For instance, you can create a timed interval for PNE Auto ID to poll every 30 seconds or every two minutes. You can also specify a range of IP addresses.

To enable the option, check the **Enable Status Monitoring** check box in the Polling tab (see Figure 32). The SNMP Pacing (MS) value places a delay between each SNMP request. This feature minimizes the network load. By default, the value is set at 100 milliseconds (.1 second).

NOTE: If Discovery is enabled, then a discovery also occurs, based upon the settings in the Discovery tab (see Discovery Tab on page 42).

Now you can set parameters to a new task. The parameters include:

Printer/Folder: To select which printer or folder you want PNE Auto ID to poll. Click the field to select options from a drop-down menu.

First IP: To set the beginning IP address in a polling range. Use this option if you select **Range:** as the Printer/Folder option.

Last IP: To set the last IP address in a polling range. Use this option if you select **Range:** as the Printer/Folder option.

Enable: To select whether or not you want to enable polling of a specific task. If you want PNE Auto ID to poll the printers according to the specifications of your first task, select **true**. Otherwise, select **false**.

Initial Delay (S): To specify the time delay from when PNE Auto ID starts to when PNE Auto ID polls printers. The time delay is calculated in seconds.

Polled Interval (S): To poll printers automatically with timed intervals calculated in seconds. Use this option to periodically poll for new printers every few seconds.

Response Wait (MS): To specify the time delay PNE Auto ID waits between SNMP responses. By default, the value is set at 300 milliseconds (.3 seconds).

NOTE: If your network is overloaded and the responses are slow, you may not receive a response with the default setting. In this case, increase your Response Wait (MS) value.

NOTE: If you enter a low value for slow networks, you may receive no response. In this case, increase the Response Wait (MS) value.

Alert Delivery Tab

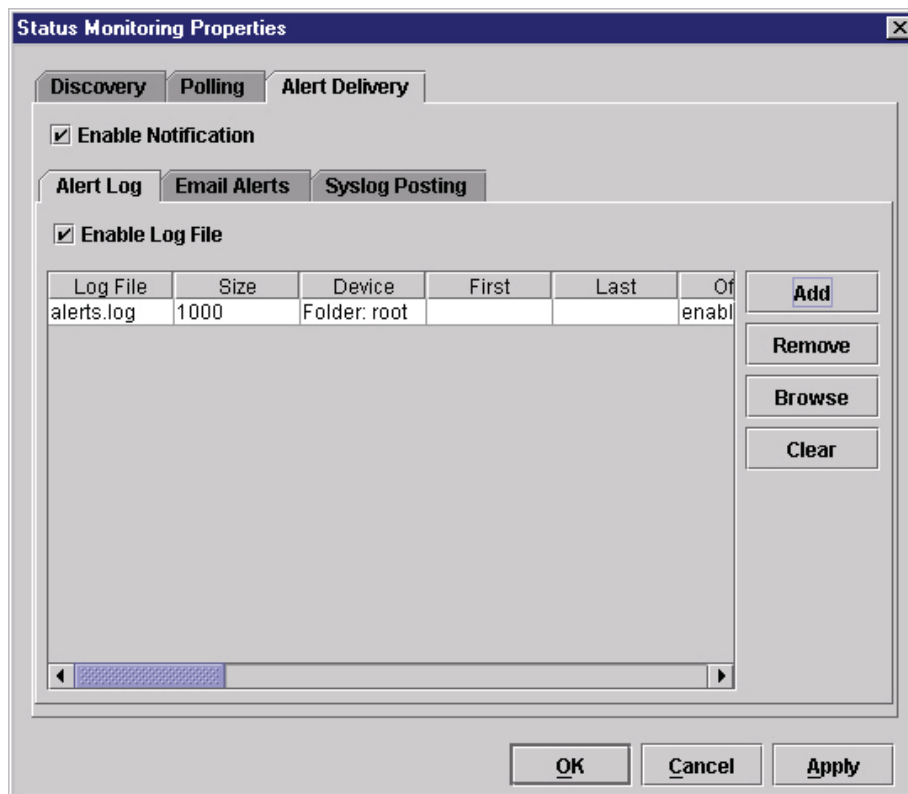

Figure 33 Status Monitoring Properties: Alert Delivery Tab – Alert Log Sub-Tab

Select **Status > Properties** to open the Status Monitoring Properties dialog box. Click the **Alert Delivery** tab. Check the **Enable Notification** check box to enable the option. The Alert Delivery properties allow you to customize the way PNE Auto ID notifies you of potential printer errors. Descriptions of the three alert types follows:

1. **Alert Log:** Allows PNE Auto ID to log alerts to a file located in the PNE Auto ID installation directory. To log alerts, check the **Enable Log File** check box, then click **Add** (see Figure 33). A task item adds to the log list. In the task item, specify the following as applicable, then click **Apply** or **OK**.

Log File: To name the log file. The default file name is **alerts.log**.

Size: To set the maximum file size, in bytes. The default (and minimum required) size is 1000 bytes.

Device: To choose a device item you want PNE Auto ID to monitor, such as a folder, specific printer, or a range of IP addresses.

First: To set the beginning IP address in a polling range. Use this option if you select **Range:** as the Device option.

Last: To set the last IP address in a polling range. Use this option if you select **Range:** as the Device option.

NOTE: In the remaining alert option fields, select **enable** or **disable** as desired.

Offline, Warning, Media Input, Media Output, Media Path, Marker, Cutter, Barcode, RFID, Scanner, Label, Intervention Needed, Consumables, and Power Cart: For a description of the alert groups and printer events, refer to “Alert Groups” in the SNMP Configuration section of chapter three in the *Network Interface Card User’s Manual*. All options are enabled by default.

To set up alert groups on the NIC, see Configure Print Servers on page 132.

Comment: Enter comments as needed.

The screenshot shows the 'Status Monitoring Properties' dialog box with the 'Alert Delivery' tab selected. The 'Email Alerts' sub-tab is active. The 'Enable Notification' checkbox is checked. The 'Enable Email' checkbox is also checked. The 'Outgoing Mail (SMTP) Server' field is empty. The 'Email Subject' field contains 'Printer Status'. The 'Email Sender' field contains 'printermanager@yourcompany.com'. The 'SMTP Email Server Port' field contains '25'. Below these fields is a table with the following data:

Email Address	Device	First	Last	Offline
	Folder: root			enable

Buttons for 'Add' and 'Remove' are located to the right of the table. At the bottom of the dialog are 'OK', 'Cancel', and 'Apply' buttons.

Figure 34 Status Monitoring Properties: Alert Delivery Tab – Email Alerts Sub-Tab

2. **Email Alerts:** PNE Auto ID sends you an alert e-mail if a printer error occurs. To set up Email Alerts, check the **Enable Email** check box. Enter information in the following fields:

Outgoing Mail (SMTP) Server: See your system administrator.

Email Subject: Enter the subject of e-mail.

Email Sender: Enter your e-mail address.

SMTP Email Server Port: See your system administrator.

Next, click **Add** to define a new task (see Figure 34). In the new task item, specify the following information, then click **Apply** or **OK**.

Email Address: Enter the e-mail address where you want PNE Auto ID to send the alert messages.

Device: To choose a device item you want PNE Auto ID to monitor, such as a folder, specific printer, or a range of IP addresses.

First: To set the beginning IP address in a polling range. Use this option if you select **Range:** as the Device option.

Last: To set the last IP address in a polling range. Use this option if you select **Range:** as the Device option.

NOTE: In the remaining alert option fields, select **enable** or **disable** as desired.

Offline, Warning, Media Input, Media Output, Media Path, Marker, Cutter, Barcode, RFID, Scanner, Label, Intervention Needed, Consumables, and Power Cart: For a description of the alert groups and printer events, refer to “Alert Groups” in the SNMP Configuration section of chapter three in the *Network Interface Card User’s Manual*. All options are enabled by default.

Comment: Enter comments as needed.

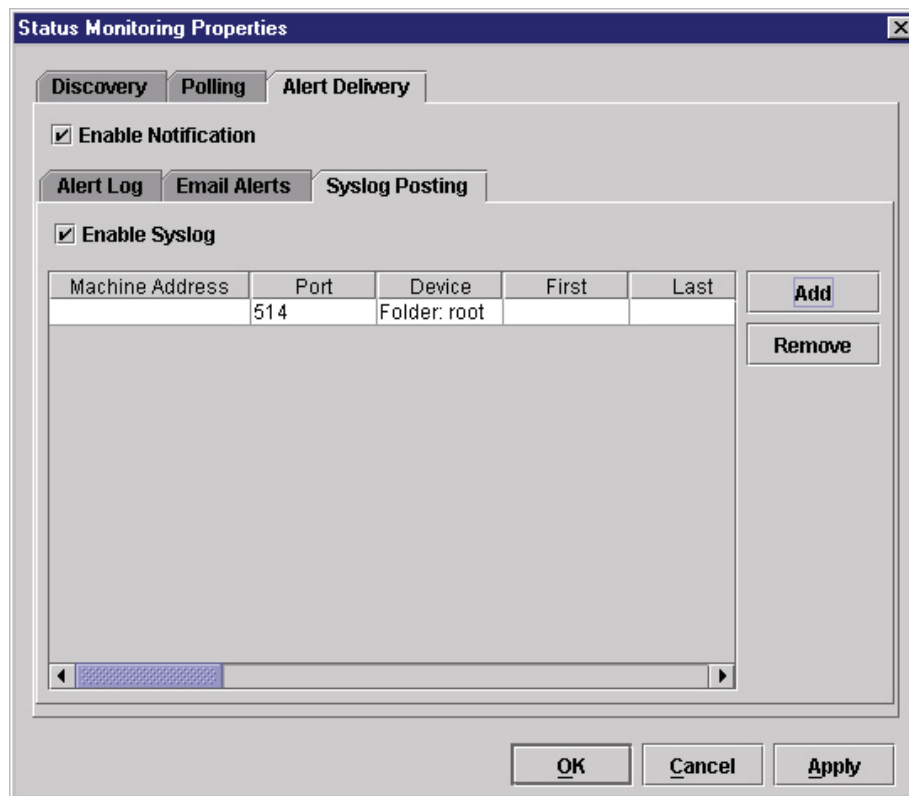

Figure 35 Status Monitoring Properties: Alert Delivery Tab – Syslog posting Sub-Tab

- Syslog Posting:** Used in a UNIX operating system, it allows PNE Auto ID to log alerts to a file located in the PNE Auto ID installation directory. To log alerts, check the **Enable Syslog** check box, then click **Add** (see Figure 35). A task item adds to the log list. In the task item, specify the following as applicable, then click **Apply** or **OK**.

Machine Address: The UNIX IP Address.

Port: See your system administrator.

Device: To choose a device item that you want PNE Auto ID to monitor, such as a folder, specific printer, or a range of IP addresses.

First: To set the beginning IP address in a polling range. Use this option if you select **Range:** as the Device option.

Last: To set the last IP address in a polling range. Use this option if you select **Range:** as the Device option.

NOTE: In the remaining alert option fields, select **enable** or **disable** as desired.

Offline, Warning, Media Input, Media Output, Media Path, Marker, Cutter, Barcode, RFID, Scanner, Label, Intervention Needed, Consumables, and Power Cart: For a description of the alert groups and printer events, refer to “Alert Groups” in the SNMP Configuration section of chapter three in the *Network Interface Card User’s Manual*. All options are enabled by default.

Comment: Enter comments as needed.

Update Status



Update Status shows the condition of the printer at the time the status is checked. To update the status of a printer, select **Status** > **Update Status**, or click the  (green flag) button at the right of the toolbar.

Figure 36 shows a printer with a wireless NIC that uses two ports. The  (signal strength) icon represents the wireless port, while the  (ethernet port) icon represents the ethernet port.

The printer’s model number, if available, displays in brackets following the printer icons. Current OEM printers display the OEM’s model number if it is placed in the Printer MIB. Future OEM printers (rebranded Printronix Auto ID printers), will not show the model number or the brackets after the printer icons.

The printer name is a user defined field that is used to distinguish a printer in the database. This field can be modified in the Printer Properties dialog box under the Identification tab. The name chosen must be unique from all the other printer names in the database and must use printable ASCII characters.

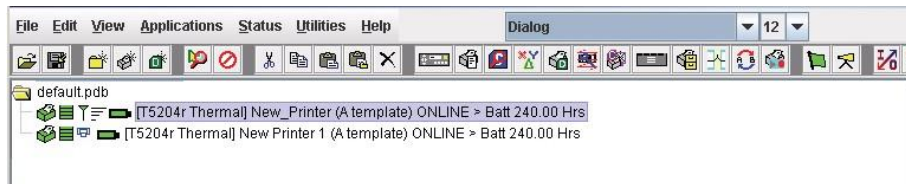



Figure 36 Update Status

When the printer status updates, the  (printer) icon may change color:

- Green indicates the printer is online, functioning properly, and can print
- Yellow indicates a warning, but the printer can print
- Red indicates the printer is offline or not functioning properly and cannot print
- Grey indicates that the printer is not recognized

The message to the right of the printer description is identical to the message on the operator panel.

If you enable status polling, the printer status updates automatically.

The  (ribbon supply) icon indicates the amount of ribbon remaining on the printer.

- Green indicates a full or nearly full ribbon supply
- Yellow indicates a moderate ribbon supply
- Red indicates a small or no ribbon supply
- Grey indicates one of the following:
 - The ribbon supply feature is not supported on the printer
 - For thermal printers, the printer is not using ribbon but rather direct thermal
 - For thermal printers, the printer has not printed since it was powered on, so PNE Auto ID cannot determine the amount of ribbon remaining.
 - The following three icons appear only if the features are installed.



The  (signal strength) icon indicates the strength of the radio signal.

- Green with three or four bars indicates a strong signal
- Yellow with two bars indicates a moderate signal
- Red with one bar indicates a weak or non-existent signal

The  (ethernet port) icon always remains blue, since it represents an ethernet connection.

The  (battery power) icon indicates the percentage of available battery power.

- Green indicates the battery has 61% to 100% available power
- Yellow indicates the battery has 20% to 60% available power
- Red indicates the battery has less than 20% available power

Place the pointer over the , , or  icon to obtain status information about the feature. See Figure 37, Figure 38, and Figure 39 on pages 51 and 52.

NOTE: No information displays if you place the pointer over the  icon.

The status information provided by PrintNet Enterprise varies based on the printer mode and/or the printer connection method. All USB connected printers will not have its status updated. To see the current printer status, use the virtual front panel. For T2N printer models, only basic status information will be available: Online or Offline.

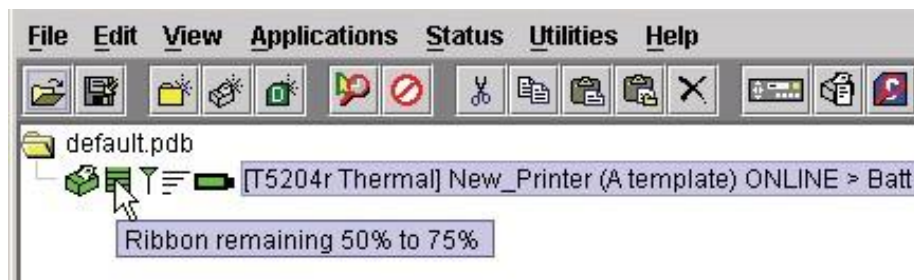

Figure 37 The Ribbon Supply Icon

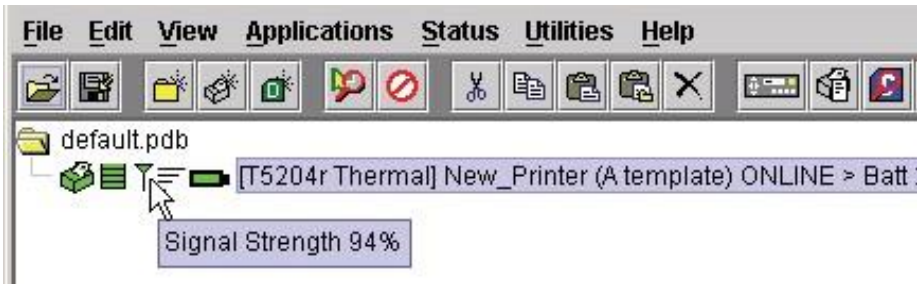

Figure 38 The Signal Strength Icon

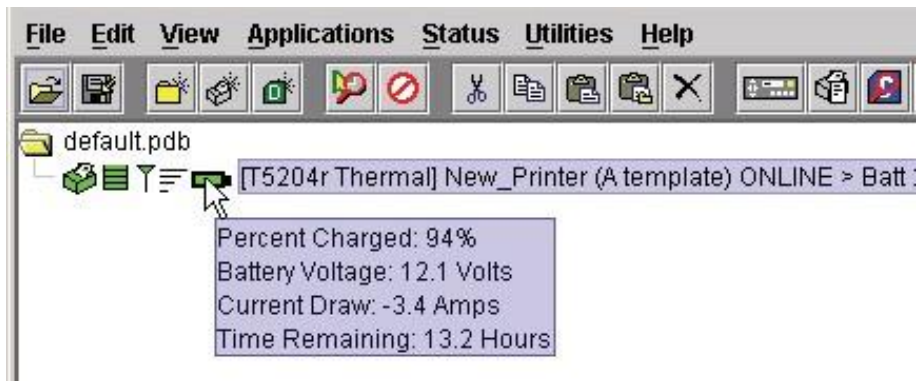

Figure 39 The Battery Power Icon

The Utilities Menu

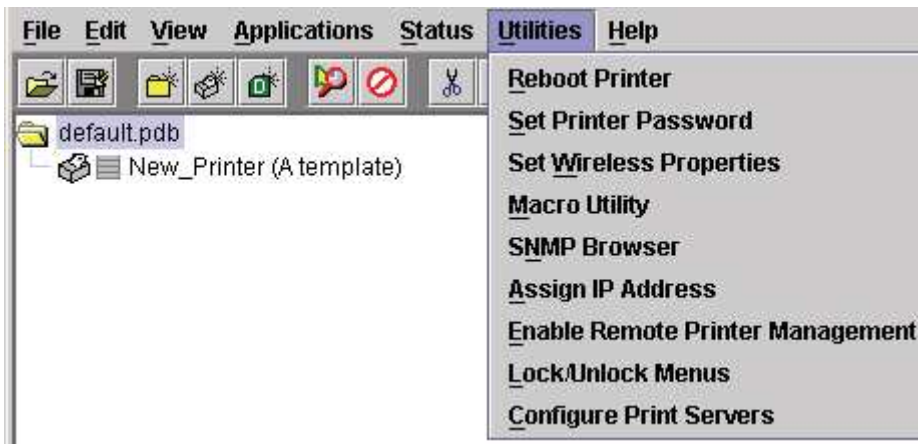

Figure 40 Utilities Menu

For an explanation of the Utilities menu options, find the menu option in Table 2 and go to the corresponding page.

Table 3 Utilities Menu Options

Menu Option	Page
Reboot Printer	page 117
Set Printer Password	page 117
Set Wireless Properties	page 118
Macro Utility	page 124
SNMP Browser	page 128
Assign IP Address	page 129
Enable Remote Printer Management	page 130
Lock/Unlock Menus	page 131
Configure Print Servers	page 132

The Help Menu

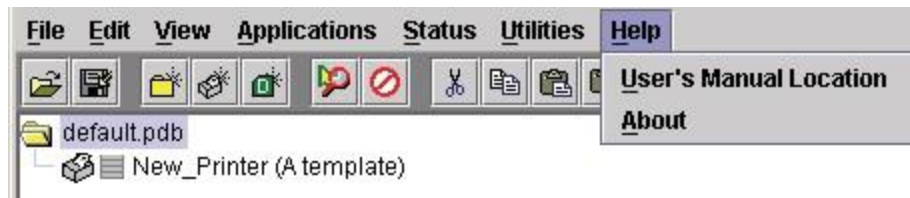

Figure 41 Help Menu

User's Manual Location

Displays the User's Manual Location dialog box. This dialog box tells you where to find the PNE Auto ID user's manual PDF file.















About















Displays the About dialog box. The About dialog box shows the PNE Auto ID program's version information and part number, and the Java version number.

The Toolbar

The PNE Auto ID toolbar contains buttons that perform functions. See below for a description of each button. Refer to the specified page for a more detailed description.

You can select which buttons display on the toolbar. See page 39.

Button	Description
	Open: Opens a different printer database.
	Save: Saves the current printer database.
	Folder: Inserts a new folder into the printer database (page 34).
	Printer: Inserts a new printer into the database (page 34).
	Download File: Inserts a new Download file into the database (page 34).
	Edit: Defines the properties of the selected item (page 56).
	Include/Exclude: Deactivates a selected folder, printer, or file (page 35).
	Cut: Removes a selected folder, printer, or file from the database and places it in the paste buffer (page 34).
	Copy: Copies a selected folder, printer, or file to the paste buffer (page 34).
	Paste After: Pastes the item in the paste buffer after the selected item (page 34).
	Paste Into: Pastes the item in the paste buffer into the selected item (page 34).
	Delete: Removes the selected item (page 35).
	Operator Panel: Virtual operator panel that allows you to make selections via PNE Auto ID as if you are using the physical operator panel (page 97).
	Information Capture: Allows PNE Auto ID to capture information sent between the computer and the printer (page 101).
	Configuration Editor: Allows you to edit the data sent from the computer to the printer before the printer receives it (page 65).

Button	Description
	Find Differences: Allows you to find the differences from the factory settings for all configurations (page 73).
	File Download: Allows you to download a configuration, firmware, or flash file to the printer (page 80).
	ODV Quality Wizard: Opens the ODV Quality Wizard window (page 104).
	Configure Print Servers: Opens the Configure Print Servers window (page 132).
	Speed Keys: Opens the Speed Keys window (page 105).
	Flash File Manager: Opens the Flash File Manager window (page 77).
	Media Profiler: Opens the Media Profiler window (page 90).
	CST Manager: Opens the CST Manager window (page 134).
	Job Capture: Opens the Job Capture window (page 106).
	Macro Utility: Opens the Macro Utility window (page 124).
	Update Status: Marks a printer or printers for status updates (page 50).
	Discover Printers: Searches for new printers (page 41).
	GPIO Manager: Opens the GPIO Manager window (page 181).
	AutoID Data Manager: Opens the AutoID Data Manager window (page 249).

Managing the Database

To organize your databases easily and effectively, use the Edit option on the printer database menu bar. You can add, delete, and assign printers, configuration files, and download files to your database tree. You can also organize them using folders. All Edit menu functions have buttons on the toolbar (see page 54).

Database Items

 **Folder:** Use folders to group the elements of your database.

 **Printer:** See Defining Printer Properties on page 56.

 **Download file:** A flash file or a configuration file (created in the Configuration Editor which is described on page 65) stored on your host computer.

A flash file contains information (e.g., the printer's firmware file or a font file) that you can download to the flash SIMM memory of a printer or group of printers.

A configuration file contains user-defined printer configurations that you can download to your printer using either the printer database or the Configuration Editor.

For information about Download files, see File Download on page 80.

Defining Printer Properties

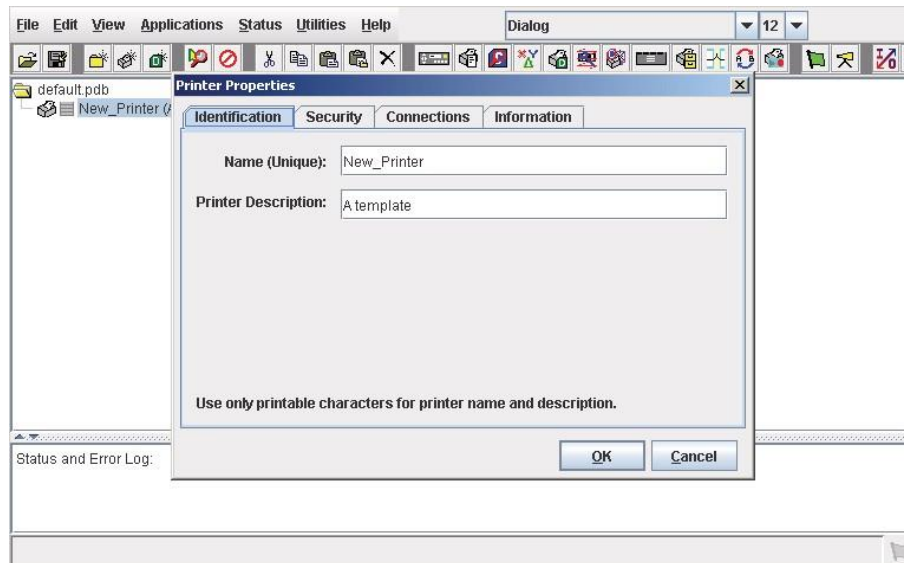



Figure 42 Defining Printer Properties

Before you can use any of the PNE Auto ID applications, you must define the printer's properties. You must identify the printer and configure how the printer communicates with PNE Auto ID. To define a printer, double-click the printer's name or click the  (edit database entry) button. The first time you run

PNE Auto ID, double-click **New_Printer (A template)**. The Printer Properties dialog box opens. See Figure 42.

The Printer Properties dialog box contains four tabs: Identification, Security, Connections, and Information, described in the next sections.

If the printer is USB connected, the Printer Properties dialog box displays the Security tab only. See Figure 43.



Figure 43 Defining Printer Properties for a USB Connected Printer

Identification Tab

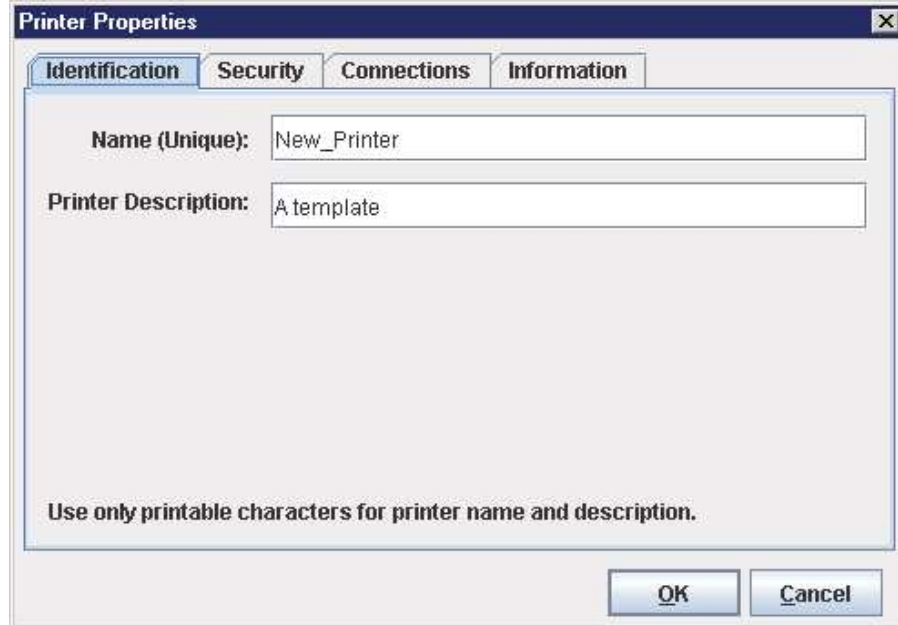

Figure 44 Printer Properties: Identification Tab

Name (Unique)/Printer Description: Assigns a name to your printer to identify it in the printer database. You can also assign a printer description, which appears in parentheses to the right of the printer name in the database.

When you assign a printer name and description, use only printable characters. Spaces may be used to separate words.

Security Tab



Figure 45 Printer Properties: Security Tab

User/Supervisor Password: Enter the printer's password, if appropriate. The password feature restricts access to certain functions of PNE Auto ID. In User mode, PNE Auto ID does not allow the following functions: downloading files, configurations, or configuration names to the printer; clearing the error log; and setting passwords. Supervisor mode allows unrestricted access to all functions of PNE Auto ID.

User and Supervisor passwords are only recognized up to 9 characters, and are displayed as *****, one * for each character typed. Use only printable characters for passwords. Spaces may be used to separate words. To set up a password, see Set Printer Password on page 117.

Telnet Guest Password: PNE Auto ID uses Telnet to read various printer settings.

IMPORTANT If you change the Telnet guest password, click OK and then the  (green flag) button (or select Status Y Update Status)..

Telnet Root Password: PNE Auto ID uses Telnet to update various printer settings.

IMPORTANT If you change the Telnet root password, click OK and then the  (green flag) button (or select Status Y Update Status)..

Telnet Guest Password Errors



Figure 46 Telnet Guest Password Error: Polling the Printer Status

PNE Auto ID uses Telnet to poll the printer status. If your printer reports a Telnet error (see Figure 46), enter the password for the user **guest** (page 58).

See your system administrator.



Figure 47 Telnet Guest Password Error: Reading Wireless Setting

PNE Auto ID also uses Telnet to read wireless printer settings (page 118). If PNE Auto ID reports a Telnet error when attempting to read wireless printer settings (see Figure 47), enter the password for the user **guest** (page 58).

See your system administrator.

Telnet Root Password Errors



Figure 48 Telnet Root Password Error

If PNE Auto ID reports a Telnet error when attempting to update wireless printer settings (see Figure 48), enter the password for the user **root** (page 58).

See your system administrator.



Figure 49 Enable Command Failed

PNE Auto ID also uses Telnet to enable remote printer management (see Enable Remote Printer Management on page 130).

If PNE Auto ID reports an error when attempting to enable remote printer management (see Figure 49), enter the password for the user **root** (page 58).

See your system administrator.

Connections Tab



Figure 50 Printer Properties: Connections Tab – Access Method Sub-Tab

The Connections tab contains three sub-tabs: Access Method, Network, and Serial/Modem.

Access Method Sub-Tab

Access Method: Identifies how PNE Auto ID accesses the printer. Refer to the *Network Interface Card User's Manual* to set up the NIC for your printer.

- **Ethernet:** To connect the host computer to the printer via the NIC.
- **Network (TCP):** To connect the host computer to the printer via a network interface.
- **Printer Serial Port (Direct):** To connect the host computer to the printer directly via the serial port.
- **Printer Debug Port (Direct):** To connect the host computer to the printer directly via the debug port.
- **Printer Serial Port (Modem):** To connect the host computer to the printer via a modem and the serial port.
- **Printer Debug Port (Modem):** To connect the host computer to the printer via a modem and the debug port.

Download Mode: Identifies how PNE Auto ID downloads files and configurations to the printer. Access Method is the only option available.

Printer Timeout on Firmware Download: Specifies the number of minutes the printer waits for data while downloading a file from the host computer. If a stall lasts for more than the specified time, the printer times out and the download terminates. If you have a slow connection between PNE Auto ID and the printer, you may need to define a longer Download Timeout period.

The Download Timeout range is between 1 and 60 minutes. The default is 2 minutes.

Firmware Download Initial Delay (Sec): Specifies the number of seconds PNE Auto ID waits before sending files to the printer. If the printer is not ready within the specified time, the download will terminate, and the Status and Error Log will report Connection Refused.

If you receive this error message, increase the initial delay time. The default is 60 (seconds).

Network Sub-Tab

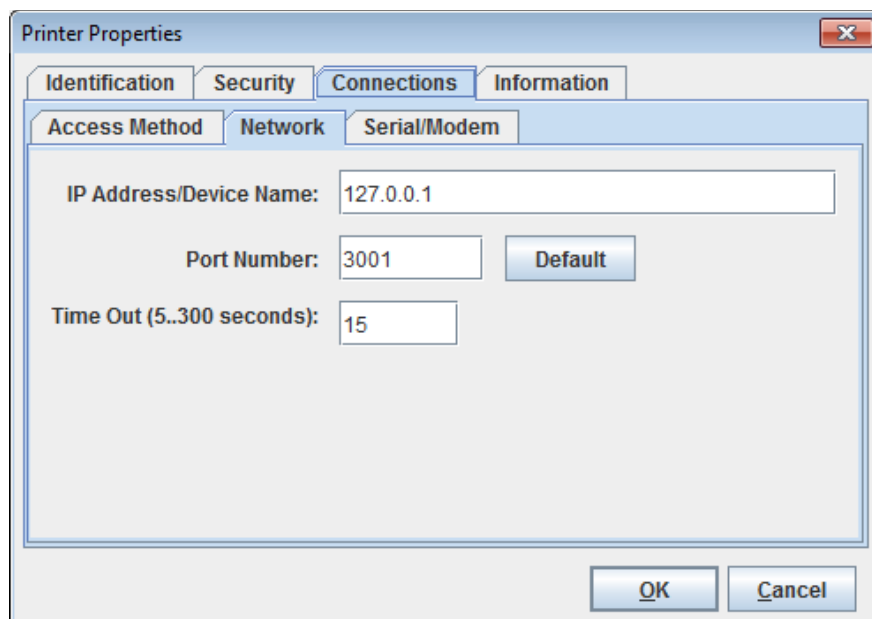

Figure 51 Printer Properties: Connections – Network Sub-Tab

Enter the printer's IP Address (or host name) and Port Number. (Click **Default** to reset the Port Number to 3001.) The Time Out option sets the amount of time, in seconds, PNE Auto ID waits for a response from the printer after sending a command. If there is no response in the specified amount of time, an error message appears in the Status and Error Log pane. If you have a slow connection between PNE Auto ID and the printer, you may need to define a longer Time Out period. Define the Time Out between 5 and 300 seconds (the default is 15 seconds).

NOTE: The Network settings must match the settings in the operator panel menu. See "ETHERNET PARAMS", "ETHERNET ADDRESS", or "WIRELESS ADDRESS" in the printer's *Administrator's Manual* to check the IP address.

To check the port number on the printer, see Check Port Number on page 14.

Serial/Modem Sub-Tab

The Serial/Modem tab contains two tabs: Serial Port Parameters and Modem Control.

Serial Port Parameters

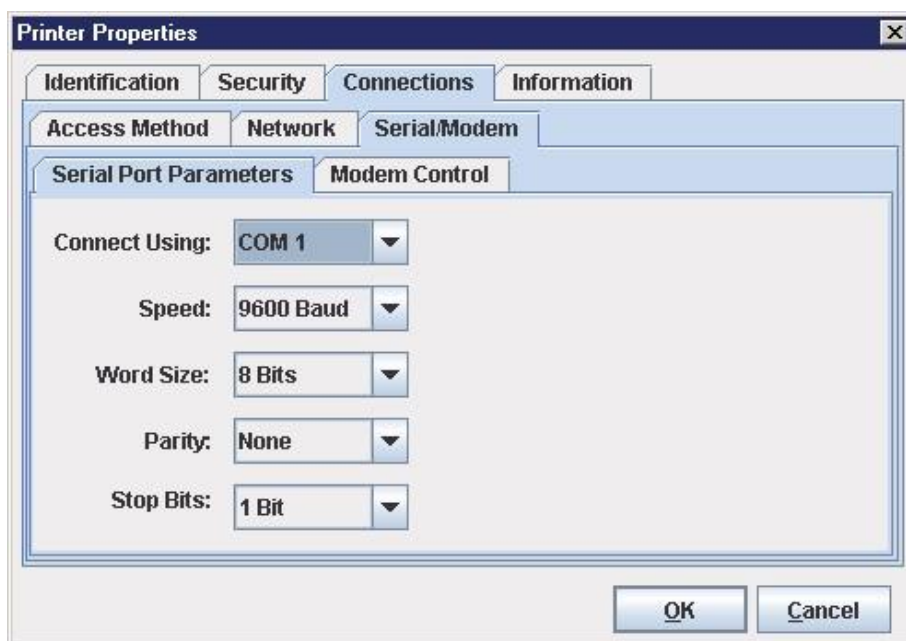

Figure 52 Printer Properties: Connections – Serial/Modem Sub-Tab Serial Port Parameters

Connect Using: The serial port to use for connection. The default is COM1. The range is COM1 to COM20.

Speed: The baud rate at which data transfers. This setting must match the speed of the printer serial debug port. See Table 4 to determine the serial debug port baud rate menu location for your printer model

Table 4 Serial Debug Port Baud Rate Menu Location

Printer Model	Menu
SL4M/T4M	INTERFACES √ Printer Mgmt √ Baud Rate
SL5000r/T5000r	PRINTER MGMT or Factory √ Baud Rate
P7000	PRINTER MGMT √ BAUD RATE

Word Size: The number of data bits per character. Must be set to 8 bits.

Parity: Adds an error checking bit if set to Odd or Even. Since the word size must be set to 8 for correct operation, parity should normally be set to None.

Stop Bits: Inter-character gap. Can be set to 1 or 2. The normal setting is 1.

Modem Control

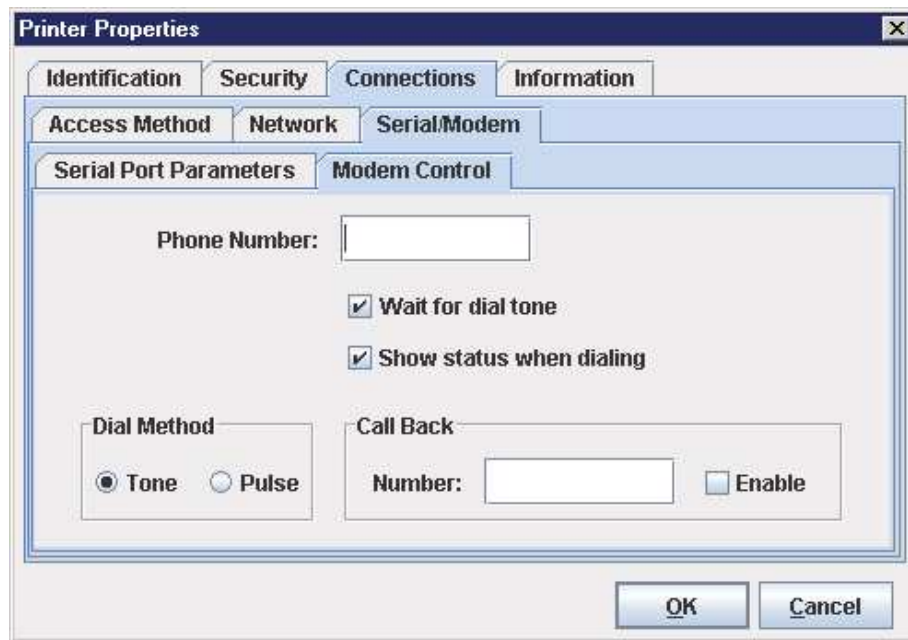

Figure 53 Printer Properties: Connections – Serial/Modem Sub-Tab Modem Control

Phone Number: Enter the phone number you wish to call.

Dial Method: Choose Tone or Pulse.

Call Back: Enter your phone number, and check Enable if you want to use it as a call back number.

Information Tab



Figure 54 Printer Properties: Information Tab

Contains information about your printer. Refer to the *Network Interface Card User's Manual* for more information.

3 Applications and Web Access

Configuration Editor

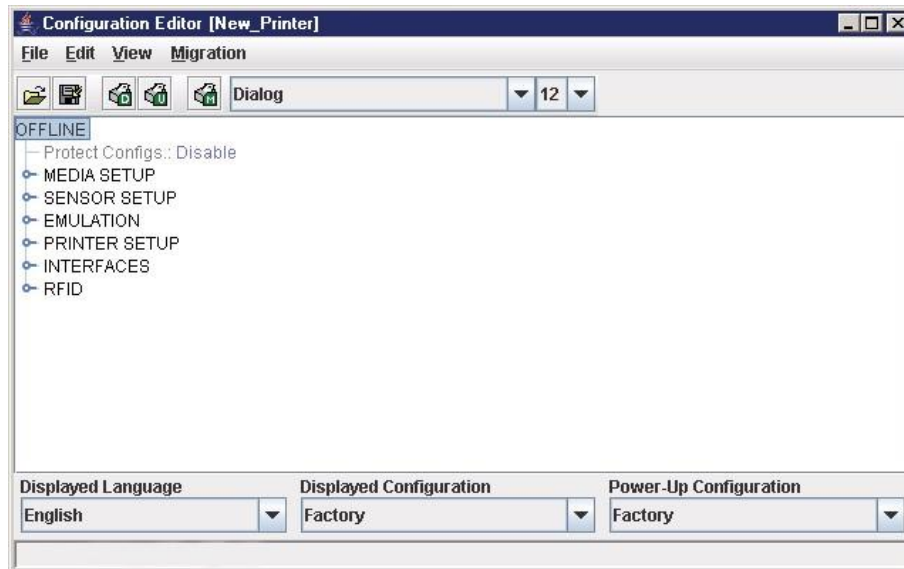



Figure 55 Configuration Editor Window



To access the Configuration Editor application, select a printer from the printer database and select **Applications ► Configuration Editor** or click the  (configuration editor) button. Select **File ► Upload From Printer** to upload configurations from the printer. The configurations upload from the printer and the active configuration displays in the Configuration Editor window. See Figure 55.

The Configuration Editor supports offline editing, allowing the editing of stored configurations. If you start the Configuration Editor without connecting to a printer, the screen will be blank (indicating no configuration loaded). A configuration will not display until you load a configuration file from a disk or computer.

The Configuration Editor allows you to upload, modify, and download eight user-defined configurations and the factory default configuration (only if modification of the factory configuration has been enabled; see the NOTE on page 66). You may also save sets of configurations to your local hard drive so that they can be easily downloaded to the printer at any time.

The Configuration Editor does not change the current configuration or the active printer status until the configurations are downloaded to the printer.

Menu Tree

The Configuration Editor displays the printer configurations in a tree format (see Figure 55). The top level of the tree is the OFFLINE menu. From this level, the tree branches into the printer's submenus. Menu items that have a  or  (handle) next to them have further submenus below them. Click the handle to expand or collapse the submenus below. (You may also use the Expand Tree/Collapse Tree options in the View menu, but these options will expand or collapse all submenus.)

The Configuration Editor has three drop-down menus at the bottom. The Displayed Language option allows you to select from five or more different languages to display the configuration information. The Displayed Configuration option lets you choose between the available configurations to display. The Power-Up Configuration allows you to assign which configuration loads whenever the printer turns on.

Creating Configurations

Along with the factory configuration, your printer allows up to 8 user-defined configurations that can be downloaded to your printer's memory. You may create configurations using the operator panel or by using the Configuration Editor.

To create a configuration using the Configuration Editor:

1. Select **Edit ► Copy From:**. A list of configurations appears. Undefined configurations appear gray. Choose one of the configurations.
2. Click **Edit**. (Notice that the configuration you chose in step 1 now appears next to the Copy From: menu item.) Move your mouse down to **Copy To**. A list of configurations appears. Choose the number of the configuration you want to create. This new configuration is created with the settings from the configuration you chose in step 1.

NOTE: If you choose to **Copy To** a configuration which already exists, that configuration will be overwritten.

3. You may now edit the configuration settings. See Changing Configurations on page 66.

Changing Configurations

Configuration settings in the Configuration Editor can be changed two ways:

- make the changes directly on the menu tree
- use the Menu Editor

NOTE: Normally, the factory default configuration cannot be changed. However, you can enable modification of the factory configuration. Select **Edit ► Enable Factory Edit**. It is strongly recommended that you do *not* modify the factory default configuration. If you choose to modify the factory configuration, you should first upload it from the printer, and then save it. This way, you will have a backup copy of the factory configuration. To disable modification of the factory configuration, select **Edit ► Disable Factory Edit**.

Making Changes on Menu Tree

1. Using the Displayed Configuration menu at the bottom of the window, click the drop-down arrow to choose the configuration to change.
2. Expand the submenus until the configuration setting you want to change displays.
3. Select the menu item you want to change. A selection box surrounds your choice. See Figure 56.

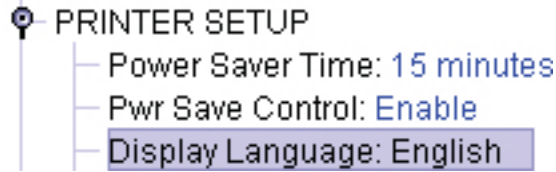

Figure 56 Selecting a Menu Item

4. Double-click an item to open the Menu Editor (page 67) for that item, or use the < and > keys to toggle through the available options. See Figure 57. (You may change these keys in the printer database window: select **File ► Preferences**, then click the **Configuration Editor** tab. See page 26).

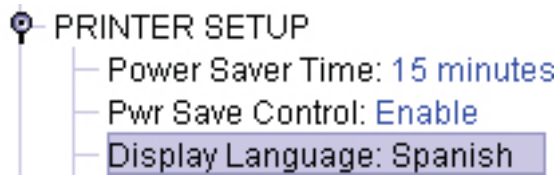

Figure 57 Toggling Through The Available Options

Menu Editor

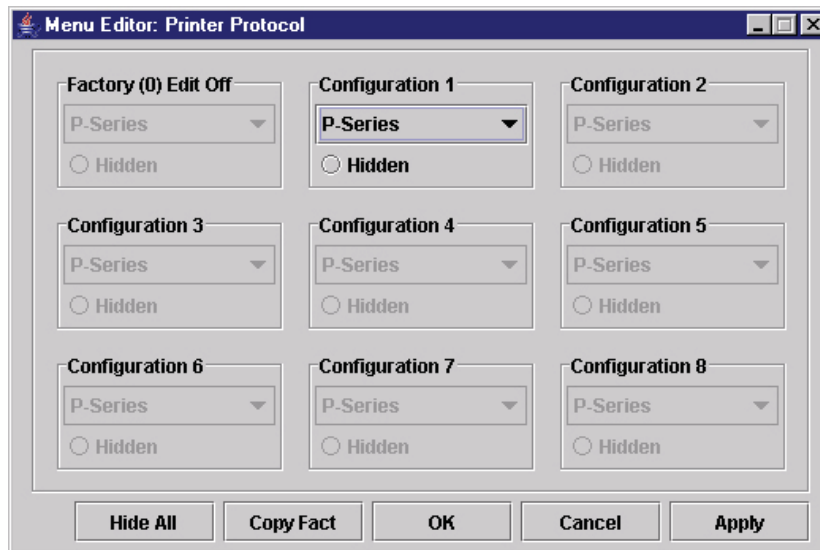

Figure 58 Menu Editor

Double-click any menu item to open the Menu Editor window. Figure 58 shows the screen you see when you double-click the Printer Protocol option. By using the Menu Editor, you may view and adjust the settings of all nine of the printer configurations at once. To change a setting, click the drop-down arrow underneath the corresponding configuration and choose an option.

Grayed out configuration names and settings do not exist; you must create the configuration before you can edit it (see page 66).

To hide a menu item in the operator panel, select Hidden under a configuration. Click **Hide All** to hide this menu item in all configurations. (For more information on hiding, see page 68.)

Select **Copy Fact (1-8)** to set all configurations to the same value as the factory or user-defined configuration currently selected under the Edit ► Copy From: menu in the Configuration Editor (see page 66).

Click **Cancel** to exit the Menu Editor without saving your changes.

Click **Apply** to save your changes without exiting the Menu Editor.

Click **OK** to save your changes and exit the Menu Editor.

Deleting Configurations

To delete any of the configurations (except the factory configuration), select **Edit ► Delete ►** and choose the number of the configuration to be deleted.

Naming Configurations

You may name any of the eight user-defined configurations using an alphanumeric string of 1 to 15 characters. Select **Edit ► Names** to open the Edit Configuration Names window.

Choose the configuration you want to name, then click **OK** to assign the name change, **Cancel** to exit this window without saving your changes, or **Reset** to restore the original configuration numbers.

Hiding/Unhiding Menu Items

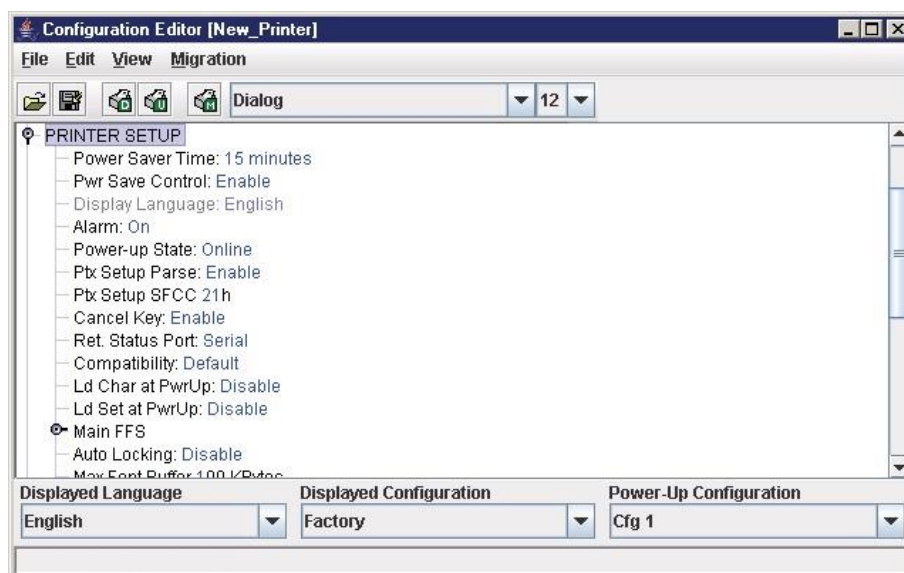

Figure 59 Hiding a Menu Item

The Configuration Editor allows you to hide menus to make the operator panel menus easier to use, or to restrict printer operators from accessing certain printer configuration menu items. If you choose to hide a menu item in the Configuration Editor, the hidden menu item still loads into the printer when the configuration downloads to it. However, the hidden menu item does not appear on the operator panel.

The Configuration Editor displays hidden menus in gray on the menu tree. When a menu item is hidden, all of its sub-menus are hidden as well.

In Figure 59, the Display Language menu item is hidden. The Display Language menu item cannot be changed from the operator panel.

IMPORTANT Depending upon the active emulation, active interface, or hardware attached to the printer, some menu items cannot be hidden on the operator panel, even though they may be defined as “hidden” in PNE Auto ID.

You can still change hidden menu items using the Menu Editor.

You can hide or unhide menu items in three ways:

1. In the menu bar, select **View ► Hide/Unhide Menus**. With this menu option, you may hide or unhide individual items, sub-menus or the entire configuration.
2. Using the Menu Editor. See page 67.
3. Using the keyboard. From the menu tree, select a menu item. A selection box appears around the selected menu item. Press **H** to hide the menu item or **U** to unhide the menu item. (To change these keys, select **File ► Preferences** in the printer database window. See page 25.)

Saving Configuration Files

Normally, your printer can save only nine configurations in its memory. You change these configurations through the operator panel. However, using PNE Auto ID, you can store a nearly unlimited number of configurations on your host computer.

Once you have made your changes, you can save your configurations as a **.cfg** file on your local hard drive. This way, you can open any set of configurations from your host computer and download them into your printer quickly and easily.

To save configurations to your local hard drive, select **File ► Save As**. Be sure to save your configuration as a **.cfg** file.

It may be necessary to save a configuration file in the format used by previous versions of PNE Auto ID. In this case, select “Legacy Configuration File” from the Files of Type: list and select the file to be saved.

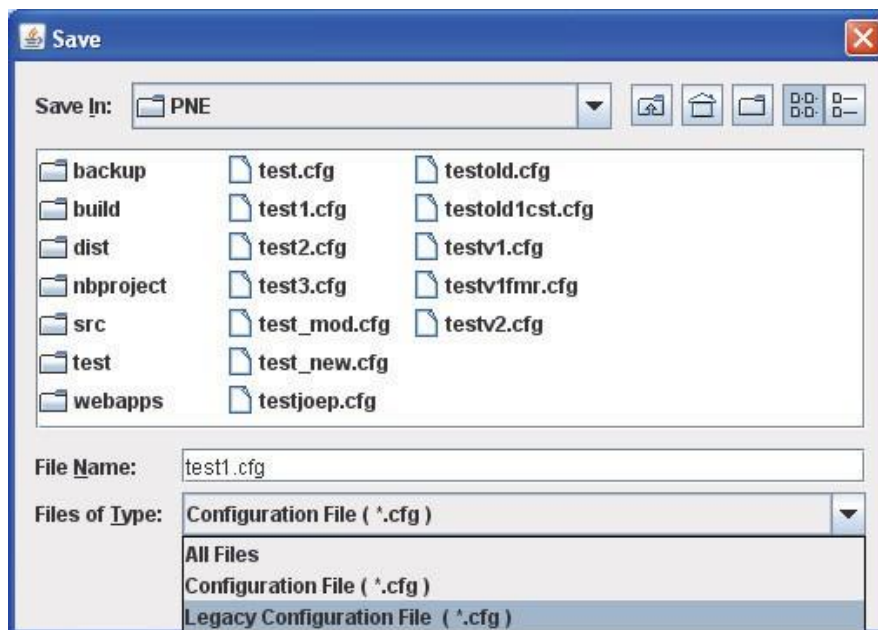

Figure 60 Saving as a Legacy Configuration File

Opening Configuration Files

To open a configuration file, select **File ► Open**. The Configuration Editor loads the settings from the file you choose.

IMPORTANT These settings do not affect the current configuration or the active printer status until the configurations are downloaded to the printer.

NOTE: The Configuration Editor displays only one configuration file at a time. Be sure to save any changes before opening another configuration file.

If you load a configuration file that was created with PNE Auto ID version 3.03H or earlier, you may need to link the affiliated CST file. In this case, select **File ► Open** again, and check the **Link CST File** check box. See Figure 61. Navigate to the affiliated **.cst** file and double-click it (or single-click it and click the **Select** button). Save the configuration file, and the CST information will save to the new configuration file. (You will not need to link the CST file in the future.)

NOTE: If you hover the pointer over the **Link CST File** check box, a screen tip appears that describes this functionality.

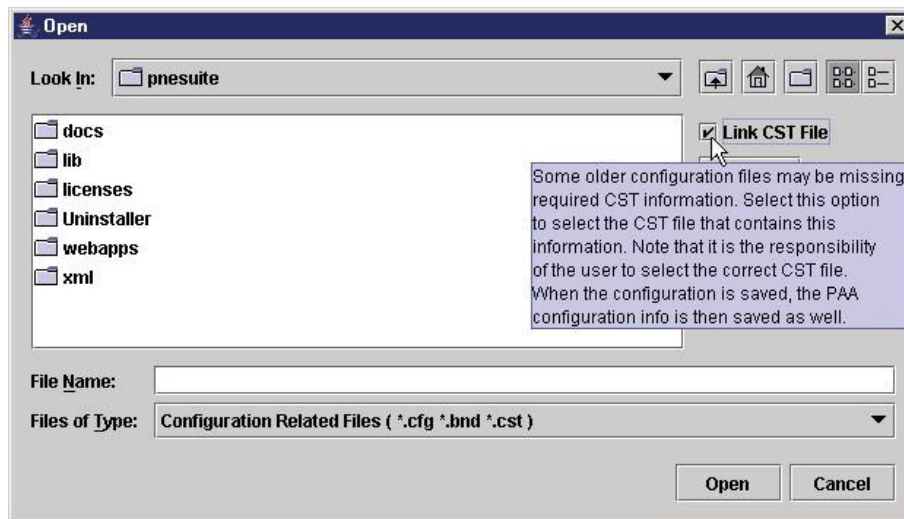

Figure 61 Linking a CST File

Downloading Configurations

You may use the Configuration Editor to download into your printer any configurations you have created. Open the configuration file you want to use, then select **File ► Download To Printer** to send individual configurations, all configurations, or just the configuration names.

Downloading a configuration overwrites the corresponding configuration currently stored in the printer. If you want to save the configurations currently stored in the printer before overwriting them, upload them into the Configuration Editor first, and then save them as a **.cfg** file on your local hard drive.

NOTE: Be sure to calibrate your thermal printer after you download a configuration to it. See “Running Auto Calibrate” in the printer’s *Administrator’s Manual*.

NOTE: Downloading a configuration file does not immediately update the printer’s active configuration. You must activate a downloaded configuration using the Load Config. setting in the operator panel. Refer to the printer’s *Administrator’s Manual* for details.

Uploading Configurations

The Configuration Editor can upload configurations from a printer. Select **File ► Upload From Printer**. Once the configurations upload, you can save them to a file. Now you can select another printer from the database and upload its configurations. PNE Auto ID prompts you to save the previously uploaded configuration before the new configuration uploads.

Migration

Over time, menus and functions changed to reflect the new features of the printers. Some printer features have been removed to provide better or more complete printer features. Older saved configurations may have used these removed features or contain settings that no longer exist or have been modified in new printer firmware. This can cause potential problems when downloading new printer firmware while preserving previously saved configurations if the saved settings are not analyzed and adjusted to work with the new firmware. This analysis and adjustment has been summarized into one word: migration.

Transferring Saved Settings

Original Method

To ensure that your settings from the saved configuration are set correctly in the printer: print out the old configurations, download the configurations to the printer, print out the new configurations, and compare the old settings with the new settings.

If you need to make changes: upload the configurations to the Configuration Editor, make changes, and re-download to the printer.

Enhanced Method

Using the migration utility in the Configuration Editor, all these things can be done without having to download the configurations to the printer until you know they are correct. No migrated settings will be downloaded to your printer until you download them. This way you can run the migration, view the results, view the report, and make any necessary changes without affecting your saved configurations or the configurations in the printer.

How To Use The Migration Utility

STEP 1:

Load the configurations settings that need to be migrated into the Configuration Editor before using the migration utility.

Migration Limitations

Only attempt to migrate saved configuration settings from printers of the same model type and the same emulations. An example of a different printer model type is a thermal printer configuration to a line matrix printer.

The printer that you are going to migrate the settings to should be a superset of or contain the same emulations as the saved configurations. For example, migrate saved settings that contain an ANSI emulation on a line matrix printer to another line matrix printer that contains ANSI and PGL. Do not migrate these same saved settings to a line matrix printer that does not contain ANSI. The migration utility does not prevent you from doing this, but the results would be useless and could cause problems if the migrated configurations were downloaded and then loaded on a different printer type.

IMPORTANT **Make sure the printer model type and emulations of the saved configurations match the printer model type and emulations of the printer you want to migrate the settings to before attempting to migrate the saved settings.**

Loading Configuration Settings

The configuration settings to migrate can be opened using the Configuration Editor in the following ways:

Loading From a File

Click the  (open configuration file) button or select **File ► Open**. Choose your configuration file and then click **OK**.

Loading From a Printer

Select a printer in the printer database. Click the  (upload configuration) button or select the **File ► Upload From Printer** to upload the settings.

STEP 2:

Select a printer and begin the migration of the saved configuration settings.

Select a Printer to Use for Migration

Select a printer in the printer database. The printer you select must have new printer firmware. If it does not, exit the Configuration Editor and download new firmware to the selected printer (see File Download on page 80), then select the printer in the printer database.

Start the Migration

Click the  (migrate) button or select **Migration ► Run Migration**. Several messages will appear in the bottom left corner of the Configuration Editor that indicate the progress of the migration.

STEP 3:

View the results using the Configuration Editor.

The results will display graphically in the Configuration Editor.

Several different icons will display depending on the migration. Hover the pointer over an icon to display a short description. A icon can represent several types of changes. The migration report details these changes (page 73).

Select **Migration ► View Results** to see the migration results.

This menu has the following submenus:

Original Configurations

All Menus: Displays the original configuration settings with the menus that were removed from the original configurations.

Removed Menus: Displays only the menus that were removed from the original configurations.

Migrated Configurations

All Menus: Displays the migrated configuration settings including all of the menus that were modified.

Modified Menus: Displays only the menus that were modified by the migration of the saved settings.

If you select **Modified Menus** and then select **View ► Expand Tree**, all of the menus that were affected by the migration will display in a simplified view.







Migration Icon Definitions



Indicates a new menu or a new set of menus.



Indicates that the menu previously existed in the saved configurations and was added to another menu.

-  Indicates that the menu previously existed in the saved configurations and was moved to another menu, or removed from the current menu but still exists in the saved configurations.
-  Indicates that the menu was completely removed.
-  Indicates that this menu or a submenu has changed. The change can be various things such as range or increment.
-  Indicates that additional selections have been added to this menu.
-  Indicates that selections have been removed from this menu.
-  Indicates that this menu has been replaced with another menu or the menu definition has changed.

STEP 4:

View the results using the Migration Report Viewer.

Select **Migration ► View Report** or double-click the  **Migration Report** icon (located at the top of the migrated configurations display) to open the Migration Report Viewer.

The Migration Report Viewer displays a detailed textual report of the information that displays graphically in the Configuration Editor. Use the Migration Report Viewer to view, save, or print the report.

NOTE: It is recommended to use landscape mode when printing the migration report.

The report contains the following types of messages:

Informational Messages: Menu settings that migrated without problems. They display to inform you that there was a change during the migration.

Warning Messages: Menu settings that attempted to migrate to the new configurations and were changed. Analyze these settings to determine if they are desirable.

Intervention Messages: Menu settings that could not migrate to the new configurations. This could occur when a menu item was completely removed and the user utilized a setting other than the default. In this case the Migration Utility cannot decide what action to take.

IMPORTANT **You must resolve intervention messages, or the printer may not operate properly.**

STEP 5:

Post-migration.

After you review the migrated configuration, save, delete, or download the migrated configuration file to one or more printers using PNE Auto ID.

Factory Settings Differences

The Factory Settings Differences application allows you to keep track of migration from old to new printers. It displays the differences between the Factory configuration settings and all other saved configuration settings. The differences are highlighted to show value differences between configurations.

Two views displaying the data are available. The All Settings view shows all of the menus, highlighting the value differences. The Differences Only view shows the menus and its corresponding values that differ from the Factory settings.

To access the Factory Settings Differences application, select **Applications ► Factory Differences** or click the  (find differences) button. The application opens with no configuration data loaded. The Factory Settings Differences window contains three sections: the menu bar, toolbar, and the configuration settings differences pane. See Figure 62.

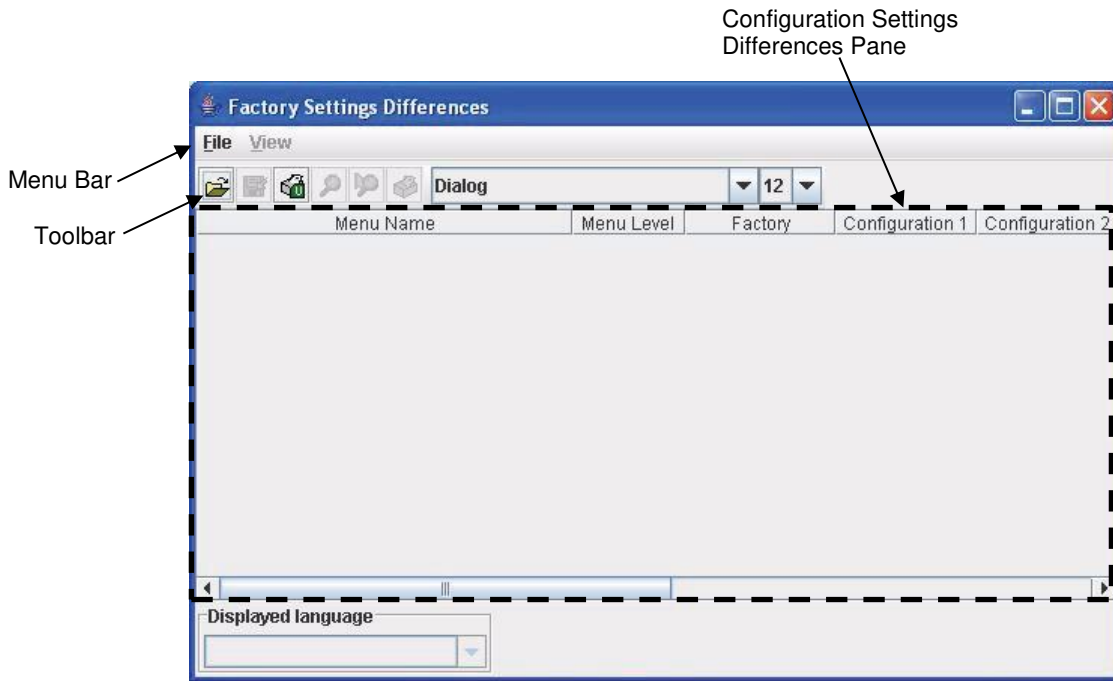

Figure 62 Factory Setting Differences Window

Menu Bar

The menu bar consists of a File menu and a View menu.

File Menu

<u>F</u> ile	<u>V</u> iew
<u>O</u> pen	Ctrl-O
<u>U</u> pload Differences	Ctrl-U
<u>S</u> ave	Ctrl-S
<u>S</u> ave As	Ctrl-A
<u>P</u> rint	Ctrl-P
<u>E</u> xit	Ctrl-E

Figure 63 Factory Settings Differences - File Menu

Open

The Open submenu allows you to select and open a previously saved Factory Settings Differences file. The file must be one that was created with this application.

NOTE: No error checking is available for an invalid file type, including Comma Separated Variable (CSV) formatted files that were not created by this application.

Upload Differences

The Upload Differences submenu uploads the configurations and determines the Factory settings differences. The results display in a table in the All Settings view.

Save and Save As

The Save and Save As submenu allows you to select and save the Factory setting differences file to a file. The results table can only be saved in the Differences Only view. You will be informed if you try saving the file in the All Settings view. The saved file will be in CSV format.

Print

The Print submenu allows you to set up printing preferences and print the differences table. You can print the differences table in both views.

View Menu

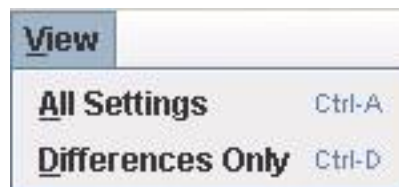

Figure 64 Factory Settings Differences - View Menu

All Settings View

The All Settings view displays all of the menus in the configuration, highlighting the menus that are different from the Factory settings and their values. The menu name and its associated values are highlighted in different colors for easy distinction. See page 75.

Differences Only View

The Differences Only view shows the top level menus and the menus that have configuration values that are different than the Factory settings. Since this view only shows the differences, the menu names are not highlighted. The menu values are highlighted for easier distinction. See page 75.

Toolbar



Figure 65 Factory Settings Differences - Toolbar

The toolbar contains buttons for Open, Save, Upload Differences, All Settings View, Differences Only View and Print. These buttons perform the same actions as their menu counterparts. The toolbar also has font selection and size boxes to allow user selectable preferences.

Configuration Settings Differences Views

This view consists of a non-editable table that displays the menu name, the menu level, the Factory default settings, and the values of other saved configurations.

The menu level column shows a menu option's hierarchy level from the top menu. Number 1 indicates the top menu, and the largest number is the menu that is the furthest down the menu tree.

All Settings View

In the All Settings View mode, all menus and its corresponding values display in a table. The menus with values different from the Factory configuration is highlighted in purple and the value itself is highlighted in yellow. See Figure 66.

Menu Name	Menu Level	Factory	Manufacturing	Floor 1	Floor 2
Currency Sign	5	RMB Select	RMB Select	RMB Select	RMB Select
AR3240 Compat.	5	Disable	Disable	Disable	Disable
CPI/LPI Select	3				
Select CPI	4	10.0 CPI	12.0 CPI	13.3 CPI	20.0 CPI
Select LPI	4	6.0 LPI	6.0 LPI	6.0 LPI	8.0 LPI
DBCS CPI	4	6.7 CPI	6.7 CPI	5.0 CPI	6.7 CPI
Host Command	3	Ignore Unidir.	Ignore Unidir.	Ignore Unidir.	Ignore Unidir.
Font Attributes	3				
Typeface	4	Near LQ	Near LQ	Near LQ	Near LQ
Styling Type	4	SONG	SONG	SONG	SONG
High Density	4	Disable	Disable	Disable	Disable
Prop. Spacing	4	Disable	Disable	Disable	Disable
Bold Print	4	Disable	Disable	Disable	Disable
Italic Print	4	Disable	Disable	Disable	Disable

Figure 66 All Settings View

Differences Only View

In the Differences Only View mode, only the differences between the Factory configuration and other menu configurations are listed. The differing values are highlighted in yellow. The menus are not highlighted.

Menu Name	Menu Level	Factory	Manufacturing	Floor 1	Floor 2
Protect Configs.	1				
HOST INTERFACE	1	Auto Switching	Centronics	Serial	IEEE 1284
EMULATION	1				
Select CPI	4	10.0 CPI	12.0 CPI	13.3 CPI	20.0 CPI
Select LPI	4	6.0 LPI	6.0 LPI	6.0 LPI	8.0 LPI
DBCS CPI	4	6.7 CPI	6.7 CPI	5.0 CPI	6.7 CPI
Funct. of Lines n lines	5	66	66	66	88
Function of CPI n characters	5	136	163	181	272
PRINTER CONTROL	1				
ADVANCED USER	1				

Figure 67 Differences Only view

Displayed Language

The Displayed Language drop-down menu shows all available foreign languages that the attached printer supports. Since this depends on the printer, the drop-down menu will be disabled when the Factory Settings Differences application is first launched. After the Upload Differences program is executed, the available language names supported by the printer will display.

After you select a language, the program determines if it has already been uploaded, and changes the table settings to this language. If it is not loaded, the program uploads the selected language and redisplay the table settings in the new language.

Flash File Manager

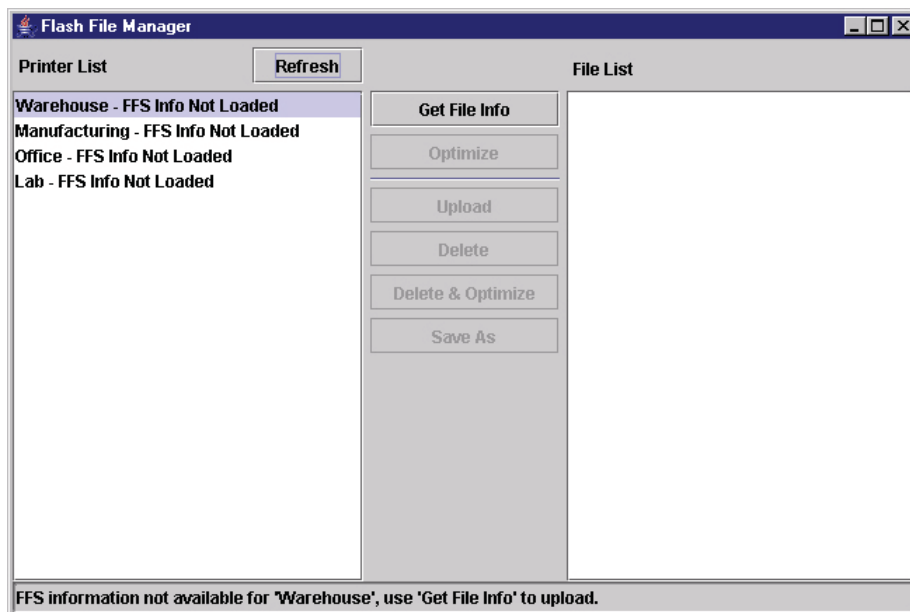



Figure 68 Flash File Manager Window

With the Flash File Manager, you can view a list of the unprotected files loaded in the printer's flash memory and optional EM (External Memory).

NOTE: The EM is available only for SL4M/T4M and P8000 printers.

You can upload the files to the host computer, save them for backup, delete them, and download them to another printer.

Select **Applications ► Flash File Manager** or click the  (flash file manager) button. See Figure 68.

The Printer List pane displays a list of printers that are selected in the printer database. If you select one printer, it appears alone in the list. If you select a folder, all active printers in the folder appear.

If you return to the printer database and select another printer or folder, click **Refresh** to update the Flash File Manager and display the newly selected printer(s).

NOTE: Cloned printers or different folders that link to the same printer do not display. Only the original printer displays.

Get File Info

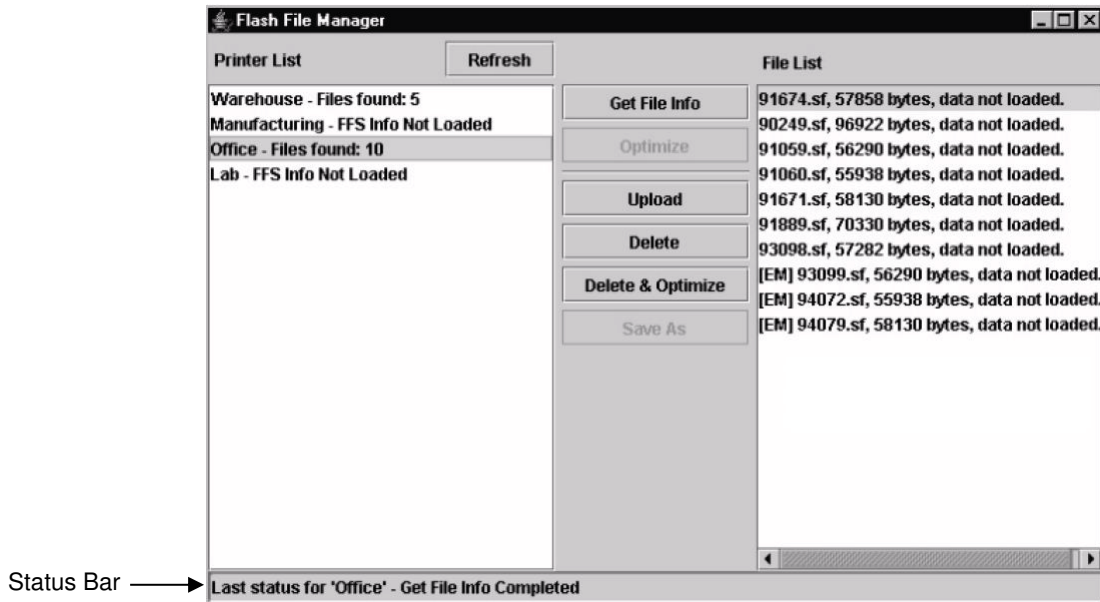

Figure 69 Get File Info

Select a printer, and then click **Get File Info** to see a list of the unprotected files loaded in the printer's flash memory. Progress displays in the status bar at the bottom of the window. After you retrieve the flash memory information, the files appear in the File List pane. See Figure 69.

NOTE: The files are located on the printer's internal flash memory. If [EM] precedes the file name, then the file is located on the optional EM.

When complete, select another printer and click **Get File Info** to view its flash memory information.

You can only view the flash memory information from one printer at a time, but the Flash File Manager remembers what information has been retrieved. For printers that have not had flash memory information loaded, the message FFS (Flash File System) Info Not Loaded displays in the Printer List. See Figure 69.

NOTE: Although you have retrieved the flash memory information, the files have not been uploaded. Notice the message "data not loaded" in the File List. To upload the files, see Upload on page 79.

The status bar will toggle from the status of the last operation performed to the status of the printer flash: memory available (free), memory used (in use), and memory deleted but not optimized (trashed):

Last status for 'Office' - Get File Info Completed

Printer Flash info for 'Office' - free 1469kb, in use 2346kb, trashed 0b

If you have an EM installed, the status bar will also toggle the status of the EM:

EMC info for 'Office' - free 32223kb, in use 304kb, trashed 0b

Upload

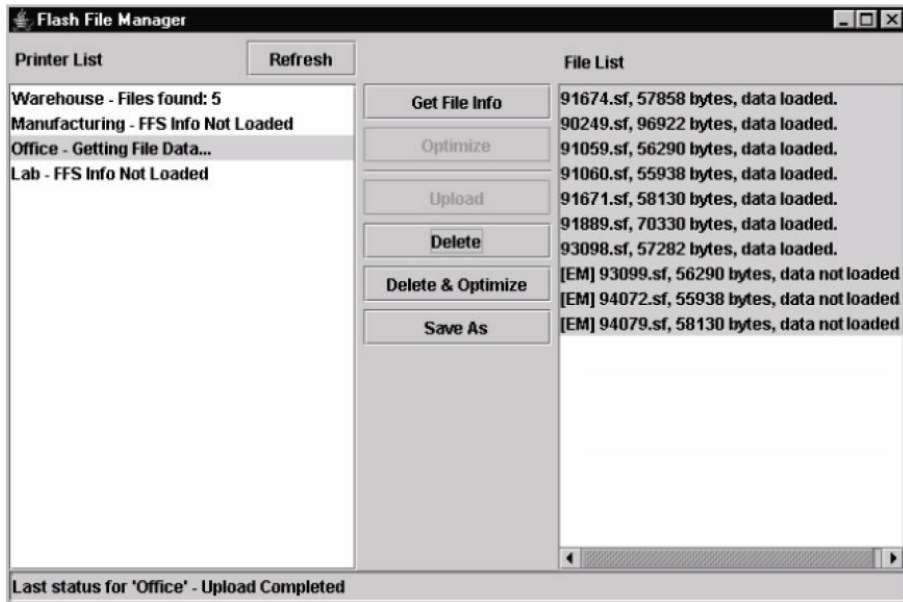

Figure 70 Uploaded Flash Files

To upload unprotected files, select a printer, and then select the files you want to upload from the File List. Click **Upload** to upload the unprotected files from the flash memory. Progress displays on the status bar at the bottom of the window.

After the files upload, they appear selected in the File List pane. See Figure 70. Click **Save As** to save all the files together as one downloadable file (bundle file). Save the file with a **.pff** file extension.

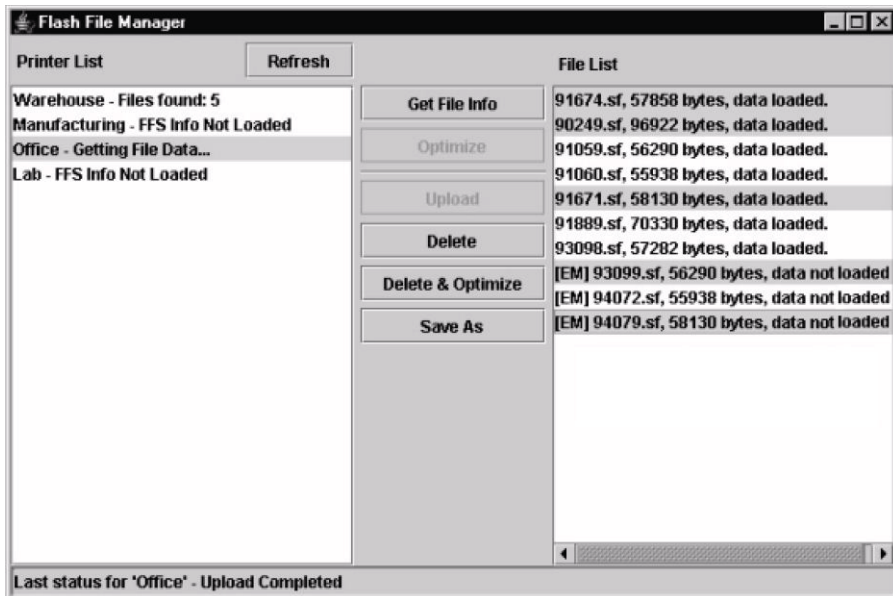

Figure 71 Selecting Multiple Files

Or, you may use the **Shift** or **Ctrl** key to select single or multiple files. See Figure 71. This way, only the selected files will save to the **.pff** file when you click **Save As**.

NOTE: You can save only uploaded files to a downloadable file.

Delete And Optimize

IMPORTANT You can not undo a flash file deletion.

You can erase files from the printer's flash memory. Select the files you want to delete from the File List, then click **Delete**. To download files back to the flash memory, see File Download on page 80.

Once you have deleted files, the flash memory is not optimized until you click **Optimize**. Optimizing reclaims flash space from deleted flash files.

NOTE: The printer reboots after you Optimize.

To delete and optimize in one step, select the files you want to delete from the File List, then click **Delete & Optimize**.

CST Manager

See Datastream Adapter on page 133.





File Download

NOTE: The terms **download** and **upload** as used here and in the software indicate the printer's point of view. Therefore, when you download a file, you are sending information to the printer (the printer downloads). When you upload a file, you are receiving information from the printer (the printer uploads).

IMPORTANT To utilize the File Download application, make sure **Enable Status Monitoring** is checked in the **Polling** tab (see page 46). Then select your printer in the printer database and click the  update status button to make sure your printer has been polled at least once (see page 50).

The File Download application allows you to download any of the following file types (program files, configuration files, recovery files, and flash files) to either a single printer or to a group of printers in one step. Recovery files are an exception and should only be downloaded back to the printer that had problems during a download.

To download a file to a single printer, insert a  (Download file) icon below the printer (one level lower than the printer). To download a file to a group of printers, insert the Download file icon on the same level as the printers (in the same folder containing the printers). Use the printer database and insert additional Download file icons to download as many files to as many printers as you want.

NOTE: Previous versions of PNE Auto ID required different file types to be downloaded to the printer in separate steps, which is why the various file types were identified by  or  icons. With this version of the software, a distinction between the various file types is not needed, and a  icon identifies all file types. Therefore, if you open a printer database that was saved using a previous version of the software, all  icons will change to 

Define the Download Files

After you insert Download files, you must define them:

1. Double-click  **New Download File**. The Define Download File dialog box opens. See Figure 72.

2. Click **Browse**. The Open dialog box opens.

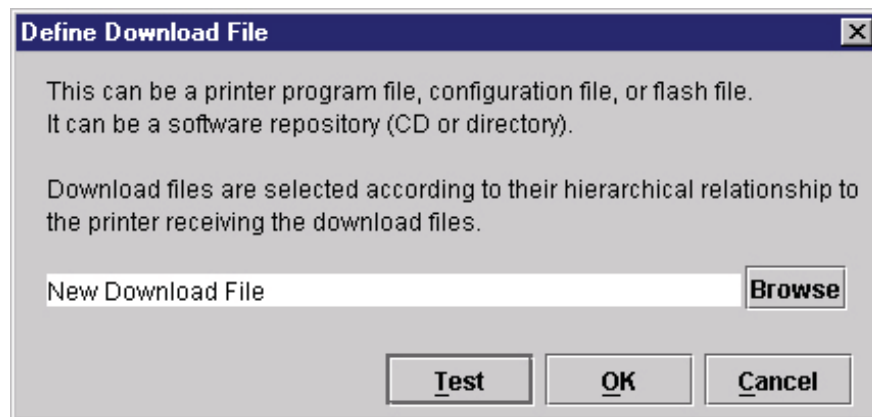



Figure 72 Define Download File

3. Navigate to a program (firmware), configuration, recovery file, or flash file, select it, then click **Open**.
4. Since multiple file types can now be downloaded in one operation, a **Test** button is provided to allow you to verify if the file type specified is supported by the printer. Clicking the **Test** button causes PNE Auto ID to evaluate the specified file and display the file type – this will help you verify that you selected the correct file. Click **OK** if the file type returned is correct, click **Cancel** to terminate, or click **Browse** to select another file.
5. When you are finished, click **OK**. The database displays the path and name of the program, configuration, recovery or flash file.

Download the Files

After you define Download files in your database, you must download them to your printer for them to affect the active print state.

NOTE: Each emulation used by the printer has its own list of valid flash files it can use. Refer to the appropriate *Programmer's Reference Manual* for details about valid flash files.

To begin the download process, select a printer or a folder containing printers and select **Applications ► File Download**, or click the  (file download) icon. The File Download dialog box opens and displays a list of all the printers that you selected in the printer database. See Figure 73.

NOTE: If you later select a different printer or folder in the printer database and the File Download dialog box is still open, click **Update List** to update the list of printers.

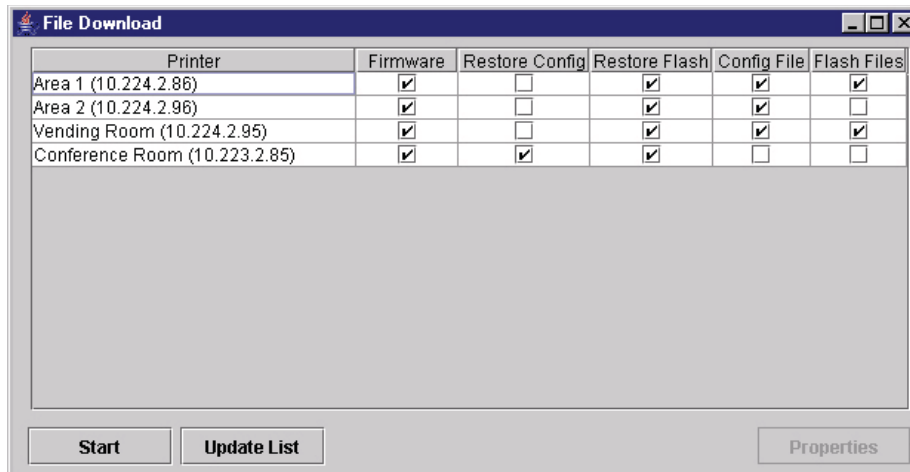

Figure 73 File Download

The following are the download options for each printer:

Firmware: Check this box to download the printer firmware (program file).

Restore Config: Check this box to restore the configurations that were in the printer once the Program File download has been completed.

Restore Flash: Check this box to restore the flash files that were in the printer before the Program File was downloaded.

Config File: Check this box to download a new configuration file.

Flash Files: Check this box to download additional flash files.

For each printer listed, various combinations of these operations can be executed. Some combinations are mutually exclusive. For example, PNE Auto ID does not allow you to simultaneously preserve the printer's configurations and download a new configuration file to the same printer (you cannot check both Restore Config and Config File for the same printer). Similarly, you cannot restore configurations or flash files unless you are downloading new program files.

NOTE: You can double-click a field name (e.g., Firmware, Config File, etc.) to check or uncheck the check boxes for all displayed printers at once.

Printer's SD card: Using PNE Auto ID to download files to the printer SD card may take a while. To avoid printer network connection time outs, change the printer print job timeout setting to indefinite. The printer print job timeout is different from the "Network Time Out" described in Network Sub-Tab on page 30.

To change the printer print job timeout, telnet to the printer and type 'store pserver opts jobtimeout 0' and 'reset'.

Viewing the File Destination

Select a printer in the File Download dialog box and click **Properties**. The Update Properties dialog box opens. See Figure 74.

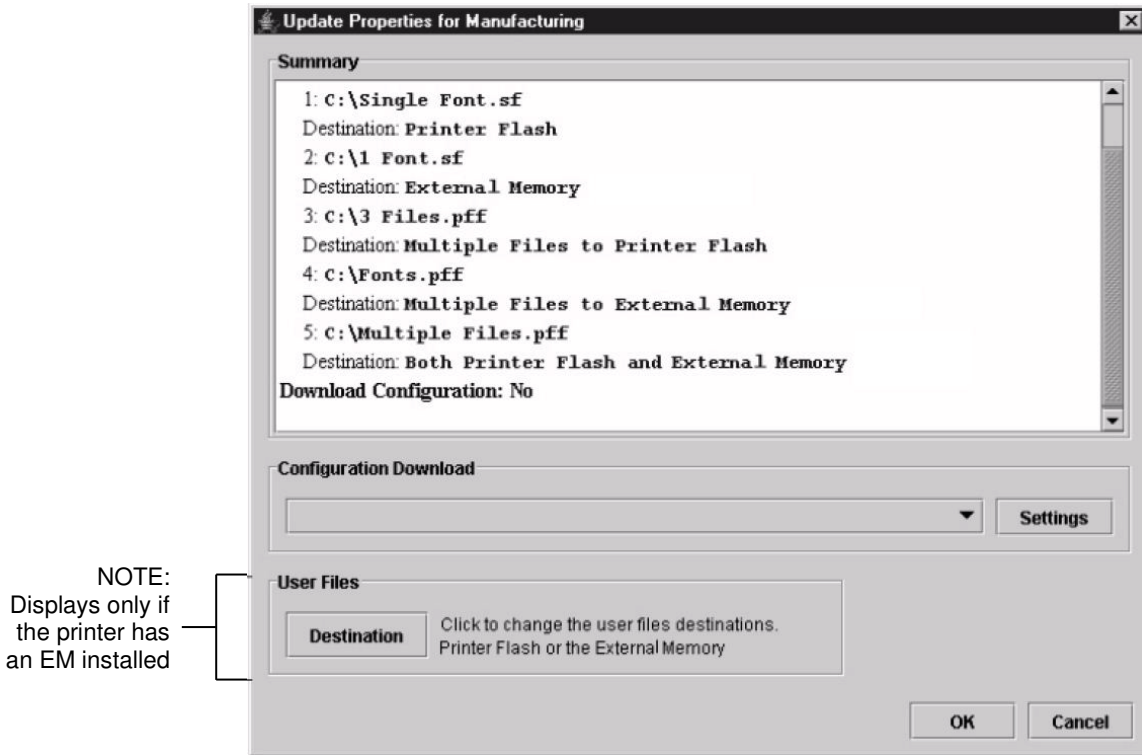

Figure 74 Update Properties

The Update Properties dialog box lists all the files that will be downloaded to the selected printer, the source of the files, and their destinations: Printer Flash (a single file to the printer’s flash memory) or Multiple Files to Printer Flash. Also, if the printer supports the EM: External Memory (a single file to the EM), Multiple Files to External Memory, or Both Printer Flash and External Memory.

IMPORTANT PNE Auto ID can only download files to the EM through the NIC.

Changing the File Destination

If you have the optional EM and you wish to change the destination of a single file, click **Destination**. The User Files dialog box opens. See Figure 75.

Select **Printer Flash** or **EM** to specify the new destination.

NOTE: Bundle files (archives that contain multiple files, usually with a .pff extension) cannot have their destinations changed. Files within bundle files will download to the printer’s flash memory, the EM, or both, depending on their original location.

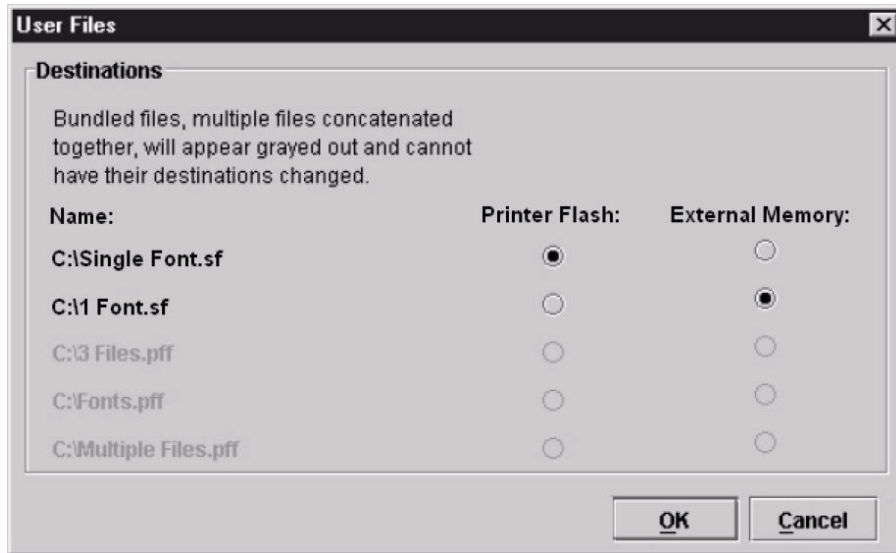

Figure 75 User Files

Restoring Configurations and Flash Files

Whenever a printer downloads a program (firmware) file, the configurations and flash memory are erased. You can choose whether or not to restore the configurations and/or flash memory to what was previously loaded. Check or uncheck the Restore Config check box for configurations and/or the Restore Flash check box for flash files. By default, the configurations and flash memory will restore.

IMPORTANT If you uncheck Restore Config or Restore Flash, the configurations or flash memory will erase when you initiate a program file download.

NOTE: If a download fails due to a power interrupt or a severed connection, the configurations and flash files will be lost and will not restore. You can still restore the printer using the recovery file, but only if Restore Config and/or Restore Flash was checked. See Recovery File on page 89.

If you are downloading a program file and flash files, the Flash Files and Restore Flash check boxes will be checked. The flash files will restore, but they will be overwritten if the new flash files you are downloading have the same name.

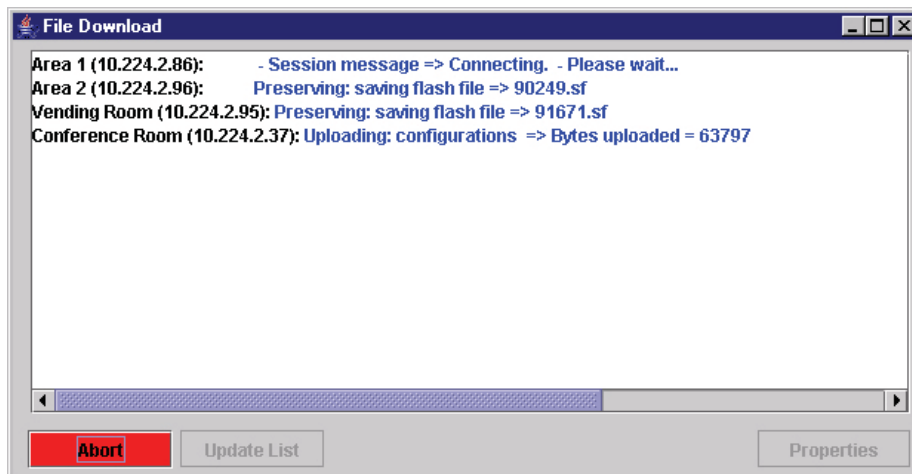

Figure 76 Download in Progress

Confirm that the correct files will be sent to the appropriate printers. Close the dialog box to cancel the download and start over.

Click **Start** to begin the download. Once the download is in progress, click **Abort** or close the dialog box to abort the download. See Figure 76.

IMPORTANT **Aborting a download may leave the printer in an unstable state.**

Before any operations begin, PNE Auto ID obtains the printer type from the printer and compares it with the printer type in the firmware file. If the types do not match, PNE Auto ID aborts the operation and shows an error message in the File Download status window.

During the download, the printer's flash memory will be erased, and CLEARING FLASH will display on the operator panel. At this time, PNE Auto ID may appear to stop operating. This is normal, and the entire download process should take no more than fifteen minutes.

NOTE: Be sure to calibrate your thermal printer after you download a configuration to it. See "Running Auto Calibrate" in the printer's *Administrator's Manual*.

You can also download a series of files to several printers at once using folders. Select a folder and select **Applications ► File Download**. All of the appropriate files inside the selected folder download to all of the printers inside that folder.

NOTE: Downloading a configuration file does not immediately update the printer's active configuration. You must activate a downloaded configuration using the Load Config. setting in the operator panel. Refer to the printer's *Administrator's Manual* for details.

See page 85 for examples of using the printer database and the File Download application to download files.

Downloading Examples

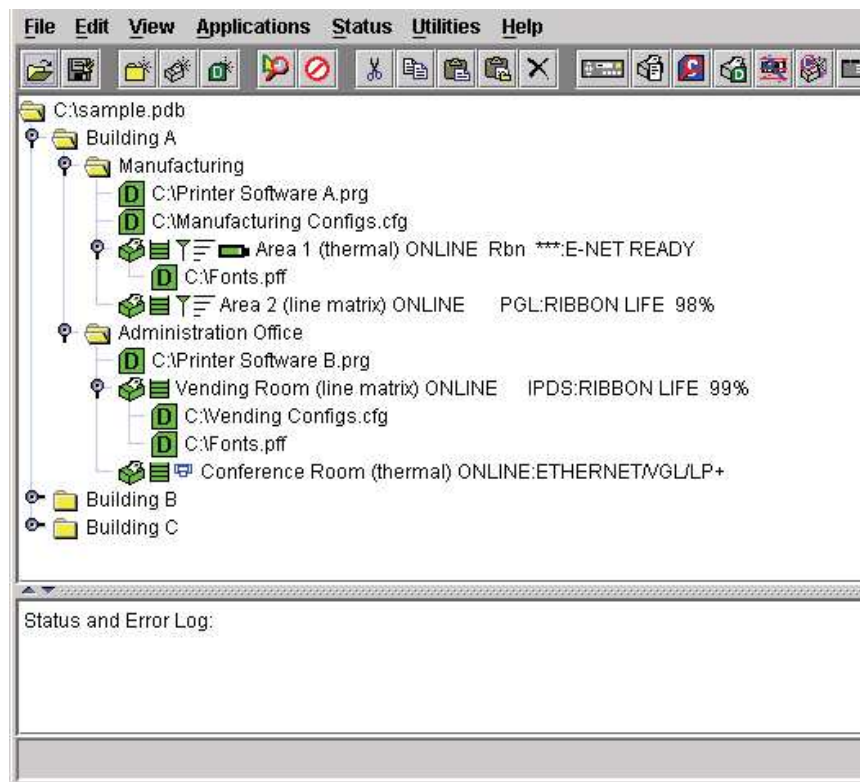

Figure 77 Sample Database

In this sample printer database (Figure 77), the printers are organized according to different parts of the building. Each area contains its own printers and Download files.

In the Manufacturing folder, two printers share the same program and configuration Download files, the Area 1 printer has a flash Download file (in this example, a fonts file), and the Area 2 printer has no flash Download file.

In the Administration Office folder, two printers share a program Download file, the Vending Room printer has a configuration and a flash Download file, and the Conference Room printer has no configuration or flash Download file.

The Building B and Building C folders are collapsed.

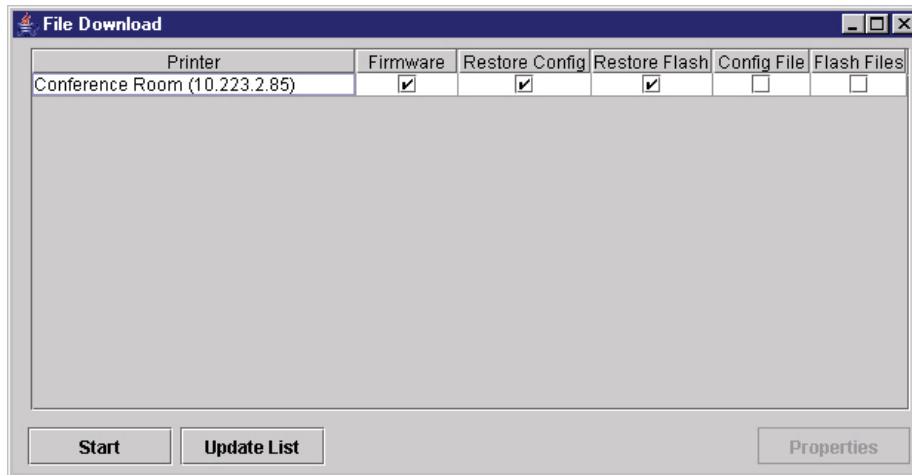



Figure 78 File Download: Conference Room Printer

Example 1

In this example, the user selected the Conference Room printer, then selected **Applications ► File Download** or clicked the  (file download) button. The File Download dialog box opens. See Figure 78.

The Conference Room printer will download a program (firmware) file, and the configurations and flash memory will restore

IMPORTANT If you uncheck **Restore Config** or **Restore Flash**, the configurations or flash memory will erase when you initiate a program file download.

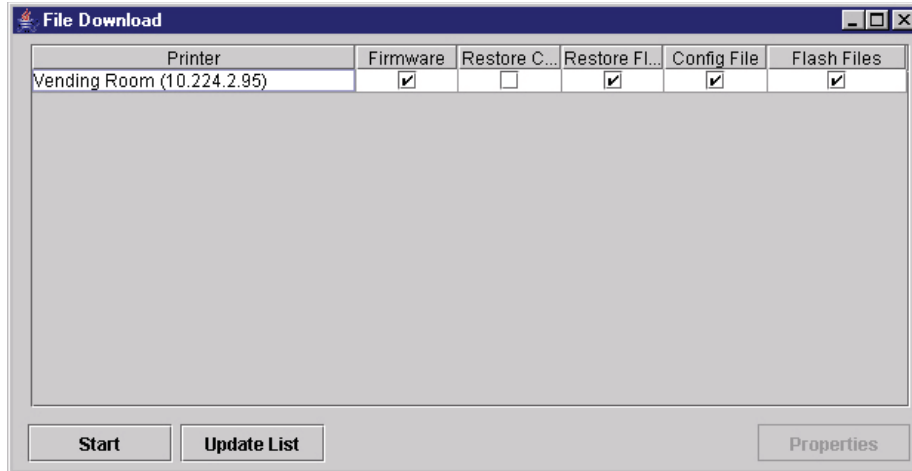



Figure 79 File Download: Vending Room Printer

Example 2

In this example, the user selected the Vending Room printer, then selected **Applications ► File Download** or clicked the  (file download) button. The File Download dialog box opens. See Figure 79.

The Vending Room printer will download a program (firmware), configuration, and flash file, and the flash memory will be restored.

To see a summary of the files the printer will download, double-click the printer or select the printer and click **Properties**.

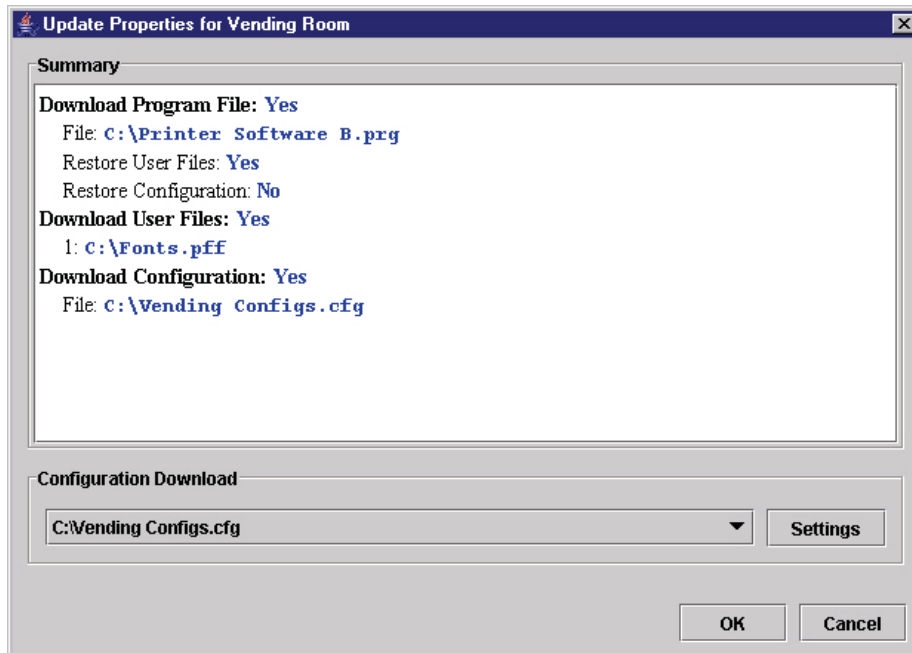

Figure 80 Update Properties for the Vending Room Printer

The update Properties dialog box opens. See Figure 80.

In this example, the Vending Room printer will download the Printer Software B.prg program file, the Vending Configs.cfg configuration file, and the Fonts.pff flash file.

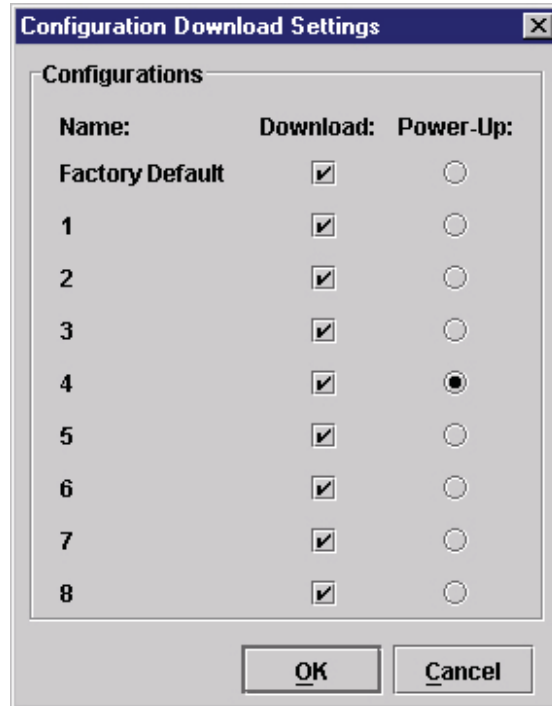

Figure 81 Configuration Download Settings

Since the printer will download a configuration file, you can click **Settings** to open the Configuration Download Settings dialog box. See Figure 81.

You can select or deselect specific configurations within the configuration file you want to download. Only the selected configurations will download. You can also select which of the configurations will be set as the Power-Up configuration.

In this example, the printer will download all configurations, and the Power-Up configuration will be set to configuration 4.

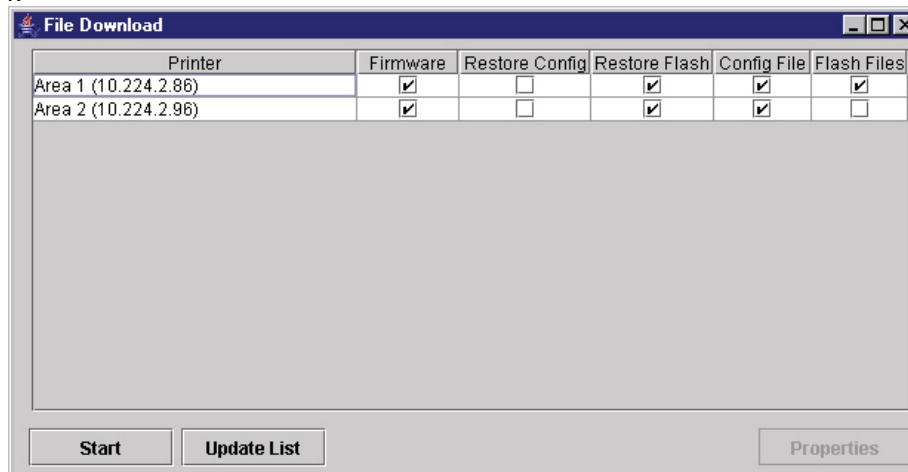



Figure 82 File Download: Manufacturing

Example 3

In this example, the user selected the Manufacturing folder, then selected **Applications ► File Download** or clicked the  (file download) button. The File Download dialog box opens. See Figure 82.

In this example, the Area 1 and Area 2 printers will download the same program (firmware) file and a configuration file, since both files are in the same folder as the two printers (see Figure 77). In addition, the Area 1 printer will download a flash file.

Both printers will have their flash memories restored.

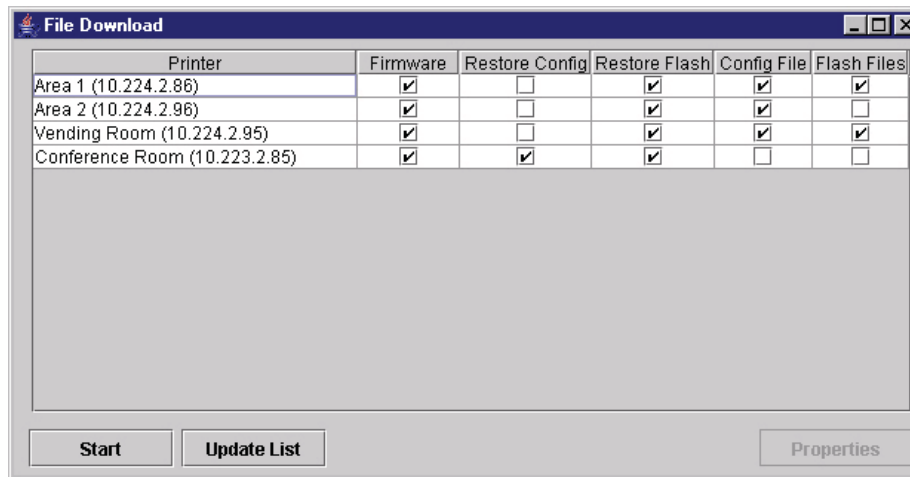



Figure 83 File Download: Building A

Example 4

In this example, the user selected the Building A folder, then selected **Applications ► File Download** or clicked the  (file download) button. The File Download dialog box opens. See Figure 83.

In this example (refer to Figure 77):

- The Area 1 and Area 2 printers will download the same program (firmware) and configuration files, and their flash memories will be restored.
- The Area 1 printer will download a flash file.
- The Vending Room and Conference Room printers will download the same program file.
- The Vending Room printer will download a configuration and a flash file, and its flash memory will be restored.
- The Conference Room printer will not download a flash or configuration file, but its configurations and flash memory will be restored.

IMPORTANT Make sure the same printer is not listed more than once in the File Download dialog box.

Recovery File

Whenever a printer downloads a program (firmware) file, the configurations and flash memory are erased. You can choose to restore the configurations and/or flash memory, but if during the download the power interrupts or the connection severs, the files will be lost and will not restore.

PNE Auto ID makes a recovery file of the configurations and flash memory before they are erased. The recovery file is located in the PNE Auto ID installation directory.

If a download fails, the Status and Error Log will display the location of the recovery file. The file is named after the printer name in the printer database, followed by a **.par** extension (printer archive).

Add a download file under the printer that failed during the download process. Open the Define Download File dialog. Click the browse button and navigate to the location of the recovery file. The recovery file is displayed in the Status and Error Log. Click OK to define the download file.

IMPORTANT **It is necessary that a program file be used with your recovery file. Make sure that you add a program file under the printer in the database or enable it if it is disabled.**

Click the printer to download and open the File Download application. Click Start to download the recovered files and settings to the printer.

NOTE: The properties and the download settings cannot be changed when you are using a recovery file. Recovery files are not deleted by the File Download application once an error occurs. This file should be deleted once the printer has the recovered configuration settings and flash files.

The **.par** archive contains the configuration file, which is named after the name of the printer in the printer database. The archive also contains the flash files, which are named exactly as they appeared in the flash memory.

GPIO Manager

See GPIO Manager on page 181.

Media Profiler

The Media Profiler application is only available for thermal printers. It provides a means to analyze media sensing problems. You can use it on labels that are difficult to profile using the standard printer profiling method. If necessary, you can capture, document, and send this information to professional service centers for further analysis.

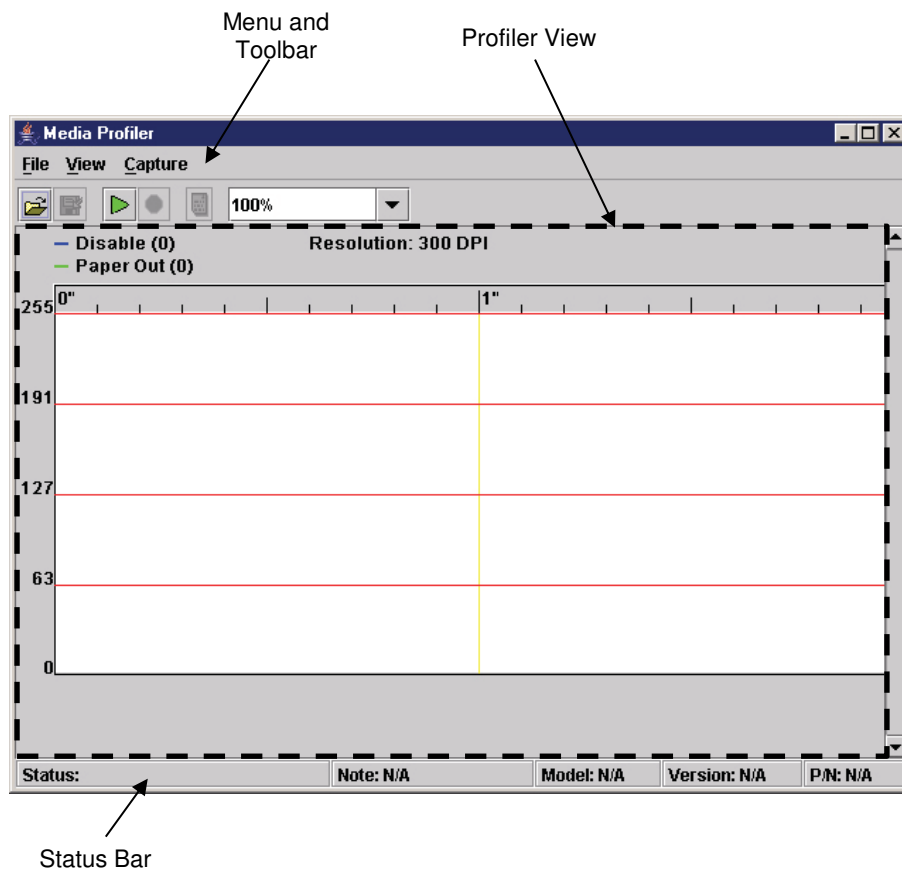



Figure 84 Media Profiler Window

To access the Media Profiler application, select **Applications ► Media Profiler** or click the  (media profiler) button. The Media Profiler will open with no profiler data loaded or captured. It is divided into four sections, the menu bar, toolbar, profiler view (which contains the profiler graphic), and status bar. See Figure 84.

The Menu And Toolbar

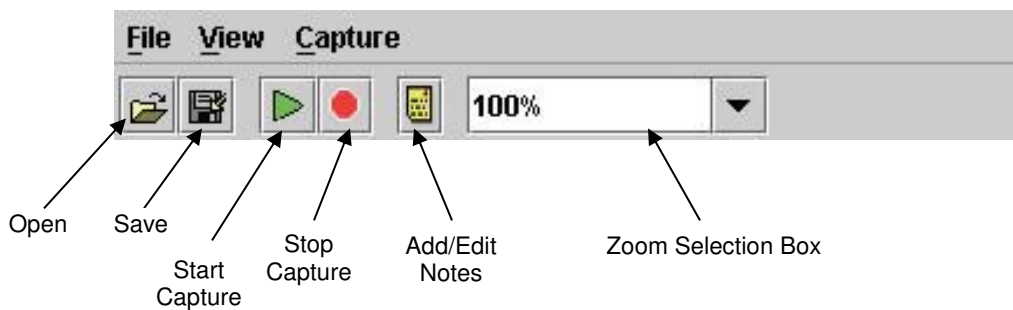

Figure 85 Media Profiler Menu and Toolbar

File

Open: Opens a dialog wherein the user can select a previously saved file that contains profiler data. Media profiler files use the **.mpd** extension (Media Profiler Data).

Save/Save As: Saves captured data to disk for later reference or for use in another program. The file will save with the **.mpd** extension by default.

Notes: To add notes to captured data. Since the first line of the notes will display in the status bar (see The Status Bar on page 97), use short and distinct information that will be included in screen captures.

Exit: Exits the Media Profiler application. You will be warned if any data needs to be saved.

View

Show Crosshair: When this menu item is checked (the default), a crosshair will display when the mouse pointer is hovering above the profiler graphic (see Figure 87 on page 93).

Clear: This will clear the profile view. The user will be informed if the captured data has not been saved.

Capture

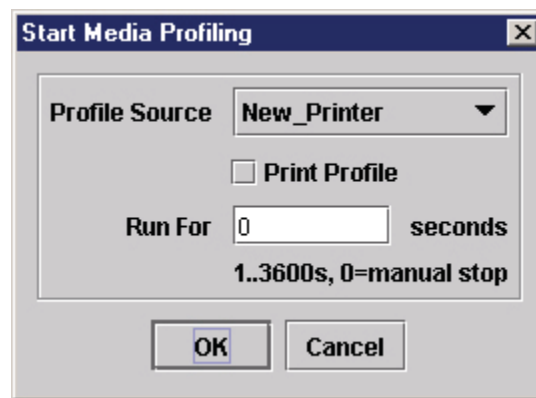

Figure 86 The Start Media Profiling Dialog Box

Start: Opens the Start Media Profile dialog box. See Figure 86.

From the Profile Source drop-down menu, you can choose an available printer from the printer database. This is the source for the media profile test.

If you check the Print Profile checkbox, the profiler data will also print on the installed media. The Run For value determines how long the profiler test will run. If you select **0** seconds (the default), the test will run until you stop the capture (click the stop capture button, press F6, or select **Capture ► Stop**).

NOTE: You can always stop a capture before a specified time elapses.

After you click **OK**, the Media Profiler will attempt to establish a connection with the selected printer. If a connection is established, it will check if the printer supports capturing the media profiler data. If it does, the profiler test will start. The profiler test will run until the specified time has elapsed or until you stop the capture.

Stop: This action is enabled while a profiler test is running. If selected, it will stop the currently running profiler test.

Profiler View

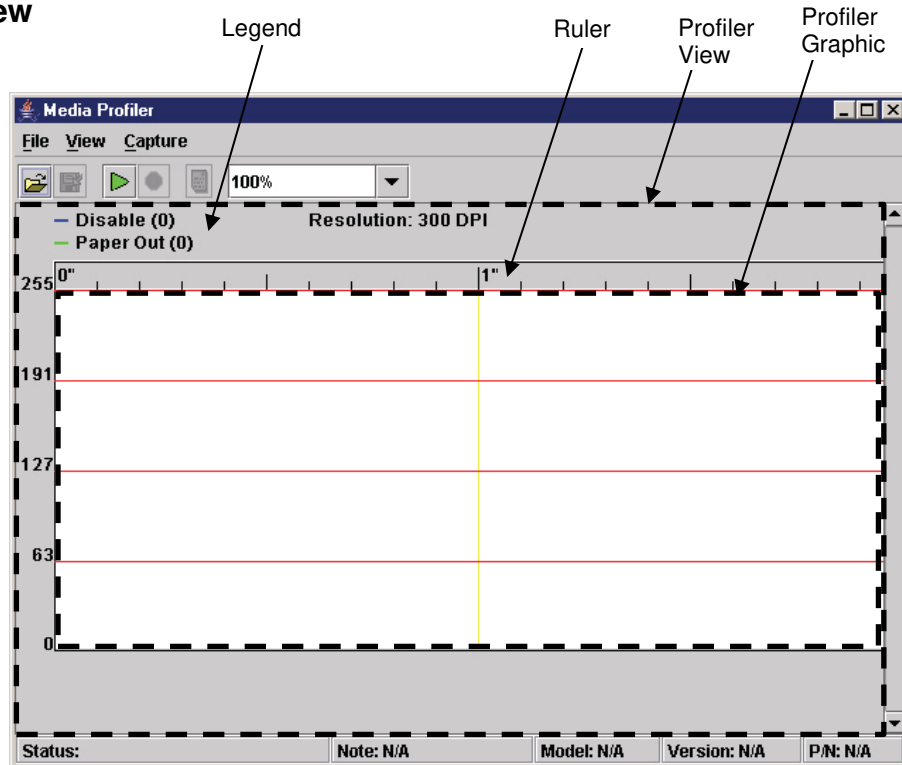

Figure 87 Profiler View

The center part of the Media Profiler window is the profiler view. The profiler view is divided into three sections: the legend, ruler, and profile graphic. See Figure 87.

Legend

The legend displays the current values for two thresholds: Sensor Type and Paper Out. These values are set to zero by default since no threshold values have been received. These values are updated when the capture starts.

Sensor Type can be one of the following: Disabled, Mark, Gap, Advanced Gap, or Advanced Notch. By default it is set to Disabled. When dynamic sensing is enabled on the printer, the value of Sensor Type is Dynamic.

The Ruler

The ruler displays the length of the captured profile in inches. The ruler has small ticks every tenth of an inch, and a larger tick every half inch. A resolution of 300 DPI is used by default to determine the length. When the profile capture starts the actual DPI will be retrieved from the printer and the ruler will update to reflect the correct DPI.

Profile Graphic

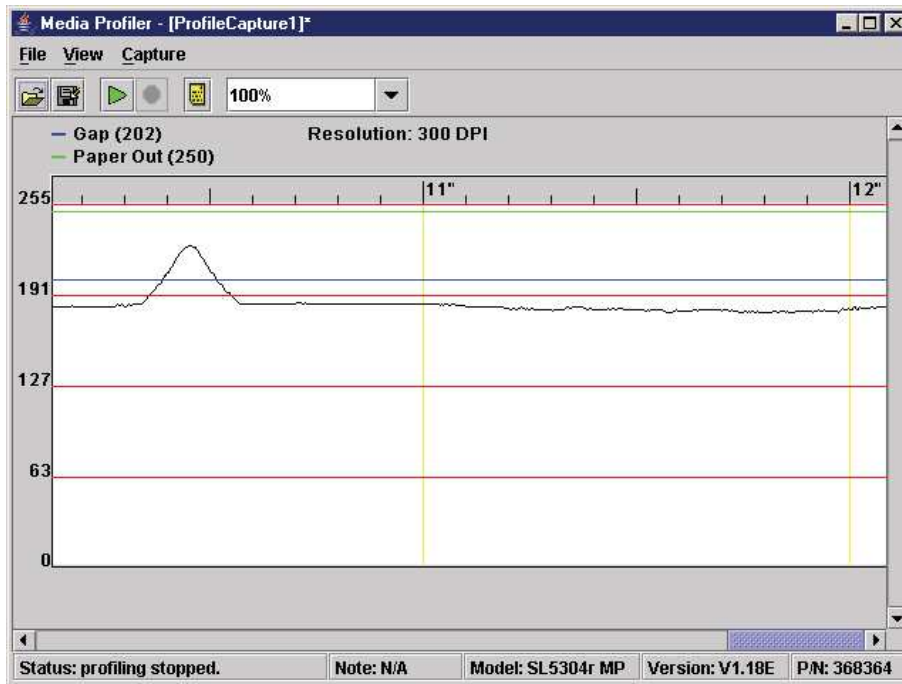

Figure 88 Profiler Graphic

The profile graphic has four horizontal divider lines to indicate the quarter values of the sample data. When the capture starts, the samples of the profiler data will display on the graph.

The printer will send out the profiler sample data on regular intervals and the profiler view will be updated automatically. If the profiler graph is too wide to be shown in one window, a scroll bar will appear to be able to scroll the graph.

The printer sends out one sample for each dot, so 300 samples per inch will be received for a 300 DPI printer. During the capture, the view will auto scroll to show the last captured profiler data until the specified time has elapsed or you stop the capture. See Figure 88.

When the profiler test starts, the printer will send out the current threshold values. The thresholds are indicated by colored horizontal lines on the profiler graphic: blue for the Sensor Type threshold and green for the Paper Out threshold. If dynamic sensing is enabled on the printer, the Sensor Type threshold will be shown dynamically similar to the sample data.

The Crosshair

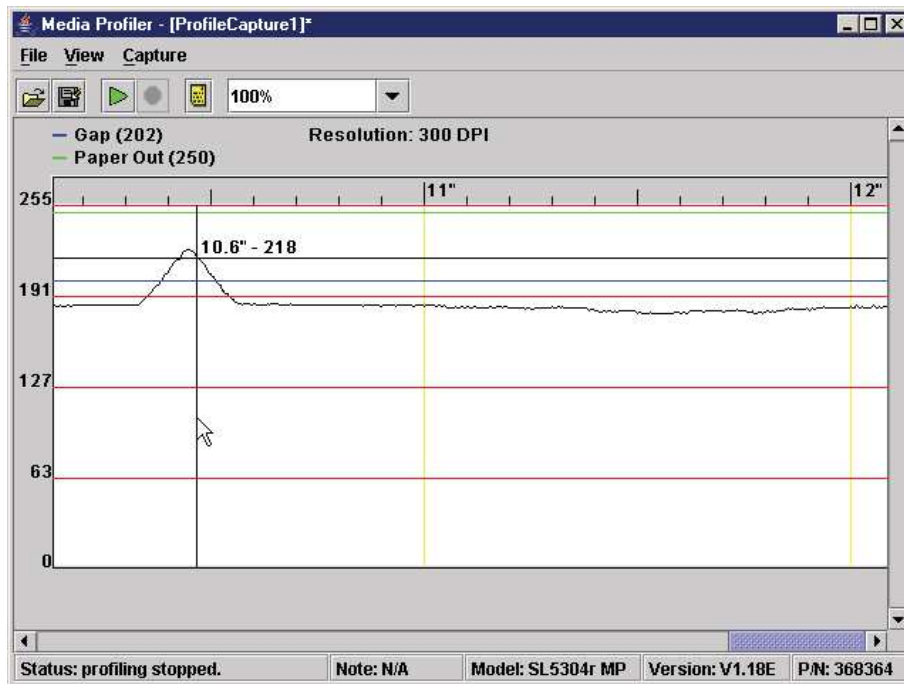

Figure 89 The Crosshair

The crosshair appears when the Show Crosshair menu item is checked (the default). When the pointer hovers above the profiler graphic, a crosshair is shown to indicate the sample value at that location and the distance to the origin. See Figure 89.

Press the **Ctrl** key to change the crosshair into a horizontal line that follows the mouse vertical position. You can use this to determine the optimal sensor values.

NOTE: Set the zoom factor to display the entire graph for this feature. See Zoom on page 96.

Zoom

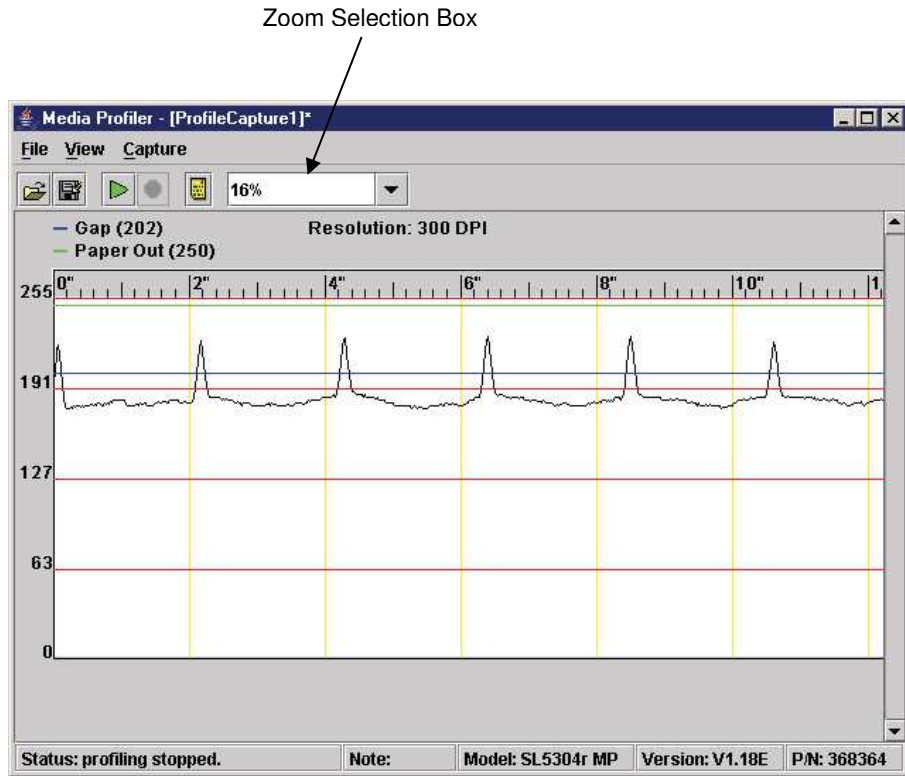

Figure 90 Zooming

You can use the zoom selection box to set the zoom factor. See Figure 90. You can enter a zoom factor or select a predefined zoom factor. The valid range is 5% to 400%.

If you have a mouse with a scroll wheel, the wheel can be used to zoom in and out. The zoom factor in the zoom selection box will update to reflect the current zoom factor.

You can zoom to display the entire graph in on window and determine the maximum and minimum sample values using the crosshair.

Adjust the Origin

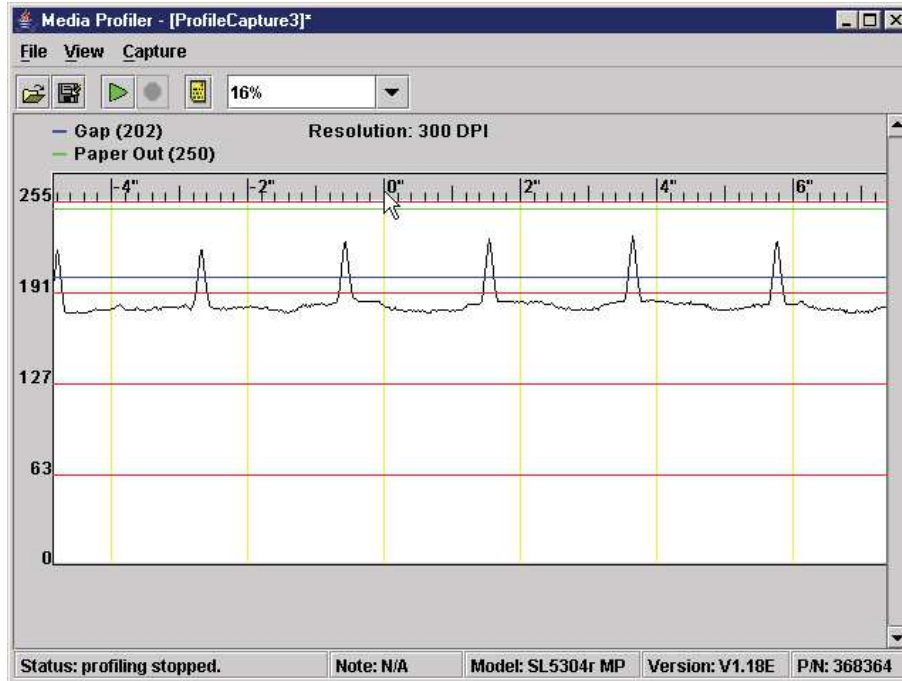

Figure 91 Adjusting the Origin

By default the origin of the graph is located at the first sample of the captured data (leftmost position). You can adjust the origin by clicking on the ruler and dragging the origin to the desired location. See Figure 91.

You can use this to determine the length/slippage of scanned labels in conjunction with the crosshair.

The Status Bar

The status bar is at the bottom of the Media Profiler window (see Figure 84 on page 91.) and is divided into five sections. The first section displays status messages. The second section displays the first line of the notes, if notes were added (see Notes on page 92). The last three sections display the model, version, and part number from the printer being profiled. By default these are set to N/A.

For More Information

Refer to "Running Media Profile" in the *Administrator's Manual*.

Operator Panel

PNE Auto ID includes a virtual operator panel that simulates all the functions of the physical operator panel on your printer. See Table 5 below which lists the different virtual operator panels.

Table 5 Virtual Operator Panels

Figure	Page	Printer
Figure 92	Page 98	SL4M/T4M Thermal
Figure 93	Page 99	SL5000/T5000 Thermal
Figure 94	Page 99	T8000/T6000/T4000/T800 Thermal

The layout of the operator panel changes to visually simulate the printer being used, but the keys and indicators function as described on page 98, regardless of the type of printer used.

The virtual operator panel uploads special font tables from the printer and uses them to match the printer's actual front panel display. If viewing Asian language symbols, the virtual operator panel determines and displays the proper number of lines.

To access the operator panel, select the appropriate printer from the printer database and then select **Applications ► Operator Panel** or click the  (operator panel) button.

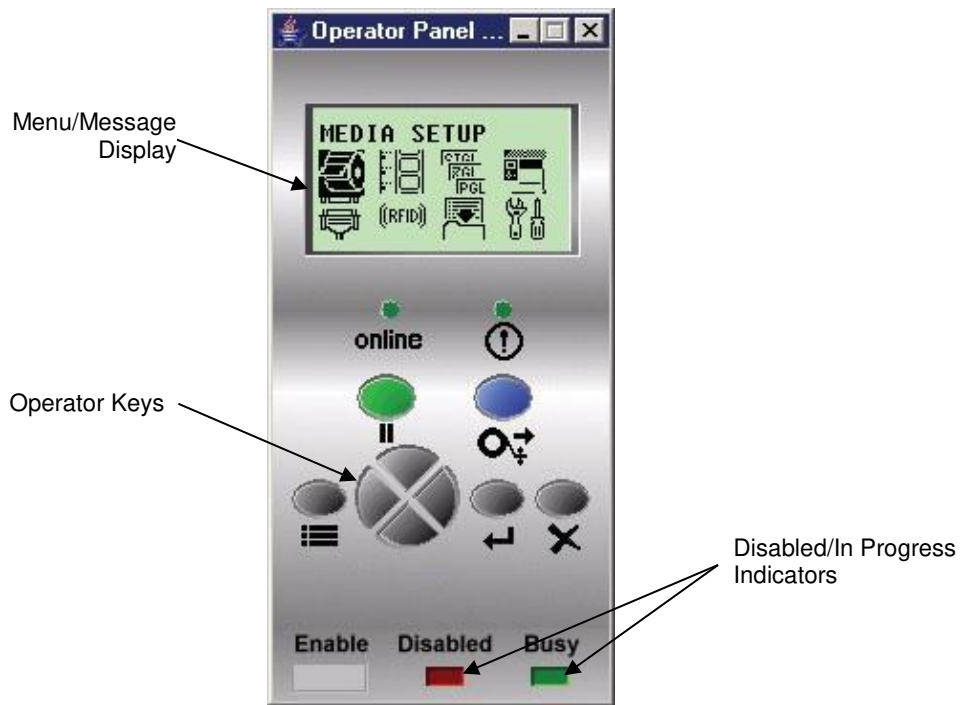

New Figure 92 Thermal Printer Virtual Operator Panel (SL4M/T4M)

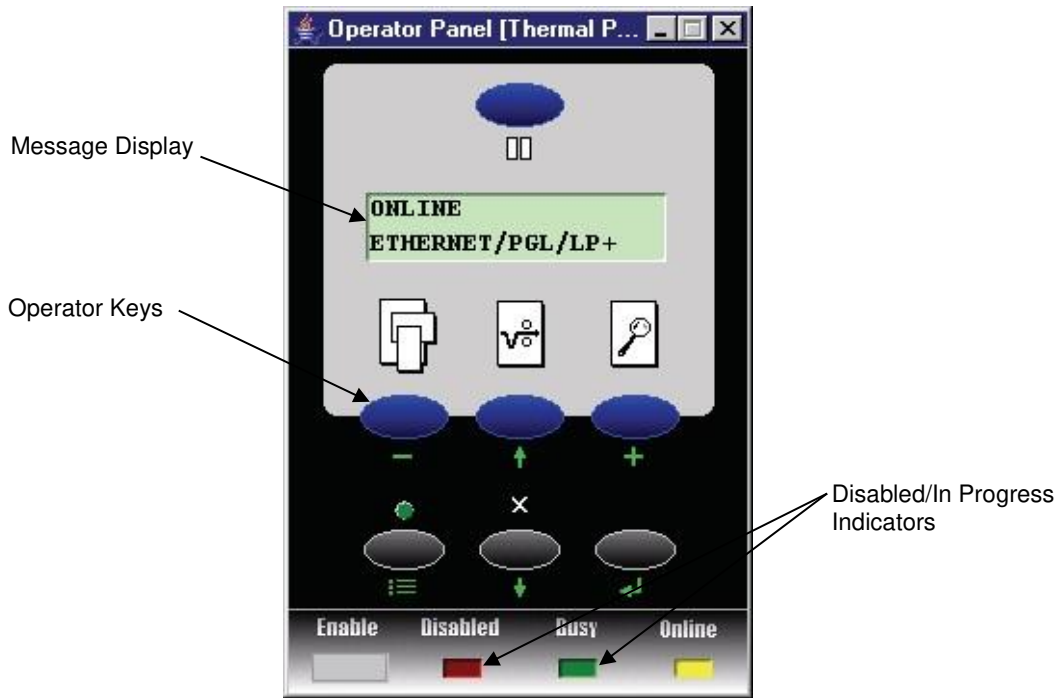

New Figure 93 Thermal Printer Virtual Operator Panel (SL5000/T5000)

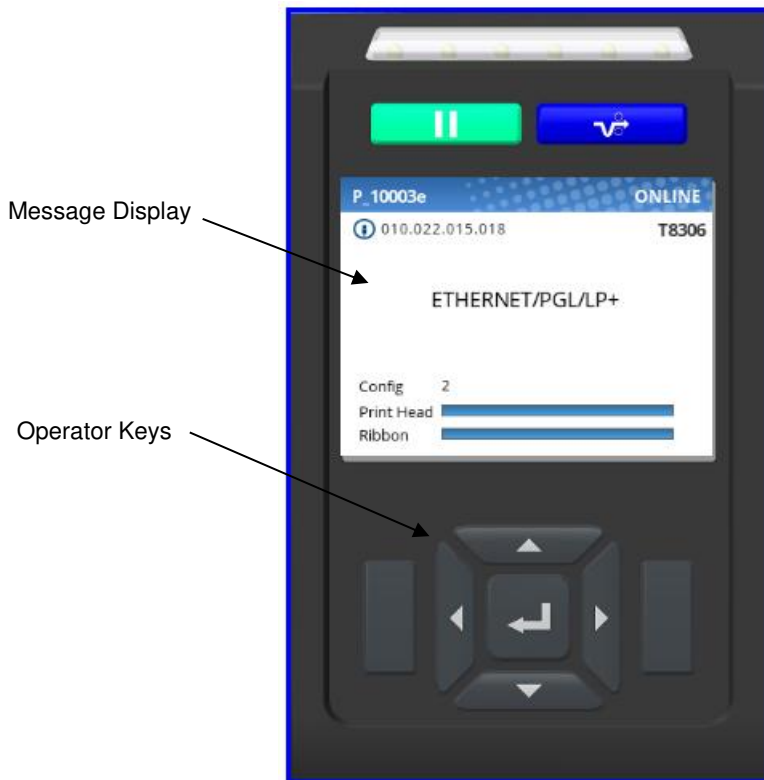

New Figure 94 Thermal Printer Virtual Operator Panel (T8000)

Primary/Secondary Operator Keys

Clicking the primary and secondary operator keys in the operator panel causes the printer to perform the same actions as if you were pressing the keys on the physical operator panel. For example, when the printer is online, click the **II (PAUSE)** key to take the printer offline. Click the **ONLINE (or PAUSE)** key again to place the printer back online.

Some functions require pressing multiple keys at the same time. To simulate this, hold down the **Shift** key on your host keyboard as you select each key. The selected keys change color to indicate that they are part of the multiple key press. Release the **Shift** key, and the selected keys on the operator panel activate as if they were pressed simultaneously.

For example, to unlock the ENTER (↵) key, hold down the **Shift** key on your keyboard, then click Down (↓) and ↵ keys. Release the **Shift** key, and the ENTER (↵) key unlocks.

To perform some functions you must press keys for different lengths of time. For example, on a line matrix printer, in offline mode, pressing and releasing the **PAPER ADVANCE** key quickly on the operator panel performs a line feed; pressing and holding the **PAPER ADVANCE** key for more than a second advances the paper to the next top-of-form. The same is true for the virtual operator panel. Click and release the **PAPER ADVANCE** key quickly to perform a line feed. Click and hold the key down for longer than a second, and the **PAPER ADVANCE** key turns a different color and advances the paper to the next top-of-form.

NOTE: For an explanation of the functions of each primary and secondary operator key, refer to the printer's *Administrator's Manual*.

Message Display

The message display shows what is displayed on the physical operator panel. Use the message display to configure menu options and read error messages.

Status Indicator

The status indicator displays the current operating mode:

Online mode: The indicator displays bright green.

Offline mode: The indicator displays black.

Fault mode: The indicator flashes.

NOTE: The virtual operator panel for the T8000/T6000/T4000/T800 printers does not have any status indicators. Please look at the message display for the current printer status.

Disabled Indicator

Normally, when you control the printer via the operator panel, the Disabled light is off, and the Enable button underneath the status indicator is grayed out. While PNE Auto ID has control of the physical operator panel, the message PRINTER UNDER REMOTE CONTROL appears on the physical operator panel to alert others that the printer is being controlled remotely.

However, if someone presses a key on the printer, the virtual operator panel disables. The Disabled indicator lights up, and the Enable button activates. Click the **Enable** button to give control of the printer back to the virtual operator panel.

NOTE: The virtual operator panel for the T8000/T6000/T4000/T800 printer does not have a disabled indicator. The virtual operator panel and the printer's front panel are active at the same time.

In Progress Indicator

This light flashes when the printer is working on a job or moving paper.

NOTE: The virtual operator panel for the T8000/T6000/T4000/T800 printer does not have a progress indicator.

Information Capture

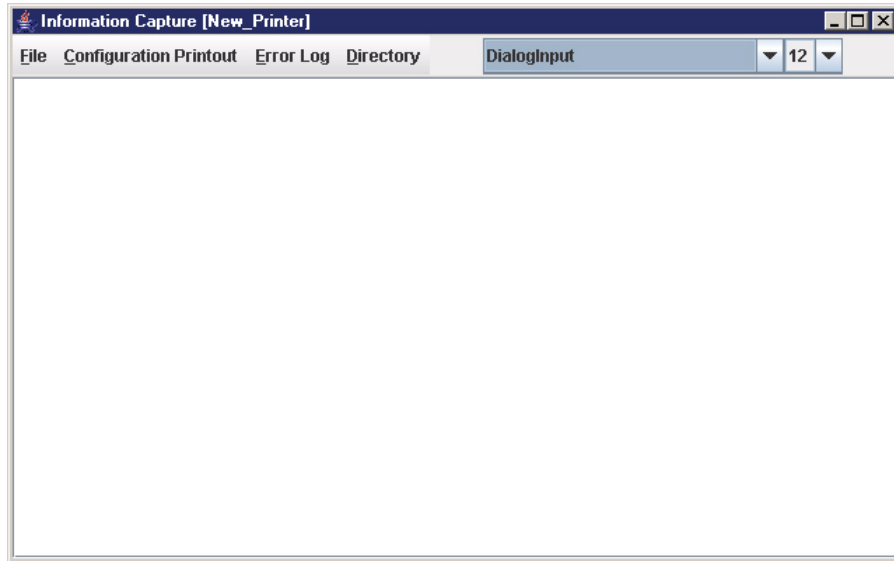



Figure 95 Information Capture Window

To access the Information Capture application, select a printer from the printer database and select **Applications ► Information Capture** or click the  (information capture) button. See Figure 95.

The Information Capture application allows you to view the configurations or error logs saved in the printer's memory and save them as a text file to your local hard drive.

Loading a configuration into the Information Capture does NOT change the active configuration — this is a *view only* application. If you want to change the active configuration, use the Configuration Editor (see page 65) or the operator panel.

The following are descriptions of the Information Capture menus.

File

Save As: Saves the configuration or error log displayed in the Information Capture window as a **.txt** text file on your local hard drive. This **.txt** file can be opened in any word processing program.

Print: Prints the text of the information captured to the host computer's default printer.

Clear Window: Clears the Information Capture window of any displayed configurations or error logs.

Close: Closes the Information Capture window.

Configuration Printout

Current/Factory/Power-Up/All/1-8: Choose which configuration you want to view. If you choose more than one configuration without clearing the window, each additional configuration adds to the end of the display. See Figure 96.

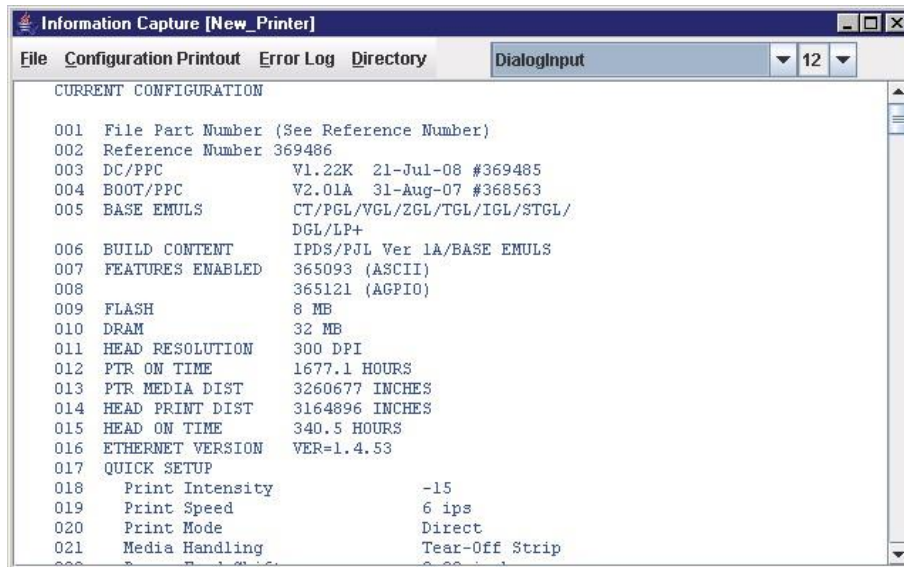

Figure 96 Configuration Printout

Error Log

All Errors: Displays the printer's error log.

Clear: Clears all errors from the printer's memory.

NOTE: The printer's error log and the Status and Error Log at the bottom of the main printer database window of PNE Auto ID are separate. Clearing the printer's error log does not clear the Status and Error Log.

Directory

Flash File System: Displays the file system information for your printer. Includes SD Card/USB.

Validator Report: Captures the validator report for ODV2D if the printer is a T8000.

NOTE: If your printer is equipped with an EM (External Memory), the files will be displayed in two areas: one for the printer's internal flash memory, and one for the EM. See Figure 97.

Information Capture [New_Printer]

File Configuration Printout Error Log Directory

FILE SYSTEM STATISTICS

Printer's Internal Flash Memory

File Name	Size (Bytes)
View Main Files	
93779.sf	177228 Bytes
93952.sf	210124 Bytes
91409.sf	47218 Bytes
90993.sf	47856 Bytes
92250.sf	59792 Bytes
92244.sf	63134 Bytes
92248.sf	59790 Bytes
92500.sf	190512 Bytes
plugin.cdm	122066 Bytes
hq3updt.cdm	53480 Bytes
pluginfp.cdm	206161 Bytes
if.fnt	368 Bytes
hq3.fnt	481 Bytes
uif.ss	21647 Bytes
plugin.ttf	26928 Bytes
utt.ss	15181 Bytes
ptnx4.dvl	174 Bytes
ptnx6.dvl	174 Bytes
ptnx8.dvl	174 Bytes
SMTFILES.ALL	40824 Bytes
EPC203.TIF	1590 Bytes
EPC300.TIF	3226 Bytes
version	47 Bytes
netemb.dat	151 Bytes
ptxLogo.gif	9230 Bytes
Total Bytes In Use By Active Files	1605063
Total Bytes In Use By Deleted Files	0
Total Bytes Available	2302516
View EMC Files	
91059.sf	56290 Bytes
91060.sf	55938 Bytes
91671.sf	58130 Bytes
Total Bytes In Use By Active Files	170358
Total Bytes In Use By Deleted Files	0
Total Bytes Available	16484010

EM

Figure 97 Directory: Printer's Internal Flash Memory and EM

AutoID Data Manager

See AutoID Data Manager on page 249.

ODV Quality Wizard

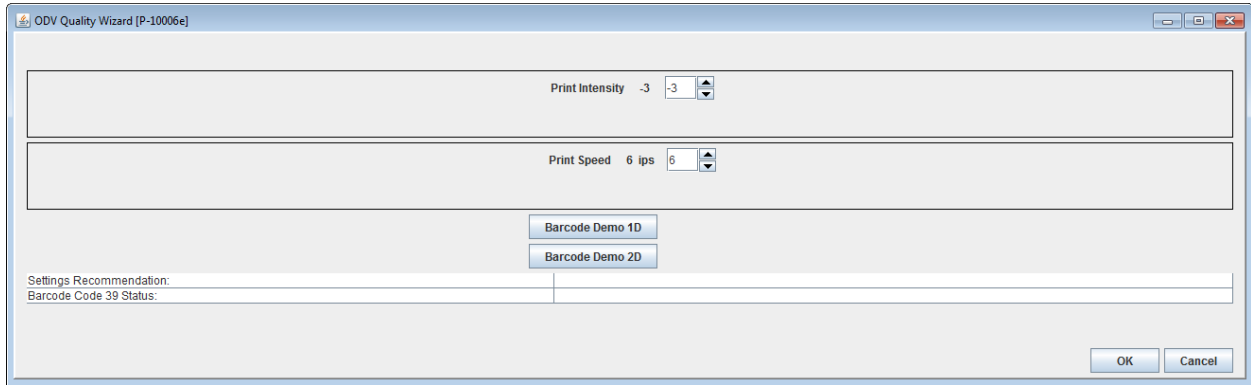

Figure 98 ODV Quality Wizard Window

NOTE: You must set the following in the VALIDATOR menu to use the ODV (online data validator) Quality Wizard:

- Set Telemetry Path to Network Port.
- Set Telemetry Data to Full Report or Validation Mode.

The ODV Quality Wizard is a function that helps you select the best combination of print speed and print intensity that will produce optimal bar code output. It displays controls that allow you to select a print speed and a print intensity.

Click the **Barcode Demo 1D** or **Barcode Demo 2D** button to print and validate a test bar code pattern. Based on the validation results, the ODV Quality Wizard provides setting suggestions to optimize the bar code quality.

IMPORTANT Do not follow any suggestions if “Barcode Code 39 Status” does not display “Pass.”

Click **OK** to save these changes in Configuration 1. Configuration 1 then becomes the Power-Up configuration (see page 65). Click **Cancel** to not save the changes.

IMPORTANT Clicking the  Close button in the upper-right corner functions the same as clicking **OK**.

NOTE: The ODV Quality Wizard is printer specific, and not all printer models have ODV Quality Wizard support. Printers without ODV Quality Wizard support display the error message:

Operation not allowed on this type of printer.

Speed Keys

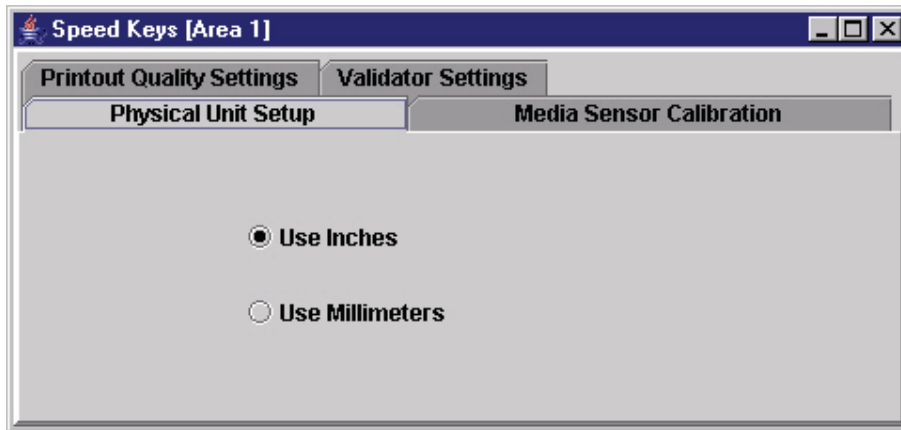



Figure 99 the Speed Keys Window

The Speed Keys are single buttons that allow you to perform a specific operation without having to traverse the operator panel menu structure. The Speed Keys assist you in performing repetitive functions associated with printer configuration or maintenance.

To access Speed Keys, select a printer then select **Applications** √ **Speed Keys** or click the  **Speed Keys** button. See Figure 99.

Changes made using Speed Keys are changed in the printer and saved in Configuration 1. Configuration 1 then becomes the Power-Up configuration (see page 65).

NOTE: Speed Keys are printer specific, and not all printer models have Speed Key support. Printers without Speed Key support display the error message:
Operation not allowed on this type of printer.

The Speed Keys are grouped according to their use:

- Physical Unit Setup
- Media Sensor Calibration
- Printout Quality Settings
- Validator Settings

NOTE: For an explanation of the functions the Speed Keys perform, refer to the printer's *Administrator's Manual*.

Job Capture

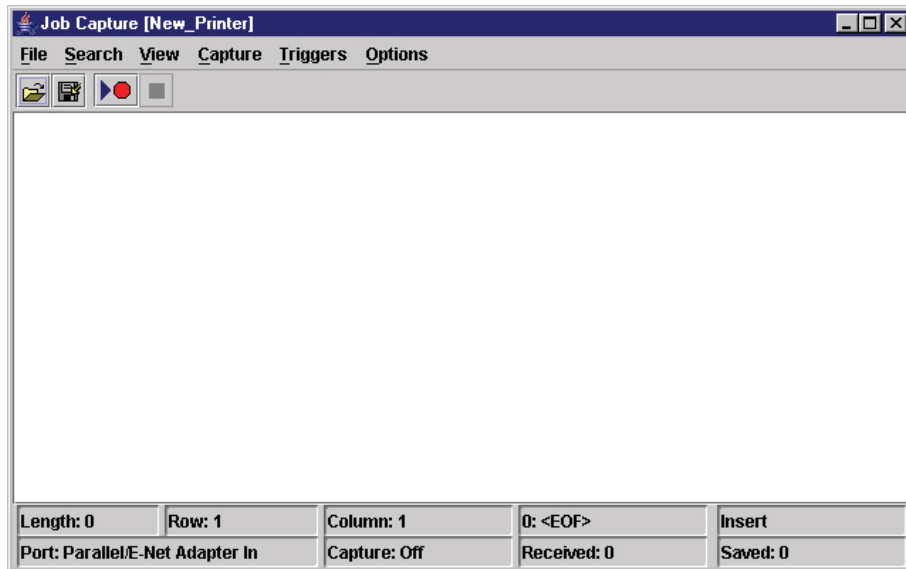



Figure 100 Job Capture Window

Job Capture is an application that captures host datastreams through a specified host interface. This aids in debugging and diagnosing printer errors when working with technical specialists.

To access the Job Capture application, select a printer from the printer database and select **Applications ► Job Capture** or click the  (job capture) button.

Job Capture allows you to capture, modify, analyze, and save information to a file.

To use Job Capture:

1. Be sure the computer running PNE Auto ID is connected to the printer using the diagnostic port. See Printer Setup on page 11.
2. Select **Capture ► Data From** and then select the interface the printer will use to receive the file you want to capture.
3. Select **Capture ► Start** to place PNE Auto ID in capture mode. The interface sends the information to the terminal window until you turn off capture mode.
4. Select **Capture ► Stop** to stop the capture.

The capture window displays the capture information in three formats: Text, Hex, and Capstone. Select **View ► Display Format** to choose the information format. Select **View ► Display Control Codes** to view the control codes embedded in the file.

Once you capture the file and choose the display options, you can save the information to your local hard drive. Select **File ► Save As** and enter a file name. PNE Auto ID saves the captured information as a **.cap** text file. You can open a **.cap** file in any word processing program.

Select **File ► Clear Window** to clear all capture information from the terminal window. Select **File ► Quit** to close the Job Capture application.

Job Capture Features

File

Open

Opens a Job Capture file.

Save/Save As

You can save captured data to disk for later reference or for use in another program. To save the captured data, select **File ► Save** or **File ► Save As**. Data from Twinax sources can be saved in either Hex or Capstone format.

Clear Window

To erase captured data, select **File ► Clear Window**. If you have not already saved the data, a prompt appears and asks if the data should be erased without saving.

Quit

Exits the Job Capture program.

Search

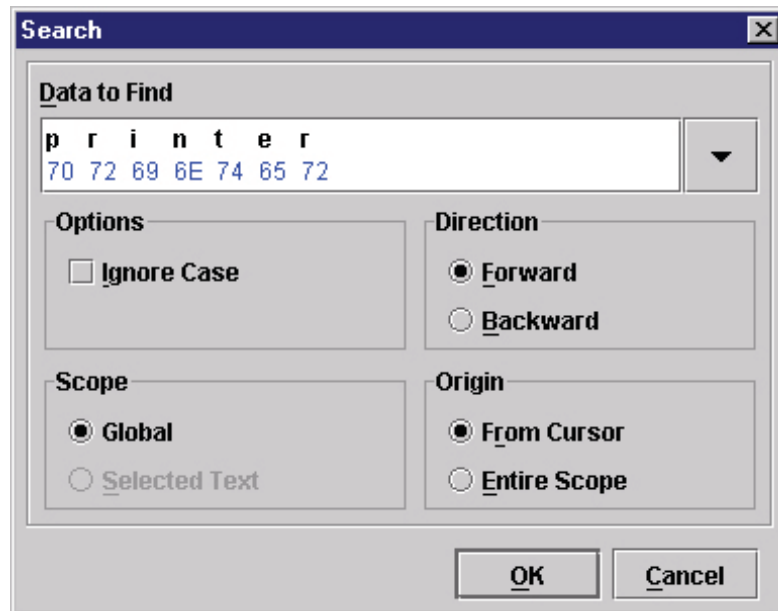

Figure 101 Search Captured Data

Search Captured Data

You can search captured data for specific sequences. Select **Search ► Search Captured Data**. Enter the data as a hex or text string. Click **OK**, and the matching data highlights.

To further refine your search, you can choose whether or not to ignore the case, and specify the direction and origin of the search. If you have text selected, you can also choose whether to search the selected text or all text (Global). Use the down arrow in the upper-right corner to see a history of your searches. See Figure 101.

Search Again

To continue searching, click **Search Again**. A message appears if the search is unsuccessful.

View

Display Format

Data displays in three ways:

- Text
- Hex
- Capstone

Capstone is for Coax/Twinax applications. You can edit Capstone data in Hex mode only.

Display Command Codes

- **Normal:** Codes do not display.
- **Dots:** Dots represent the code.
- **Mnemonics:** Codes display within brackets. For example, Line Feed is <LF>, Carriage Return is <CR>, etc.

Capture

Start

Starts the capture. You can also use the  (start capture) button.

Stop

Stops the capture. You can also use the  (stop capture) button.

Data From

Selects the capture source of data. Options include:

- Parallel/E-Net Adapter In
- Serial In
- Serial Out
- Twinax Host Data
- Coax Host Data
- C/T Base Emulation
- PCI Ethernet In
- USB In

NOTES:

- Serial In and Serial Out ports are not available on the T8000/T6000/T4000/T800 printers.
- Twinax Host Data, Coax Host Data and C/T Base Emulation ports are only available on T5000 printers.

IMPORTANT

If the printer is connected to PNE Auto ID through USB, you cannot perform a job capture or send a print job. USB connectivity can only be used to either manage the printer or print a job. When using the USB for printer management, you can print data using all other interfaces except USB.

Triggers

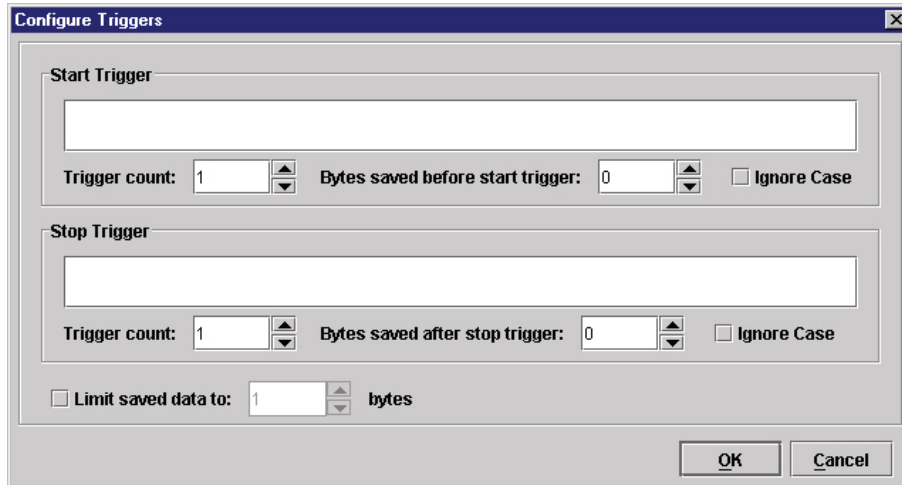

Figure 102 Configure Triggers Window

A Trigger allows a selective capture of host data. You need to specify two triggers, a start trigger and an end trigger. Select **Triggers ► Configure**. See Figure 102.

Enter triggers as text or hex strings with a maximum length of 256 characters. Job Capture scans received data for the start trigger sequence. Once found, data capture begins and continues until Job Capture finds the end trigger.

If you do not set a start trigger, all data is captured when the Job Capture starts. If you do not set an end trigger, the data will continue to capture until you stop it.

A second trigger option is a trigger count. You can set Job Capture to start or stop once it finds a set number of start and/or stop triggers. The window that displays captured data shows any lines containing start triggers and highlights the start trigger strings. You can also use the Search feature to search through captured data.

The Ignore Case check box allows character case to be ignored. Check the box to search for a string regardless of character case, and the data will capture once the string is found.

NOTE: You cannot apply triggers to Coax/Twinax and TCP/IPDS jobs.

Options

Disable Printing

Select **Options ► Disable Printing** to capture data without printing.

Web Access

You can access your printers using a web browser. You can monitor the status, open an operator panel, check the configurations, and access the printer web page.

NOTE: To access your printer using a web browser, you must enable the Web Server and XML Server services (see page 27). Remember to exit and restart PNE Auto ID to enable the service.

The PNE Auto ID Web Site URL Address

Open a web browser. In the URL address field, type `http://`, followed by the host IP address of the workstation running PNE Auto ID or the host name (computer name, not case-sensitive), followed by a colon (:), and then the Web Server port number (see page 27).

For example:

`http://10.224.5.121:8080`

or:

`http://lab21042:8080`

NOTE: Make sure the port number does not conflict with another port number designated for a different purpose.

Press **Enter**, and the web page for your designated printer appears. See Figure 104 on page 110.

To find the host name using Windows, right-click **My Computer** on the desktop and select **Properties**. Click the **Computer Name** (or **Network Identification**) tab, then click **Change** (or **Properties**). The computer name appears in the Computer name field. See Figure 103.

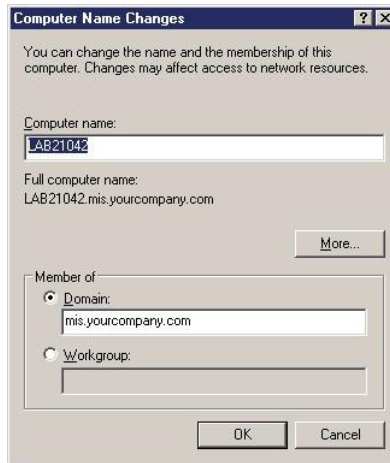

Figure 103 Finding Your Host Name In Windows

Login To The PNE Auto ID Web Site



Figure 104 The PNE Auto ID Web Site

By default, three categories of login privileges are available. See Table 6 for a list of categories and their corresponding user names and passwords.

Table 6 User Login Options

Login Category	User name	Password
Standard	standard	standard
Supervisor	super	super
Administrator	admin	admin

Type **admin** for the user name and password, then click **Login**. The Select Desired Page web page appears. See Figure 105.



Figure 105 The Select Desired Page Web Page

Changing The User Password



Figure 106 The Change Password Web Page

You can change the default password. Click **Change Password Page**, and the Change Password web page appears. See Figure 106.

Enter a new password in the New Password and Retype Password fields, then Click **Change Password**. Your password changes and you return to the Select Desired Page web page.

The Printer List Page

This page will refresh once a minute. Time: 14:33

Sort Printers by

Printer ID	Address	Status	Message	Configuration	Operator Panel	Printer Web Page
Thermal	10.224.1.141	ERROR	Thermal (Building A) PRINT HEAD UP > Close Print Head	Current	Open	Open
Line Matrix	10.22.1.136	OK	Line Matrix (Building B) ONLINE > POWER SAVER MODE	Current	Open	Open

Figure 107 The Printer List Web Page

Click **Printer List Page**. The Printer List web page appears and lists the same printers found in the database pane. See Figure 107.

By default, printers are sorted by Status (Errors). You can also sort printers by Status (Warnings), Status (Online), Address (Ascending), and Address (Descending).

In the above example, the thermal printer displays an error because it is offline. Any printer not ready to print displays an error status.

For an explanation of the Printer List Page options, find the option in Table 7 and follow the corresponding reference.

Table 7 Printer List Page Options

Web Page Option	Reference
Configuration	displays the printer's current configuration
Operator Panel	see page 97
Printer Web Page	opens the NIC Home Page; refer to chapter three of the <i>Network Interface Card User's Manual</i>

NOTE: Administrators and Supervisors can access all five options. Standard users can access only Configuration and Printer Web Page.

Changing User Settings, IP Addresses, and IP Address Ranges

```
<?xml version="1.0" encoding="UTF-8" ?>
<!DOCTYPE ppmXML (View Source for full doctype...)>
- <ppmXML>
- <LoginDatabase>
  <!-- For some user to access the printer information, they need to be
  added by userid. -->
  <!-- The IP address of their machine also needs to be authorized. -->
- <UserDatabase>
  <!-- All the user names, their privilege type (standard, super, admin)
  needs to be added here -->
  <userid password="standard" privilege="standard">standard</userid>
  <userid password="super" privilege="super">super</userid>
  <userid password="admin" privilege="admin">admin</userid>
</UserDatabase>
- <MachineDatabase>
  <!-- Individual address can be included or excluded from accessing the
  printer information. -->
  <!-- ipAddressIncluded and ipAddressExcluded are used for individual
  addresses. -->
  <ipAddressIncluded>10.22.1.121</ipAddressIncluded>
  <ipAddressExcluded>100.100.100.100</ipAddressExcluded>
  <!-- Use ipAddressIncludeRange and its start and end attributes to
  define the access range. -->
  <ipAddressIncludeRange start="00.00.00.00" end="255.255.255.255" />
  <!-- Use ipAddressExcludeRange and its start and end attributes to
  define the invalid access range. -->
  <ipAddressExcludeRange start="00.00.00.00" end="00.00.00.1" />
</MachineDatabase>
</LoginDatabase>
</ppmXML>
```

Figure 108 The PpmLogin.xml File

The PpmLogin.xml file, located in the PNE Auto ID installation directory, contains user settings and the included/excluded IP addresses and IP address ranges. See Figure 108.

To modify this file, open it using a text editor.

IMPORTANT The PpmLogin.xml file should only be modified by expert users. Incorrect entries in this file could render the Web Server service unusable.

User Settings

```

                                     Password      Privilege category      User name
                                     ↓              ↓              ↓
- <UserDatabase>
  <!-- All the user names, their privilege type (standard, super, admin)
  needs to be added here -->
  <userid password="standard" privilege="standard">standard</userid>
  <userid password="super" privilege="super">super</userid>
  <userid password="admin" privilege="admin">admin</userid>
</UserDatabase>
```

Figure 109 User Login Parameters

The user name, password, and privilege category are defined in the <UserDatabase> section of the file. See Figure 109.

Password: Defines the password for the designated user name. When you change the password using the Change Password web page, this information updates.

Privilege Category: Defines the privilege for the designated user name. The available options are: standard, super, and admin.

User name: Defines the user name. You can only change the user name by modifying this attribute.

You can add additional users by duplicating the following line in the <UserDatabase> section:

```
<userid password="standard" privilege="standard"> standard</userid>
```

IP Addresses and IP Address Ranges



Figure 110 Include/Exclude IP Address Options

You can define which IP addresses are available to PNE Auto ID for access. Any IP address not included or defined in the included range will be unavailable to PNE Auto ID. In addition, any IP address excluded or defined in the excluded range will also be unavailable. The included and excluded IP addresses are defined in the `<MachineDatabase>` section of the file. See Figure 110.

Address Included: Defines which IP address to include.

Address Excluded: Defines which IP address to exclude.

Address Include Range: Defines the range of IP addresses to include.

Address Exclude Range: Defines the range of IP addresses to exclude.

You can add additional included/excluded IP addresses or IP address ranges by duplicating the corresponding lines in the `<MachineDatabase>` section:

```
<ipAddressIncluded>10.22.1.121</ipAddressIncluded>
<ipAddressExcluded>100.100.100.100</ipAddressExcluded>
<ipAddressIncludeRange start="00.00.00.00"
end="255.255.255.255"></ipAddressIncludeRange>
<ipAddressExcludeRange start="00.00.00.00"
end="00.00.00.1"></ipAddressExcludeRange>
```

4 Utilities

Reboot Printer

Reboots the selected printer.

Set Printer Password

PNE Auto ID does not allow passwords to change unless the Supervisor password matches the password in the Printer Properties. See Security Tab on page 58.

NOTE: If a password exists but is unknown, you must clear it first. See Set Password on page 13.

To set the printer password in the database:

1. Double-click the printer name. The Printer Properties dialog box opens.
2. Click the **Security** tab.
3. Type the User and Supervisor passwords.
4. Check the **Supervisor Mode** check box.
5. Click **OK**.

To change the printer password:

1. Click the printer name to select it.
2. Select **Utilities ► Set Printer Password**. The Change Password dialog box opens.

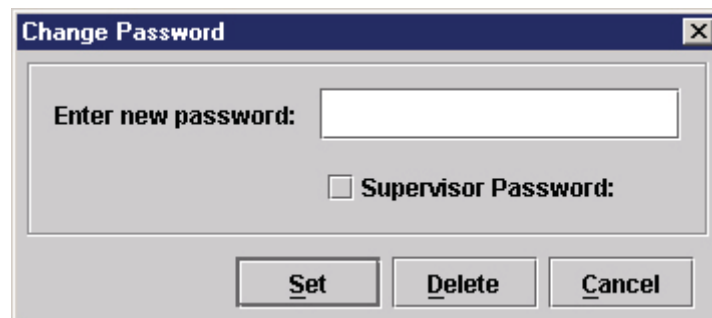

Figure 111 Change Password Dialog Box

3. Type the new password.
4. For a new Supervisor password, check the **Supervisor Password** check box. For a new User password, leave this box unchecked.
5. Click **Set**.
6. If you entered a new Supervisor password, double-click the printer name. The Printer Properties dialog box opens.

7. Click the **Security** tab.
8. Type the same password you entered in step 3 in the Supervisor Password field.
9. Click **OK**.

Set Wireless Properties

NOTE: For a more thorough description of these settings, refer to the *Network Interface Card User's Manual*.

To set wireless properties, select a wireless printer from the printer database then select **Utilities ► Set Wireless Properties**.

The Wireless Properties dialog box contains five tabs: General, WEP Encryption, Kerberos, EAP, and WPA.

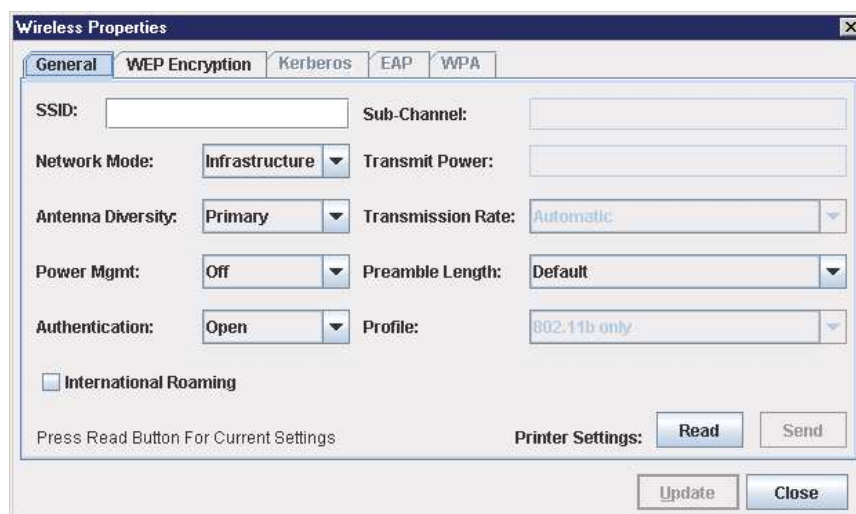

Figure 112 Wireless Properties: General Tab

General Tab

You must click **Read** to obtain the printer's settings before you can modify them.

NOTE: If the NIC has a password assigned to the user **guest**, then a Telnet guest password is required. See Security Tab on page 58.

SSID (Service Set Identifier): A 1 to 32 case sensitive character string that identifies the SS network that the printer with a wireless NIC is a part of.

Network Mode: Determines if the client communicates using an access point (Infrastructure) or other clients peer to peer (Ad Hoc).

Antenna Diversity: The NIC supports a single (Primary and Auxiliary) and dual (Diverse) antenna mode.

Power Saver Mode: Determines if the NIC will go into a power saving mode (Modes 1 through 5) or stay powered up (CAM: Continuous Access Mode).

Authentication: Determines the authentication scheme: Open, Shared, Kerberos, or LEAP.

Open system authentication allows all devices that have the authentication algorithm number for open system to authenticate.

Shared key authentication involves a four step process using secure or encrypted text by means of WEP.

LEAP is to enable LEAP operation.

Kerberos is to enable Kerberos operation.

Sub-Channel: Determines the channel for the radio frequency card: 1 through 15 and Default.

Transmit Power: Determines the wattage of the transmission power: Max (100 mW - Default), 50% (30 mW), 25% (15 mW), 10% (5 mW), and 1% (1 mW).

Transmission Rate: Currently unavailable. Determines the rate of data transmission from the radio frequency card to the access point: 1 MHz, 2MHz, 5 MHz, 11 MHz, and Automatic.

Preamble Length: Determines the size of the packet header generated by the access point: Long, Short, or Default (set by the access point).

Profile: Determines the 802.11g Wireless (Wi-Fi) mode in which to operate. Available modes depend on if the printer is an older printer (T4/T5 Series) or a newer printer (T4/T6/T8/T800 Series).

International Roaming: Check this check box to enable roaming outside the home country.

When you are finished, click **Send** to transmit the values to the printer.

NOTE: If the NIC has a password assigned to the user **root**, then a Telnet root password is required. See Security Tab on page 58.

If you are not going to modify settings on any other tabs, you must update the printer for the settings to take effect. Click **Update** to update the printer.

IMPORTANT Make sure the settings match those configured in the Access Point.

WEP Encryption Tab

The screenshot shows the 'Wireless Properties' dialog box with the 'WEP Encryption' tab selected. The dialog contains the following text and controls:

- General | **WEP Encryption** | Kerberos | EAP | WPA
- For 40 bit encryption (ASCII) use 5 characters
- For 128 bit encryption (ASCII) use 13 characters
- For 40 bit encryption (Hex) use 10 characters
- For 128 bit encryption (Hex) use 26 characters
- Key 1: Key 1 ASCII Hex
- Key 2: Key 2 ASCII Hex
- Key 3: Key 3 ASCII Hex
- Key 4: Key 4 ASCII Hex
- Buttons: Read, Send, Disable, Clear, Update, Close

Figure 113 Wireless Properties: WEP Encryption Tab

You must click **Read** to obtain the printer's settings before you can modify them.

NOTE: If the NIC has a password assigned to the user **guest**, then a Telnet guest password is required. See Security Tab on page 58.

Select which key you want to use for Wireless Equivalency Privacy (WEP) encryption. Use the correct number and type of digits for your preferred encryption strength (40 or 128 bit), then select **ASCII** or **Hex**.

Click **Disable** to disable WEP encryption for the selected printer.

Click **Clear** to clear all keys displayed on the WEP Encryption tab simultaneously. (The keys stored in the NIC are not affected.)

When you are finished, click **Send** to transmit the values to the printer. You can transmit up to four keys at once, but only the selected key will become the active key in the printer.

NOTE: If the NIC has a password assigned to the user **root**, then a Telnet root password is required. See Security Tab on page 58.

NOTE: If the values are not in the selected format, or if the exact number of characters required is not entered, an error message will appear. Correct the problem, then click **Send** again.

If you are not going to modify settings on any other tabs, you must update the printer for the settings to take effect. Click **Update** to update the printer.

IMPORTANT Make sure the settings match those configured in the Access Point.

Kerberos Tab

The Kerberos tab contains four sub-tabs: Print Server, KDC, Set Password, and Credentials.



Figure 114 Wireless Properties: Kerberos Tab - Print Server Sub-Tab

Print Server Sub-Tab

You must click **Read** to obtain the printer's settings before you can modify them.

NOTE: If the NIC has a password assigned to the user **guest**, then a Telnet guest password is required. See Security Tab on page 58.

Status: Displays Authenticated or Not Authenticated once an attempt to send Kerberos information has been sent.

Activate Kerberos: Check this check box to have the printer use Kerberos when the printer is using a wireless connection.

Renewable Lifetime/Units: The maximum allowable renewable lifetime in seconds, hours, or days. The range is 300 seconds to 3 days, or 0 (i.e., no limit). The default is 0.

Print Server Name: The name of the print server.

When you are finished, click **Send** to transmit the values to the printer.

NOTE: If the NIC has a password assigned to the user **root**, then a Telnet root password is required. See Security Tab on page 58.

If you are not going to modify settings on any other tabs, you must update the printer for the settings to take effect. Click **Update** to update the printer.

IMPORTANT Make sure the settings match those configured in the Access Point.

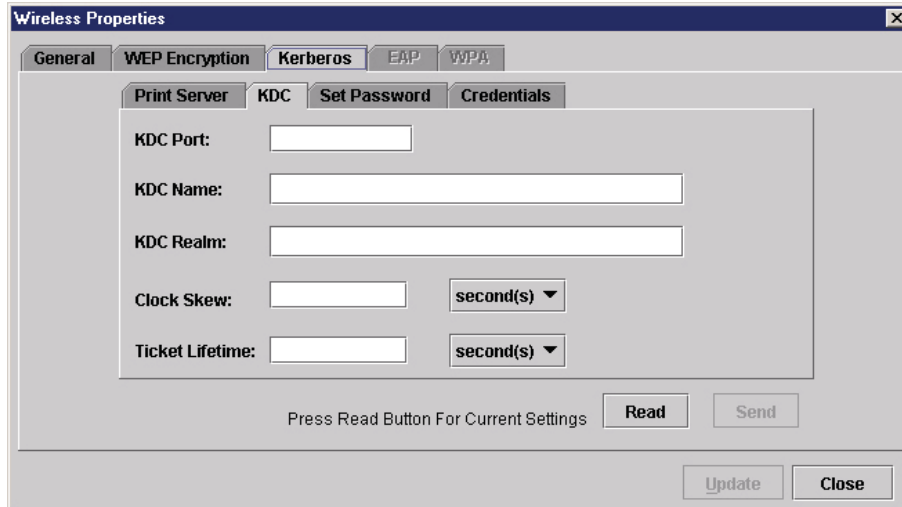

Figure 115 Wireless Properties: Kerberos Tab - KDC Sub-Tab

KDC Sub-Tab

You must click **Read** to obtain the printer's settings before you can modify them.

NOTE: If the NIC has a password assigned to the user **guest**, then a Telnet guest password is required. See Security Tab on page 58.

KDC Port: The TCP/UDP port number used by the KDC. The default is 88.

KDC Name: The name of the KDC which the Access Point is registered. The default is krbtgt.

KDC Realm: The realm of the KDC which the Access Point is registered. The default is **LOCALREALM**.

Clock Skew/Units: The maximum allowable time difference between the Print Server clock and the KDC clock, in seconds, hours, or days. The default is 300 seconds.

Ticket Lifetime/Units: The maximum allowable ticket lifetime in seconds, hours, or days. The range is 300 seconds to 3 days. The default is 10 hours.

When you are finished, click **Send** to transmit the values to the printer.

NOTE: If the NIC has a password assigned to the user **root**, then a Telnet root password is required. See Security Tab on page 58.

If you are not going to modify settings on any other tabs, you must update the printer for the settings to take effect. Click **Update** to update the printer.

IMPORTANT Make sure the settings match those configured in the Access Point.

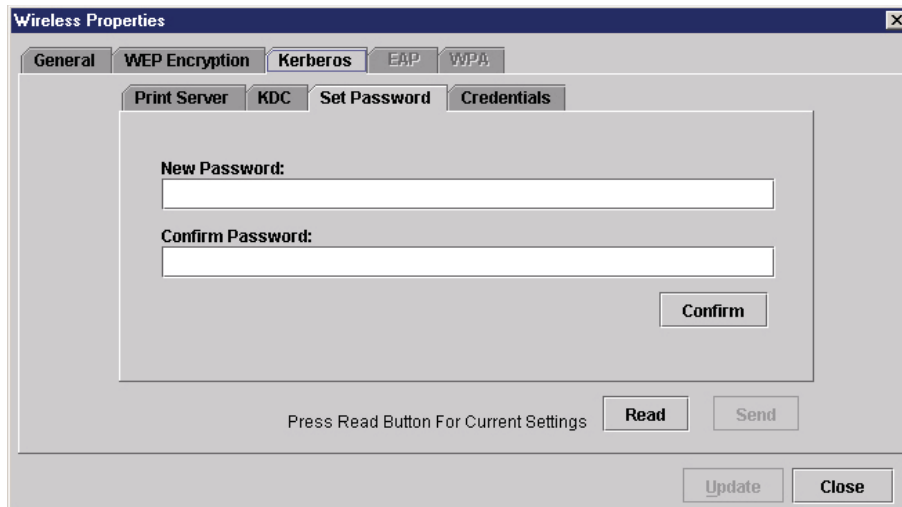

Figure 116 Wireless Properties: Kerberos Tab - Set Password Sub-Tab

Set Password Sub-Tab

You must click **Read** to obtain the printer's settings before you can modify them.

NOTE: If the NIC has a password assigned to the user **guest**, then a Telnet guest password is required.
See Security Tab on page 58.

New Password/Confirm Password: Use these fields to set the Kerberos password. Click **Confirm** to confirm that both the passwords match.

When you are finished, click **Send** to transmit the value to the printer.

NOTE: If the NIC has a password assigned to the user **root**, then a Telnet root password is required.
See Security Tab on page 58.

If you are not going to modify settings on any other tabs, you must update the printer for the settings to take effect. Click **Update** to update the printer.

IMPORTANT Make sure the settings match those configured in the Access Point.

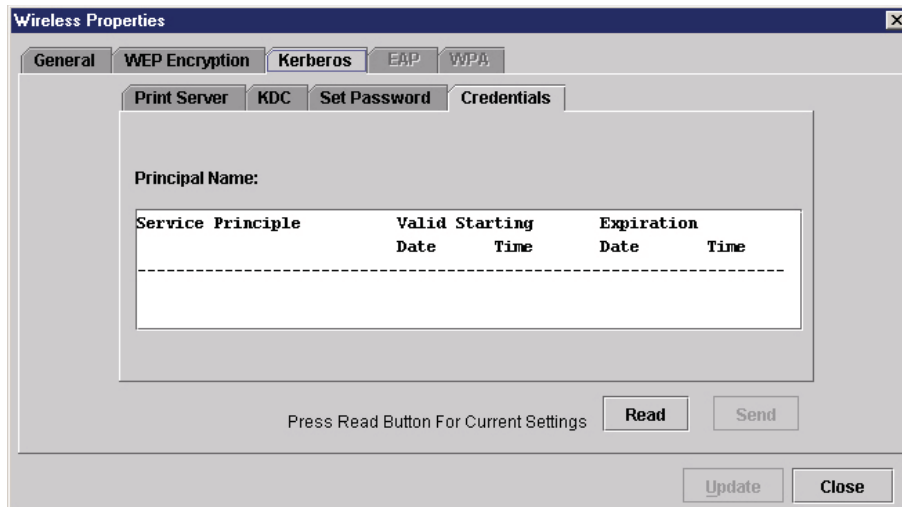

Figure 117 Wireless Properties: Kerberos Tab - Credentials Sub-Tab

Credentials Sub-Tab

This tab displays the Service Principle, the date and time the settings are valid, and the date and time the settings expire.

EAP Tab



Figure 118 Wireless Properties: EAP Tab

You may choose one of three commonly used authentication methods that are supported on the NIC. The methods are PEAP, LEAP, and TTLS.

User Credentials

Enter the User Name, Password, and Confirm Password corresponding to the RADIUS (Remote Authentication Dial-In User Service) server, then click **Confirm** to confirm the Password.

To enable EAP in the NIC, select the **General** tab. Click **Send** to transmit the EAP settings and the wireless properties defined in the General tab.

WPA Tab

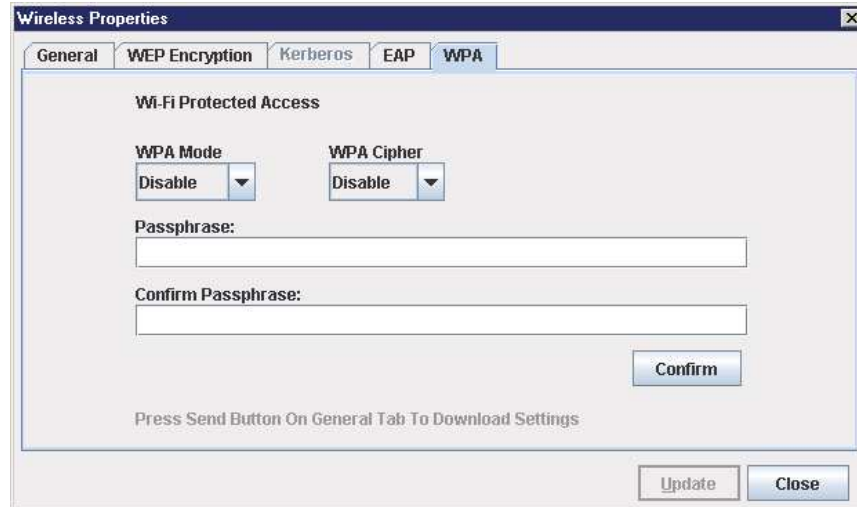

Figure 119 Wireless Properties: WPA Tab

This tab displays the information necessary for the WPA (Wi-Fi Protected Access) wireless security scheme.

WPA Mode: Selects the WPA wireless security mode. By default the mode is set to Disable thus disabling WPA security. If set to Personal, this selects a personal or pre-shared key mode for WPA security.

WPA Cipher: Selects the WPA Cipher wireless security setting.

Passphrase: Sets the individual bytes of the WPA Passphrase.

Refer to the printer's *Administrator's Manual* and the *Network Interface Card User's Manual* for more information.

Macro Utility

The Macro Utility allows you to create a series of ten buttons that will do a range of things such as sending a string of text to the printer to performing functions such as form feeds.

To access the Macro Utility, click the  (macro utility) button at the far right of the toolbar, or select **Utilities ► Macro Utility**. The Macro Utility window opens. See Figure 120.

You can use the File menu options to save and open a set of macros.

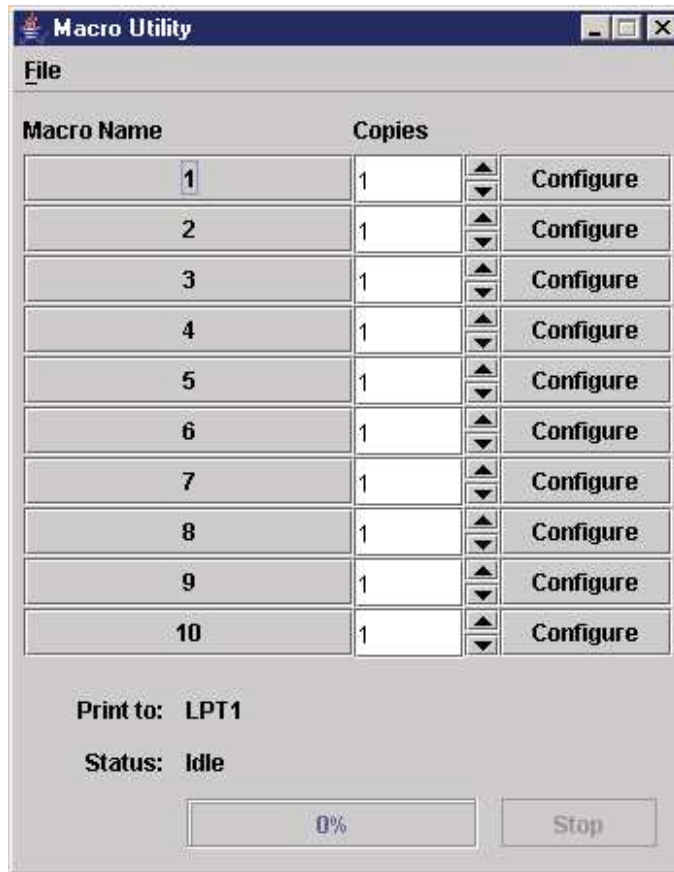

Figure 120 The Macro Utility Window

Configure Macro

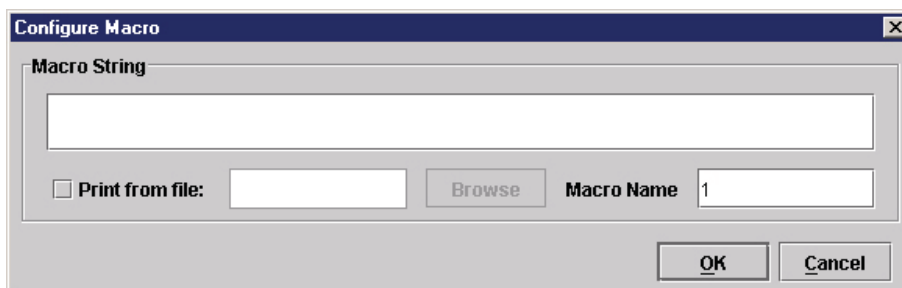

Figure 121 The Configure Macro Dialog Box

To create or edit a macro, click **Configure** to the right of the macro name (initially 1 through 10). The Configure Macro dialog box opens. See Figure 121.

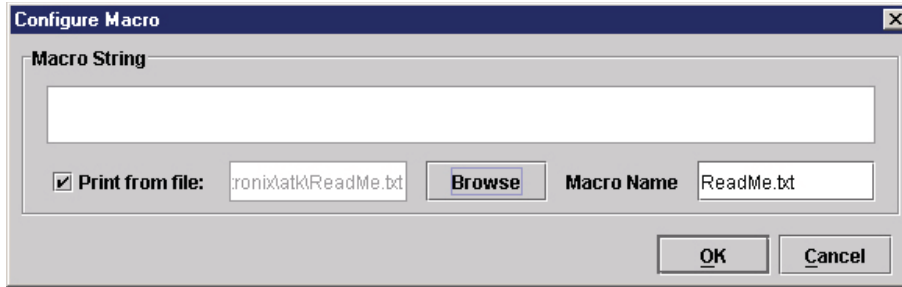

Figure 122 The Print from file Check Box

To use a file as a macro, check the **Print from file** check box. Then click **Browse** to locate your file (such as a **.txt** file). By default, the file name becomes the macro name. Rename it in the Macro Name field. See Figure 122.

Click **OK** to finish configuring the macro.

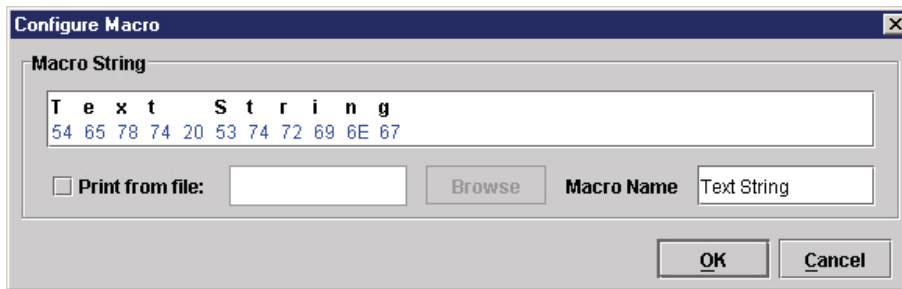

Figure 123 The Macro String Field

You can create a second kind of macro by typing in the Macro String field. The ASCII text appears above, and the hex code below. Use the up and down arrow keys to switch between ASCII text and hex code. Rename the macro in the Macro Name field. See Figure 123.

Click **OK** to finish configuring the macro.

The configured macros now appear in the list. See Figure 124.

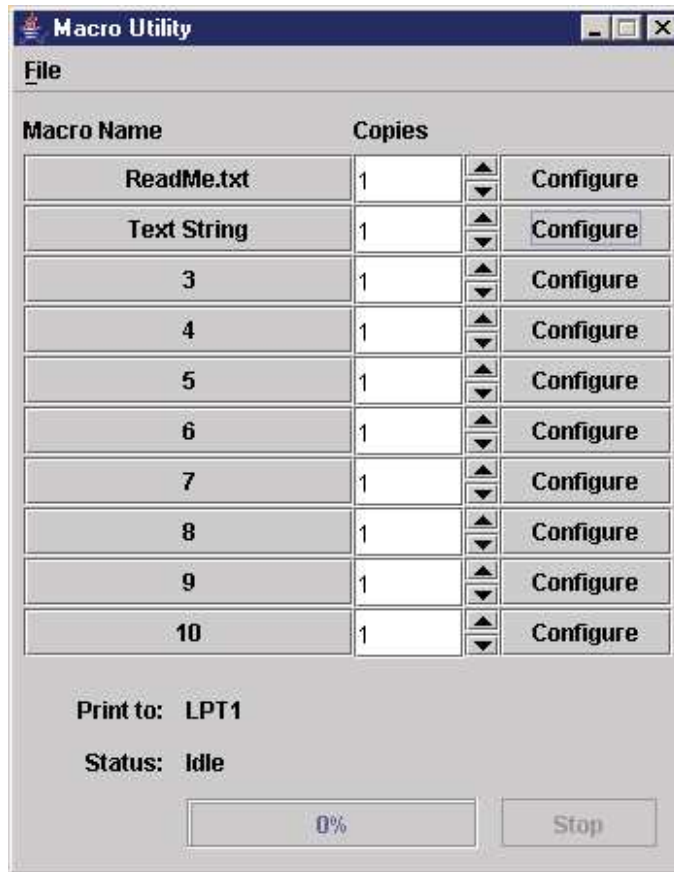

Figure 124 Configured Macros

Click the corresponding **Macro Name** button to send it to the printer. Adjust the number of copies in the **Copies** field.

SNMP Browser

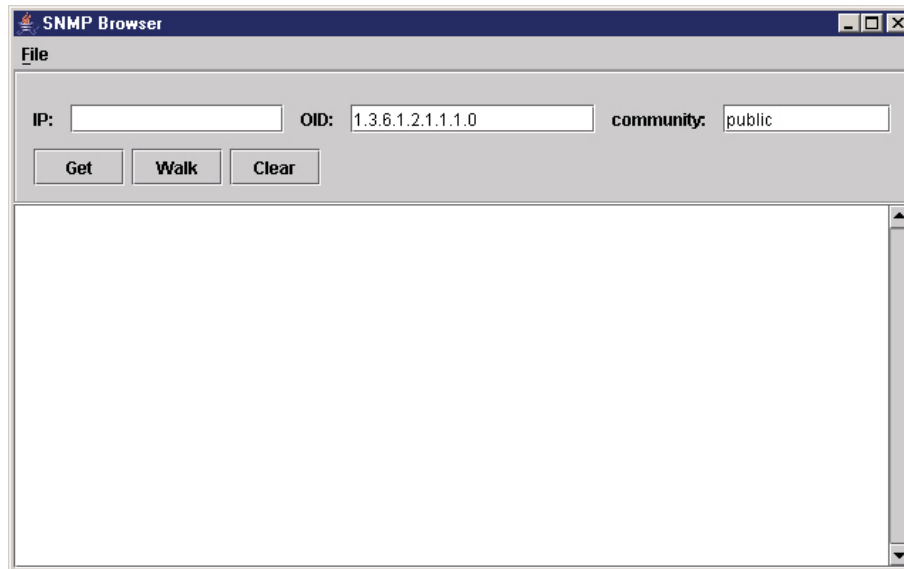

Figure 125 SNMP Browser

The SNMP Browser enables you to view attribute values in the Printer MIB managed by the NIC. You can retrieve an attribute value of a specific MIB Object ID (OID), or you can walk or traverse the MIB.

Three inputs are required before you can use the SNMP Browser:

1. **IP:** defines the IP address of the target printer.
2. **OID:** defines either the specific MIB object ID you want to view, or the starting location for the MIB walk.
3. **community:** defines the access community defined in the NIC. The default is public.

The **Get** button retrieves the attribute and attribute value for the specific OID entered. If the OID entered is invalid, you will receive the Error: SNMP error message.

The **Walk** button traverses the MIB starting with the OID entered. The display is in the format: OID=Attribute_Value.

The **Clear** button clears the current display.

The **File** menu allows you to open a previously saved SNMP Browser session, save the current session to file, or send the current session to a printer.

Assign IP Address

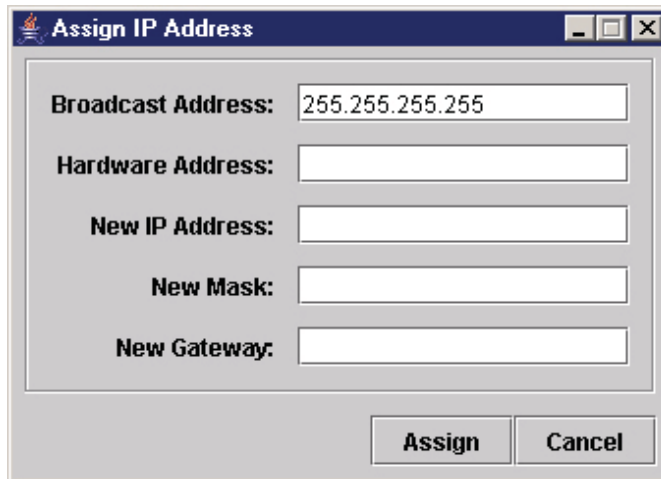

The screenshot shows a dialog box titled "Assign IP Address". It has a standard Windows-style title bar with a printer icon on the left and minimize, maximize, and close buttons on the right. The main area contains five labeled input fields: "Broadcast Address" (with the text "255.255.255.255" entered), "Hardware Address", "New IP Address", "New Mask", and "New Gateway". At the bottom right of the dialog are two buttons: "Assign" and "Cancel".

Figure 126 Assign IP Address

Allows you to assign IP addresses remotely to NICs that have not been previously configured, or to reconfigure the NIC settings. See Figure 126.

IMPORTANT This utility requires expert network knowledge. If you assign incorrect network parameters to the printer, then other devices on the network may operate improperly, possibly causing the whole network to be unusable.

The Assign IP Address utility has five fields:

- **Broadcast Address:** To enter a subnet broadcast number or a direct IP address to find the printer.
- **Hardware Address:** To enter the Machine Access Code (MAC) on the NIC.
- **New IP Address:** To assign the printer its new IP address. Make sure this address is correct and do not enter an already existing IP address.
- **New Mask:** To enter the new mask address, if necessary. If you need the same mask, type the mask number.
- **New Gateway:** To enter the gateway number the new printer uses. Once you click **Assign**, the NIC settings change immediately.

NOTE: To view the new settings on the operator panel, reset the NIC (refer to the *Network Interface Card User's Manual*) or reboot the printer: set the power switch to O (Off), wait 15 seconds, then set the power switch to I (On).

Enable Remote Printer Management

This sets the printer's diagnostic port to Ethernet, without having to navigate through the printer's operator panel.

It performs the following in the background:

1. Opens a command prompt session.
2. Executes a `telnet` command to the printer's IP address.
3. Logs in as `root`.
4. Executes the `enable printermgr` telnet command.
5. Closes the command prompt session.

NOTE: You must have Telnet root privileges to use this utility. See Telnet Root Password on page 58.

Select **Utilities ► Enable Remote Printer Management**, and the following dialog box opens:

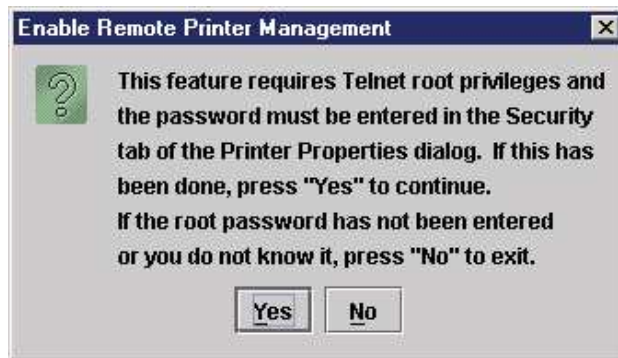

Figure 127 Enable Remote Printer Management Dialog Box

Click **Yes** to continue.

When remote printer management has been enabled, the following dialog box opens:

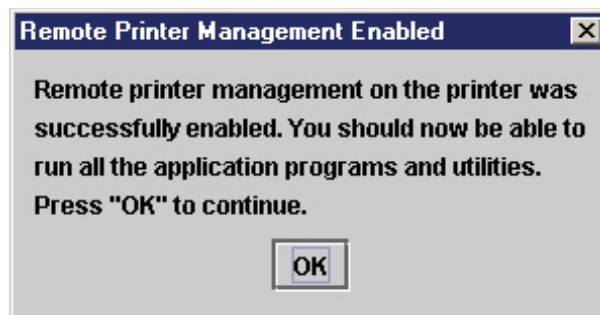

Figure 128 Remote Printer Management Enabled

If the following error message appears, then remote printer management has not been enabled.

IMPORTANT You may need to set the correct root password. See Security Tab on page 58.



Figure 129 Remote Printer Management Not Enabled

Lock/Unlock Menus



Figure 130 Lock/Unlock Menus Dialog Box

The Lock/Unlock Menus dialog box allows you to lock or unlock menus on a selected printer.

When you lock menus on a printer, the menu tree is disabled in the operator panel (physical and virtual). Any key that affects the menu tree such as +, -, ↑, ↓, ↵, UP, DOWN, NEXT, and PREV will not function. Also, any key that goes to a menu, e.g., the JOB SELECT or TEST PRINT key, will not function.

NOTE: When some of the above listed keys are used in combination with another to perform functions not related to the menu, they are not disabled.

Other keys not disabled are those that perform a function, e.g., PAUSE, FEED, ONLINE, PAPER ADVANCE, VIEW, SET TOF, PRT CONFIG, and PAGE EJECT.

Configure Print Servers

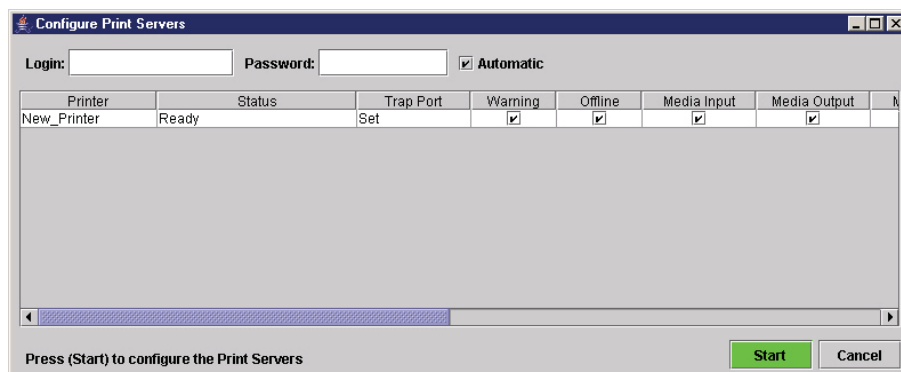



Figure 131 Configure Print Servers Window

To access the Configure Print Servers application, select one or several printers from the printer database then select **Utilities ► Configure Print Servers** or click the  **Configure Print Servers** button. The Configure Print Servers window appears (see Figure 131).

The Configure Print Servers application allows you to set the trap port according to the SNMP Trap Server setting (see page 27).

The Configure Print Servers application also allows you to select or deselect alert groups. To deselect an alert group, uncheck the check box(es) of the corresponding option(s). (By default all check boxes are checked.) The alert group options include:

- Warning
- Offline
- Media Input
- Media Output
- Media Path
- Marker
- Cutter
- Barcode
- RFID
- Scanner
- Intervention
- Consumable
- Label
- Power Cart

Click **Start** to configure the print servers.

NOTE: Check the **Automatic** check box to have PNE Auto ID connect directly with the printer.

Uncheck the check box to have PNE Auto ID make a Telnet connection with the printer. Enter **root** in the Login field and the password for the user **root** in the Password field.

When your printer encounters a problem that falls within the parameters of the selected alert options, the corresponding alert message appears. Refer to the Alert Groups Table in chapter three of the *Network Interface Card User's Manual* for descriptions of the alert message options.

NOTE: To check the print servers configuration, go to the NIC web page as discussed in chapter three of the *Network Interface Card User's Manual*.

5 *Datastream Adapter*

Overview

The datastream adapter is a software filter tool that allows you to take data from an incoming datastream and replace the data with different data, insert new data at any location in the datastream, or flush out portions of the datastream. This is accomplished through Character Substitution Tables (CSTs) created by the CST Manager (page 134). See Figure 132.

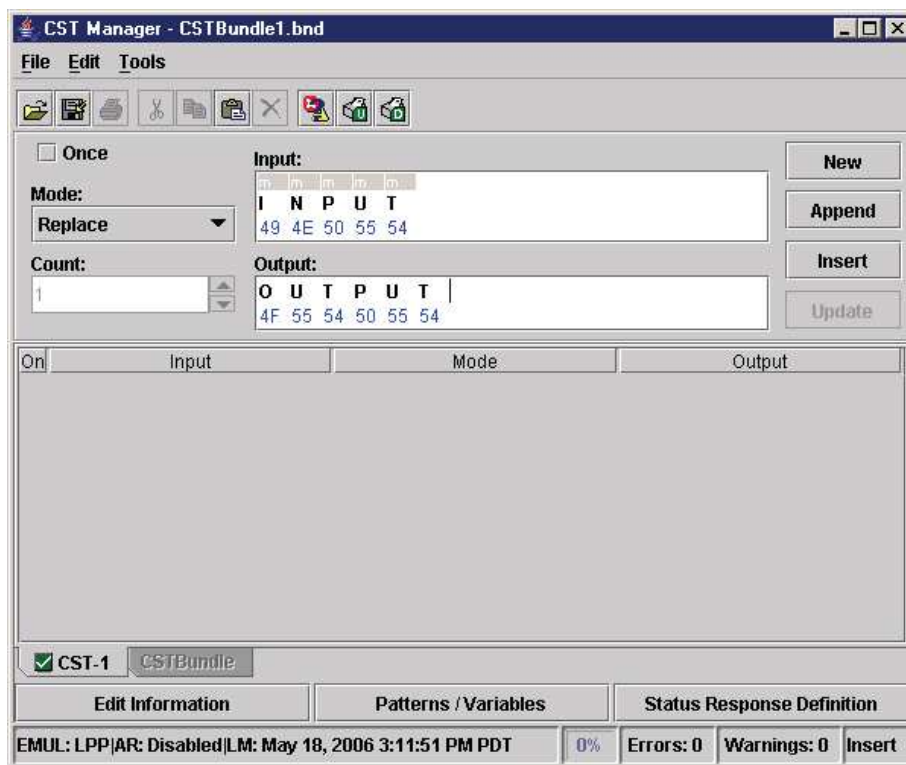



Figure 132 Creating a CST to Download Into a Printer

CST Manager

Using the CST Manager, you decide which data, as sent by the host, gets modified by the printer.

Open PNE Auto ID and select **Applications ► CST Manager** or click the  (CST Manager) button to open the CST Manager window. See Figure 133.

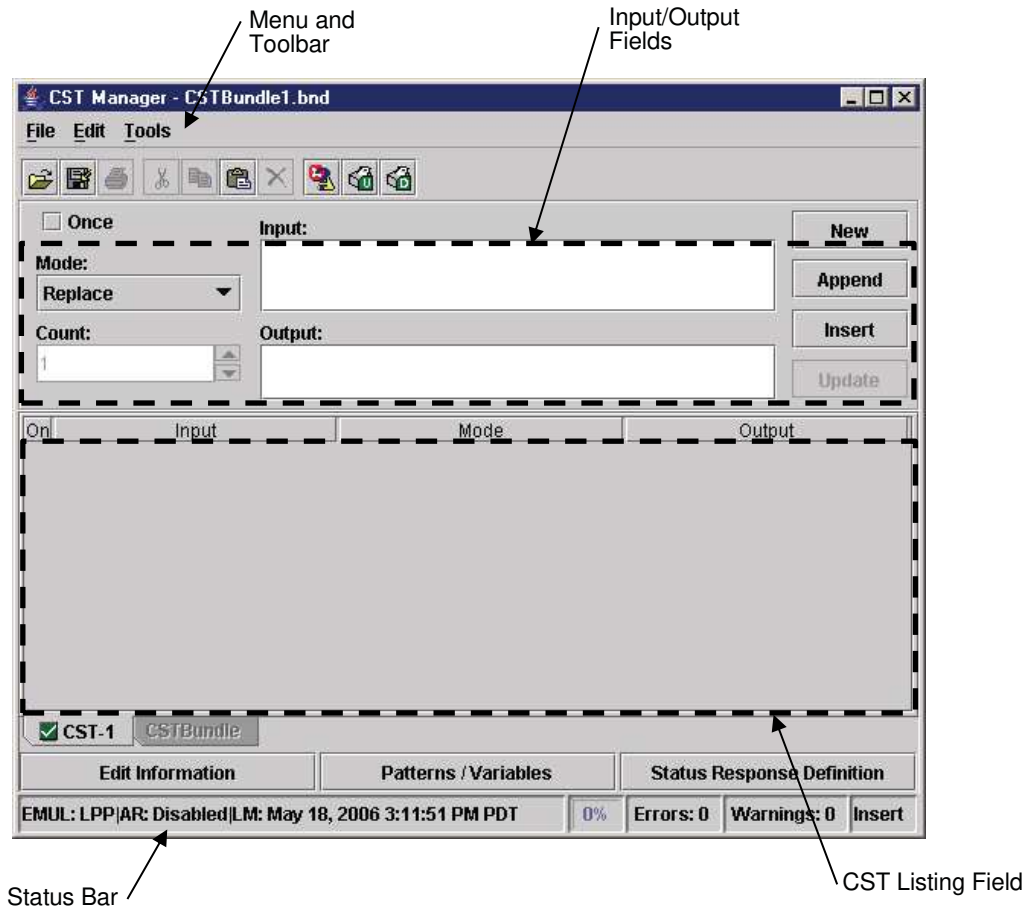
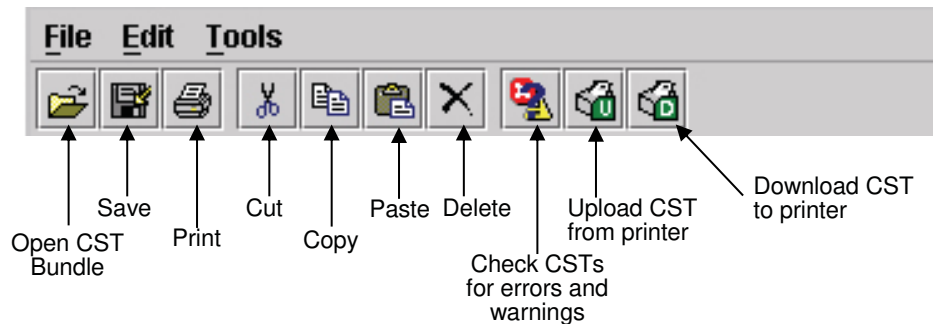

Figure 133 CST Manager Window

The CST Manager has a Toolbar, Input/Output fields, and a CST Listing Field.

The Menu And Toolbar



File

New: Closes the current bundle and creates a new one. See CSTs and CST Bundles on page 139.

Open: Opens a file dialog where you can select a CST bundle from a local disk. If the bundle has more than one CST, the first CST displays in the table.

Reopen: Displays the last eight opened CST bundles.

Save: Saves the current CST.

Save As: Similar to Save, except allows you to save the CST using a different location and name.

Backup History: Displays the backup history of a file. The system maintains the last 20 versions of a file.

Properties: Displays version information of a file.

Set Password: Sets the password for the current bundle.

Print: Prints selected CST entries.

Quit: Closes the CST.

Edit

Cut: Moves the selected item to the paste buffer. The paste buffer holds only one item at a time. When you cut another item, the paste buffer updates.

Ctrl + X is the shortcut.

Copy: Copies the selected item to the paste buffer. Ctrl + C is the shortcut.

Paste: Copies the contents of the paste buffer to the selected area. Ctrl + V is the shortcut.

Delete: Deletes the current selection.

Select All: Selects all entries in the active CST.

New CST: Adds a new CST to the bundle. CSTs have default names, but you can change them. Names can have only 8 characters.

Rename CST: Renames the CST.

Delete CST: Deletes the current CST from the bundle.

Import CST(s): Imports CST(s) from a bundle file.

Tools

Test

Tests the functionality of the active CST.

NOTE: The active CST is the CST currently selected/shown in the CST Manager window.

In the left (Input) pane of the Test dialog box, you can open and edit input files or create your own test files.

Click **Run**, and the active CST processes the input file and displays the results in the right (Output) pane.

Right-click in the Input or Output pane, and a View/Search pop-up menu appears. See Figure 134.

Available views are Normal (no control codes display), Dots (control codes display as dots), Mnemonics (control codes display as mnemonics, e.g., <LF>), and Hex (all characters display as a hex value).

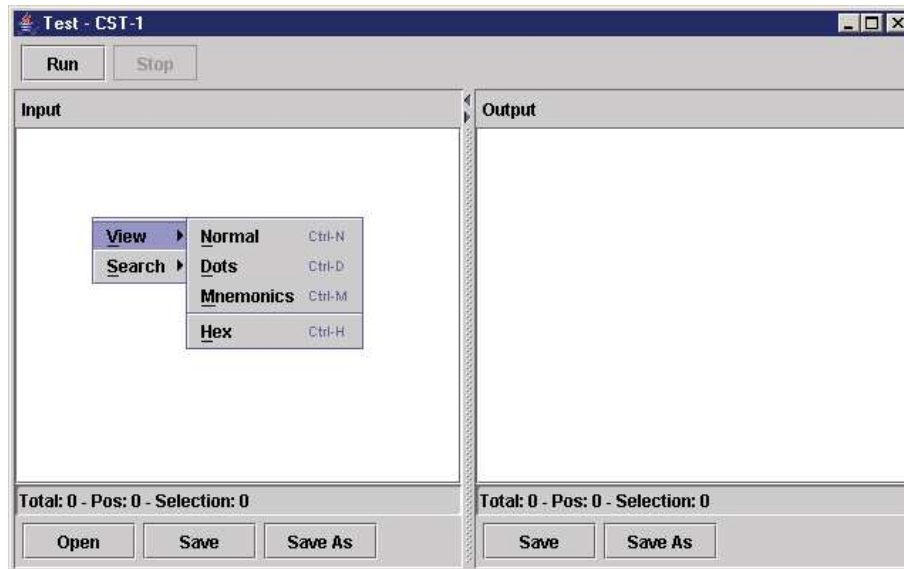

Figure 134 The View/Search Pop-up Menu

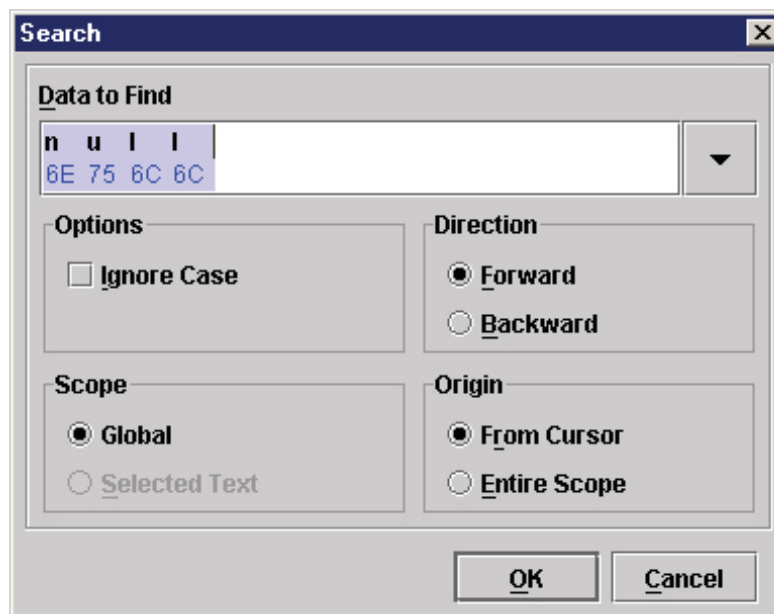

Figure 135 Search Dialog Box

Available searches are Find, Find Next, and Find Previous. If you select Find, a Search dialog box opens. See Figure 135.

Upload

Makes a connection to a printer from the printer database, then determines if the printer has a CST file. If so, it uploads the CST file into the CST manager. If the file is password protected, you will need to provide the password or the upload will cancel.

Download

Downloads the open CST file from the CST Manager to a printer. It makes a connection to a printer from the printer database, then determines if the printer has a CST file. If so, it warns you that the file will be overwritten if you proceed.

You must enable the CST option in the printer before you can use it. To enable the CST:

1. Open PNE Auto ID.
2. Select Applications ► CST Manager.
3. In the Input field, type **INPUT**.
4. In the Output field, type **OUTPUT**. See Figure 132.
5. Select File ► Save As.
6. Name the CST something simple such as **CST-1**, **CST-2**, etc.
7. In PNE Auto ID, select a printer.
8. In the CST Manager, select **Tools ► Download** to download your saved CST to the printer.
9. In PNE Auto ID, select Applications ► Operator Panel.
10. Take the printer offline.
11. Select **PRINTER CONTROL ► Applic. Adapter**
12. Change the setting from **Disable** to the name of the CST you downloaded (such as **CST-1**, **CST-2**, etc.). Your CST is now enabled.

NOTE: To maximize the performance of a CST, you need to save it in a Configuration file. See Configuration Editor on page 65.

Validate Bundle

Checks CSTs for syntax errors and missing information such as “Start Flush” commands that have no corresponding “End Flush” command. Errors display in red. Warnings display in yellow.

You cannot execute CSTs with errors, but you can execute CSTs with warnings.

Options

Specifies options that apply to the CST. Includes the following check boxes:

- Use Last Selected Upload Printer
- Use Last Selected Download Printer

Input/Output Fields

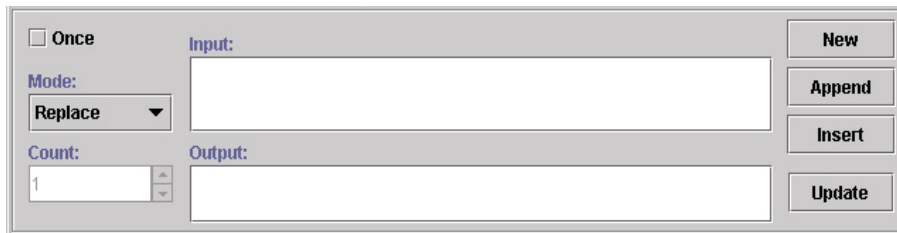

Figure 136 CST Input/Output Fields

These fields allow you to select the appropriate Input/Output sequence. Use Shift + Alt + i and Shift + Alt + o to switch between the Input and Output fields.

See Modes and Attributes on page 139 for the different Mode selections.

Use the four buttons on the right with the Input/Output fields.

New: Clears the Input and Output fields.

Append: Enters the Input and Output fields at the end of the current CST.

Insert: Enters the Input and Output fields before the selected entry in the CST.

Update: Re-enters the Input and Output fields into the current CST after editing.

Input Field

The Input Field displays the Input string the datastream adapter looks for. Enter Input strings in one of two ways: as an ASCII character or as a hex value. You can switch between the two entry modes by using the up and down arrow keys. To select attributes, place the mouse over a character and right-click. Available attributes display (see Modes and Attributes on page 139).

Output Field

Use the Output Field to specify what the datastream adapter does when the incoming data matches the data and conditions specified in the Input Field. Specify data if performing a Replace, or specify the name of a CST if performing a CST Select.

NOTE: Attributes are not available in the Output field.

The CST Listing Field

On	Input	Mode	Output

Figure 137 CST Listing Field

The field below the input and output fields shows the CST. To copy an entry, click it and press Ctrl + C or use the copy button on the toolbar. To move an entry up or down, click it and press Ctrl + up arrow or Ctrl + down arrow.

You can also click and drag an entry to a new position. Double-click an entry to place its data in the Input/Output fields. The area at the bottom of the dialog box lists statistical data about the use of CSTs, the available space, and the selected edit mode.

CSTs and CST Bundles

A CST contains all information necessary to perform an application adaptation. The CST size is limited to avoid complex adaptations that may affect printer performance, and to reduce printer memory usage. If a CST exceeds the size limit, an error message displays. The working space for a CST is approximately eight kilobytes.

CSTs are stored in a CST bundle. Each CST bundle can hold up to 64 CSTs. You can name and store as many CST bundles as the storage device allows.

You can define up to 8 different configurations, and each configuration can have a CST connected to it. Each configuration can have one CST, or one CST can apply to multiple or all configurations. When you download a CST bundle to the printer, the CSTs are available to the datastream adapter. You can then configure the printer to select the correct CST for your applications.

NOTE: Only one configuration and CST bundle can be active at a time.

Status Bar

The status bar, located at the bottom of the CST Manager window, displays the following items (in order):

- Status info:
 - EMUL: the emulation for which the CST is active.
 - AR: indicates if Enable Auto Reset is checked in the Edit Information dialog box. See Enable Auto Reset on page 145.
 - LM: date and time this CST was last modified.

A percentage bar which shows the total space used in the active CST.

Error count of the CST bundle.

Warning count of the CST bundle.

Edit mode: Insert over overwrite.

Modes and Attributes

Modes

Fourteen modes handle data: Replace, Remove, Insert, Flush, Transparent, Skip GFX Data, Select CST, CST ON, CST OFF, Reset, Response, PAA Event, Store, and Reset All Variables. Each mode allows certain attributes to apply to the characters of the datastream.

Common Attributes

All modes have four attributes in common: Match, Don't Care, Don't Care Except, and Ignore Case. Also, if at least one Pattern is defined, all modes have the Insert Pattern attribute. And, if at least one Variable is defined, all modes (except Store) have the Insert Variable attribute.

You can use these in combination (Or) with other attributes available in the selected mode. Some modes can use extra attributes. See page 142 for attribute information.

Replace Mode

The Replace mode replaces part of one datastream with another.

The extra attribute for Replace is Parameter.

Remove Mode

The Remove mode removes data from the datastream. For example, the CST can remove all occurrences of " (quotation mark) from the text that is sent to an Epson FX-1050 emulating printer.

No extra attributes exist for Remove.

NOTE: When using the Don't Care Except attribute, the Input string is removed from the datastream except when the Don't Care Except condition matches.

Insert Mode

The Insert mode inserts data in the datastream.

The extra attributes for Insert are Before and After (to specify the insertion point).

Flush Mode

The Flush mode is a combination of the Remove and Replace mode. It removes longer parts of datastreams without you needing to type in every character of that datastream, and replaces the removed data with new data.

The extra attributes for Flush are Start, End, and Count.

Transparent Mode

The Transparent mode allows you to control which data is removed, replaced, or modified. Sometimes the datastream of a graphics file contains a character sequence that is specified in the active CST for removal. If you mishandle this graphics file, important data could be removed.

The extra attributes for Transparent are Start, End, and Count.

Skip GFX Mode

The Skip GFX mode allows the Bit Image Graphics command to be recognized and the following data to become transparent which prevents the datastream adapter from removing selected strings from graphics. This allows graphic code to print properly.

The extra attributes for Skip GFX are 8-pin graphic data, 16-pin graphic data, 24-pin graphic data, and Graphic plot data.

Select CST Mode

The Select CST mode allows you to switch CSTs immediately. Use it if different conversions are required (one per job). You do not need to select the matching CST through the printer front panel.

This mode needs a unique header for each of the jobs requiring a CST to activate. Once a switch occurs, the datastream adapter resets, selects the indicated CST, and restarts.

NOTE: Buffered data (the portion of the incoming datastream that invokes the Select CST mode) is not deleted; it is rescanned using the new CST.

No extra attributes exist for Select CST.

CST On, CST Off Mode

These modes prevent data handling by CSTs until enabled by part of the incoming datastream.

No extra attributes exist for CST On and CST Off.

Reset Mode

The Reset mode is used to reset the CST such that, if the Use Once flag has been set for one or more entries in the table, these entries become available again for the next datastream. See The Use Once Flag on page 144.

No extra attributes exist for Reset.

Response Mode

This feature was added to the datastream adapter to allow the definition of a protocol: an interaction between the host computer and the printer that allows the host computer to determine status details of

the printer. This allows you to be certain that a job (or label, or form) is completely printed before the next job is sent.

The Status Response definition feature allows the user to specify what input string will be used by the host computer to request a status report from the printer. It also allows the actual response to be defined, and the connection of a certain printer status as a condition to this response.

The extra attribute for Response is Flush.

PAA Event Mode

In the PAA Event mode, when the defined character sequence in the Input field is found, an event is generated that can be handled by the GPIO. The event generated is determined by the Event ID value. Up to 65,535 different events can be identified using the Event ID parameter.

The extra attribute for PAA Event is Flush.

Store Mode

The Store mode is used to store information from the host data so it can be used by other modes that allow variables in the Output field. It requires exactly one variable to be set in the OCS field. As a result this mode can only be selected if one or more variables are defined.

Right-click the Output field and a pop-up menu appears with the available variables. See Figure 138. All characters in the Input field that have the Include attribute selected (see Attributes on page 142) are copied into the selected variable. By default, all characters typed or copied into the Input field have the Include attribute selected. The entry can only be added to the active table if a variable has been set. If you select the wrong variable, the variable in the Output field needs to be removed first before another variable can be selected.

The extra attributes for Store are Flush and Include.

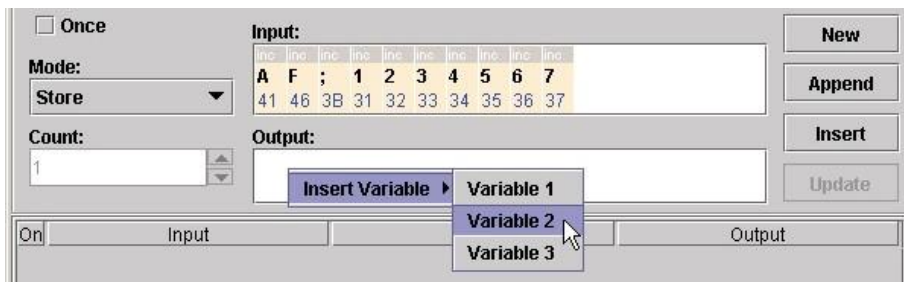

Figure 138 Available Output Variables for Store Mode

Reset All Variables Mode

The Reset All Variables mode resets and clears all defined variables.

No extra attributes exist for Reset All Variables.

Attributes

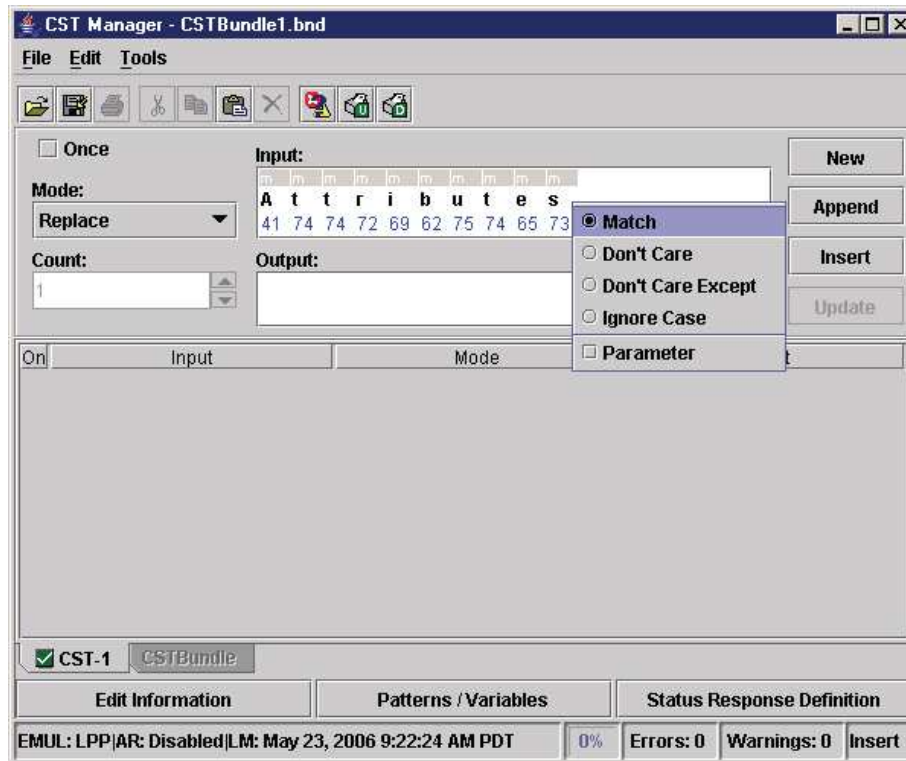

Figure 139 CST: Accessing Attributes

To access attributes, right-click any item in the Input field (or select multiple items and right-click). Different attributes are available depending on what mode is selected (see Modes on page 139). In the above example, the “s” in “Attributes” was right-clicked while in Replace mode. See Figure 139.

These are the different attributes used by the various modes and their descriptions:

Match

The most common and simplest Attribute. If the specified character(s) match the datastream, then a replacement occurs if in Replace mode. It is the default setting.

Don't Care

Allows certain characters in the datastream to be wild cards; that is, it does not matter what character it is. If the others match, then the replacement occurs if in Replace mode.

Don't Care Except

Allows characters in the datastream to be wild cards, but only if they do not match the character specified.

Ignore Case

Allows the matching of characters to be case independent. Whether the character is “X” or “x” a match occurs.

Parameter

Allows characters in the incoming datastream to have a “label.” You can use this label in the outgoing datastream to move characters to other locations without changing them. If the outgoing datastream has no label specified, then the character is removed from the incoming datastream.

Before/After

Specifies where the data is inserted.

Start/End

Starts and stops data flushing (activates and deactivates the datastream adapter). Any data in the Output field passes to the printer instead of being flushed.

Count

Specifies a fixed number of characters that are flushed following the Count attribute (deactivates the datastream adapter). The fixed number is specified in the Count field.

Flush

Removes the input string from the datastream, preventing it from being printed.

Include

Specifies that the character that has the attribute will be included in the Store mode operation.

Insert Pattern

Allows a defined pattern to be inserted in the CST. See Patterns / Variables on page 146.

Insert Variable

Allows a defined variable to be inserted in the CST. See Patterns / Variables on page 146.

Additional Features

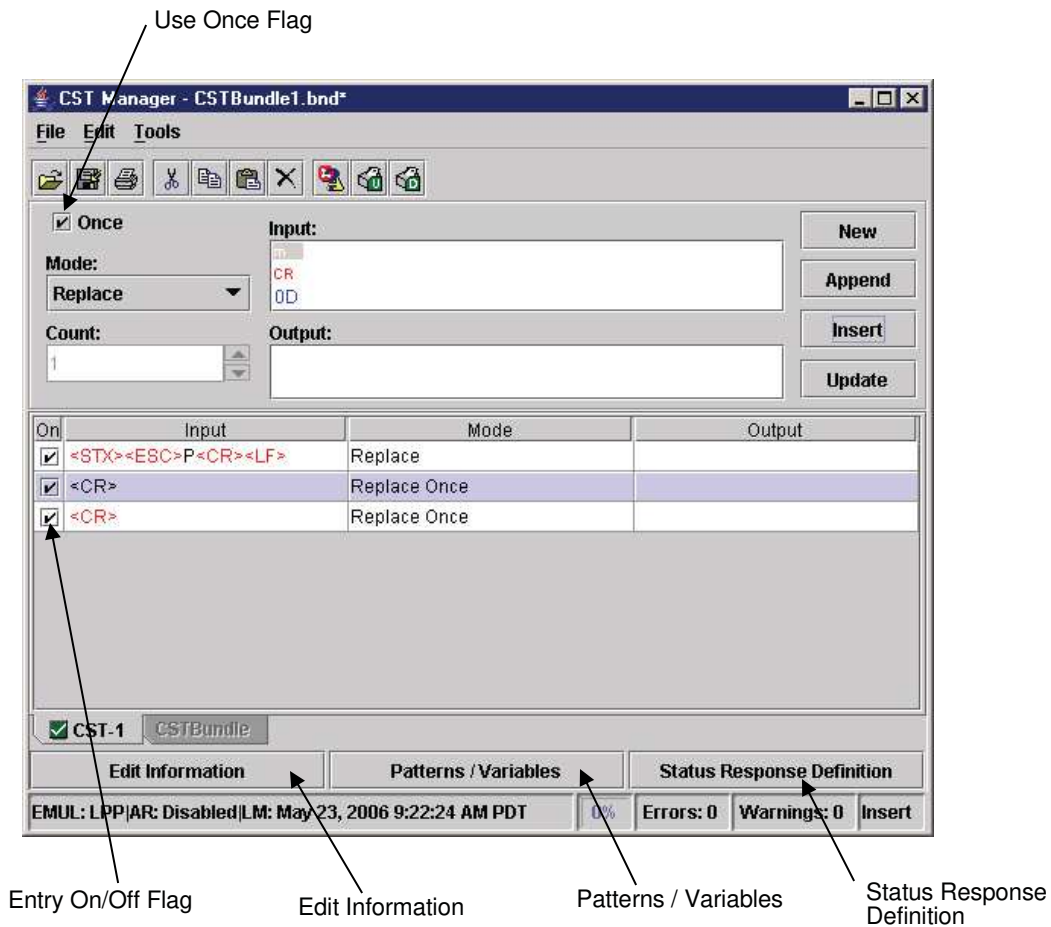

Figure 140 Additional Features

The Use Once Flag

This flag, which is set during the entry of a CST, is used when it is impossible to create entries in the table that are unique enough to allow for different outputs according to each of the entries. This might be the case when data extraction is done and the printable data is always preceded or followed by the same character (or sequences).

NOTE: A positive note in using this flag is that as more CST entries get marked as “used,” the less entries need to be checked by the datastream adapter and the faster the conversion takes place. Even if you do not need the flag to compensate for a lack of uniqueness in the incoming data, setting the flag for entries that will occur only once improves the throughput of the datastream adapter.

When the end of the CST has been reached, the used flags will need to be reset so that this CST can be applied to the next datastream.

To reset the used flags:

- Append the Reset mode to the CST.
- Check the Enable Auto Reset check box in the Edit Information dialog box. See Edit Information on page 145.

NOTE: The only difference between the two methods is that the Reset mode can be placed anywhere in the CST. The Enable Auto Reset flag takes effect only when the end of the CST has been reached.

The Entry On/Off Flag

This flag is used to temporarily enable/disable entries in the CST. It can be used for testing purposes and for diagnosing large CSTs. The default for this flag is On.

Edit Information

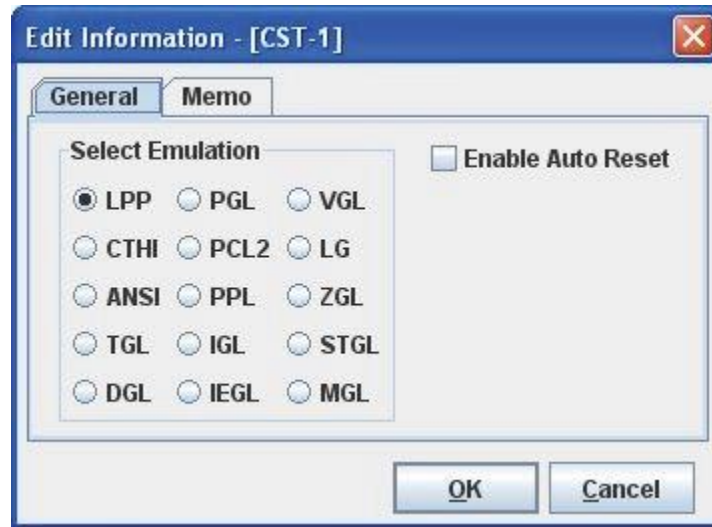

Figure 141 Edit Information Dialog Box

Click **Edit Information**, and the Edit Information dialog box opens.

General Tab

Select Emulation: Allows you to select the emulation that is active for the CST. Even though the printer can store many emulations, only one can be active for the CST. LPP is the default emulation.

Enable Auto Reset: When checked, all entries that have the Once option checked are automatically reset in the CST so that this CST can be applied to the next datastream. The entries are reset only when the end of the CST has been reached.

Memo Tab

Use the Memo tab to save comments with the CST (e.g., comments that describe the CST function and purpose).

Patterns / Variables

Click **Patterns / Variables**, and the Object Definition dialog box opens.

This dialog box is divided into the following tabs: Pattern Character, Pattern, Formatted Pattern, and Variable. When you click OK, the defined set of patterns, pattern characters, formatted patterns, and variables will be available for use by the current bundle.

IMPORTANT You must add defined objects to their associated lists, or they will be lost when you close the Object Definition dialog box.

Pattern Character Tab

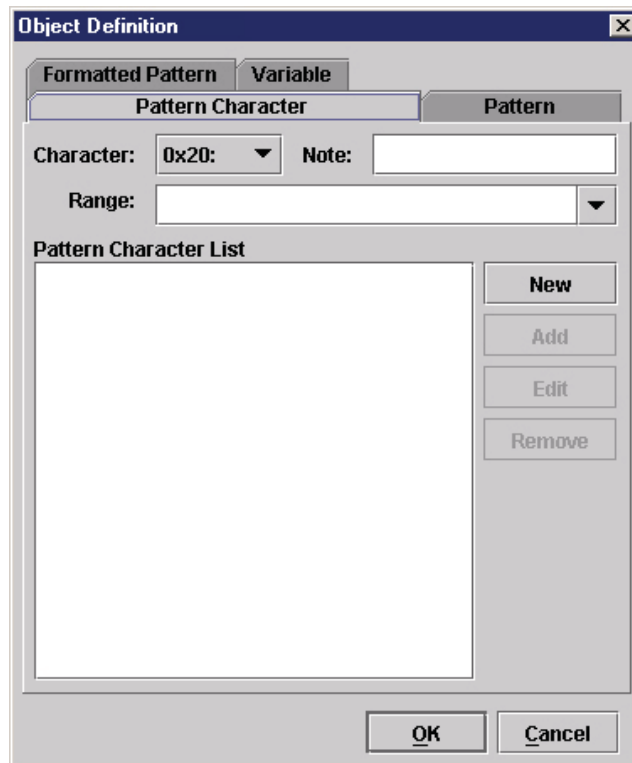

Figure 142 Patterns Character Tab

Use the Pattern Character tab to add, remove, and edit new and existing pattern characters. A pattern character can be used by the datastream adapter to check host data against a range of values.

Character: Selects the character that identifies the pattern character. The available values range from 0x20 to 0xFF. The values 0x00 to 0x1F are reserved. The values are listed with their hex value and printable character. If you select a character already defined in the drop-down list, the properties for the character will display in the Note and Range fields. You can change the data and click **Update** to update the definition in the Pattern Character List.

NOTE: A short note, description, or name of the pattern character. This will appear in pop-up menus where you insert and use pattern characters.

Range: The range of values datastream adapter checks against.

NOTE: A continuous interval is separated by two dots, e.g., **a..z**.

Enter hex values with the prefix **0x**. To define a continues hex interval, enter **0xNN..0xNN** (where NN is a value ranging from 00 to FF).

You can define multiple intervals per pattern character by separating the intervals with a , (comma) or a space character.

NOTE: To include an interval separator, enter them either as hex, e.g., **0x20** and **0x2C**, or make it part of a continues interval, e.g., **0x10..0x30**.

Default Pattern Characters

You can select a set of default pattern characters by using the Range drop- down list. The Character and Note fields of the default pattern characters are set to the values listed in Table 8. If you choose a default pattern and the identifier (character) is already in use, the first unused identifier from the Character drop-down list is used.

Table 8 Default Pattern Characters

Range	Identifier (Character)	Note
0..9	#	Numerals
A..Z	U	Uppercase
a..z	L	Lowercase
A..Z, a..z	A	Alpha
0..9, A..Z, a..z	@	Alpha Numeric
0..9, A..F, a..f	H	Hex Values
0x00..0x1F	C	Ctrl-Codes
0x20..0x7F	P	Printables
0x80..0xFF	S	Upper Set

Pattern Character List

Lists all the patterns characters that you have defined and added to the list.

New: Click **New** to reset the Range and Note fields. The first unused identifier from the Character drop-down list is chosen.

Add: If the displayed text on the second button is Add, the pattern character (with chosen identifier) has not been added to the Pattern Character List. Click **Add** to add the defined pattern character to the end of the Pattern Character List.

Update: If the displayed text on the second button is Update, the pattern character (with chosen identifier) is already in the Pattern Character List. Click **Update** to update the pattern character properties with the new properties.

Edit: Select an item in the Pattern Character List, and click **Edit** to edit it.

NOTE: If you select more than one item, you can only to edit the first item.

Remove: Select one or more items in the Pattern Character List, and click **Remove** to remove them from the list.

IMPORTANT Removing pattern characters invalidates entries that use the pattern characters.

Pattern Tab



Figure 143 Pattern Tab

Use the Pattern tab to add, remove, and edit new and existing patterns.

Name: The name of the pattern. The name must be unique for this type of datastream adapter object. This name appears in pop-up menus when you insert and use patterns.

Pattern: To enter the pattern in a way similar to defining the input of a CST entry (see Input Field on page 138). If you type a character that is defined as a pattern character (see Pattern Character Tab on page 146), the default attribute will be Pattern Character: it will display over a light green background with the mnemonic **pch**. To use the character as a literal, right-click the character and select the **Match** attribute.

Pattern List

Lists all the patterns you have defined and added to the list.

New: Click **New** to clear the Name and Pattern fields and create a new pattern. Use a unique and descriptive name. This name appears in pop-up menus when you insert a pattern.

Add: If the displayed text on the second button is Add, the defined pattern has not been added to the Pattern List. Click **Add** to add the pattern definition to the end of the Pattern List. The pattern appears in the list with its name followed by a separator and the pattern.

NOTE: If the pattern contains control codes, they will display in red. Other non-printable characters will display as red dots.

Update: If the displayed text on the second button is Update, the defined pattern is already in the Pattern List. Click **Update** to update the pattern properties with the new properties.

Edit: Select an item in the Pattern List, and click **Edit** to edit it.

NOTE: If you select more than one item, you can only to edit the first item.

Remove: Select one or more items in the Pattern List, and click **Remove** to remove them from the list.

IMPORTANT Removing patterns invalidates entries that use the patterns.

Move Up/Move Down: Patterns appear in pop-up menus in the order that they appear in the Pattern List. Select an item in the Pattern List, and click **Move Up** or **Move Down** to move the pattern up or down on the list.

Formatted Pattern Tab

Use the Formatted Pattern tab to add, remove, and edit new and existing formatted patterns. You can use a formatted pattern to identify host data patterns that do not have a fixed length.

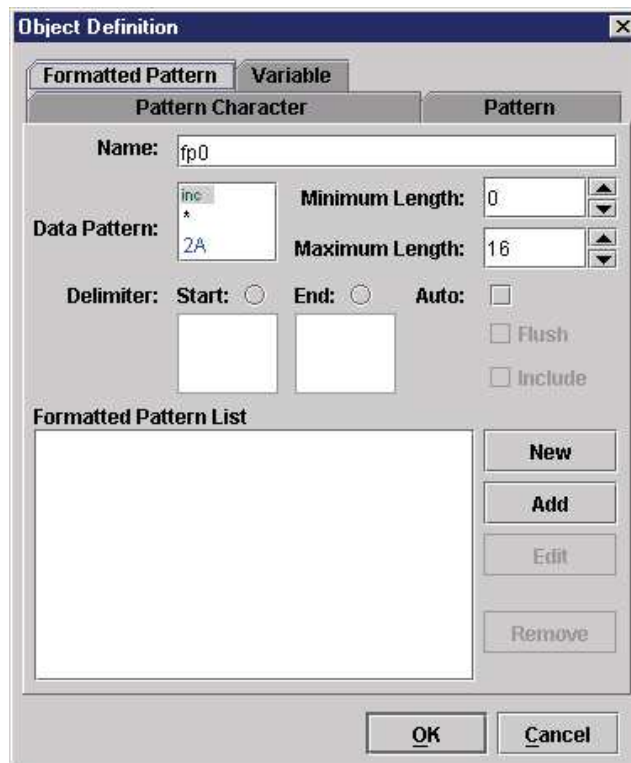

Figure 144 Formatted Pattern Tab

Name: The name of the formatted pattern. The name must be unique for this type of datastream adapter object. This name appears in pop-up menus when you insert and use formatted patterns.

Data Pattern: To insert a single character that is used as the data pattern. This may either be a pattern character or any other character with the default Don't Care attribute. The default for this field is * (asterisk) with the Don't Care and Include attributes.

Right-click the character and the following pop-up menu appears:

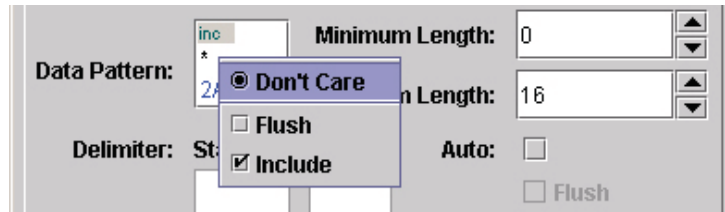

Figure 145 Data Pattern Pop-up Menu

If you use a data pattern character that is not defined as a pattern character, the Don't Care attribute is always selected. Use the Flush attribute to flush the found data from the host data. Use the Include attribute include the found data in Store operations. The Include attribute is selected by default.

If you use a data pattern character that is defined as a pattern character, the Pattern Character attribute will be selected by default, and the background of the **inc** mnemonic will be light green. To change it to a wild card character, right-click the character. The attribute pop-up menu appears. See Figure 146.

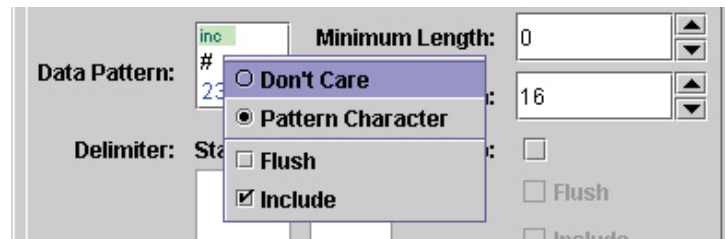

Figure 146 Pattern Character Pop-up

The Pattern Character attribute is selected by default. To use the data pattern character as a wildcard, select the **Don't Care** attribute.

Minimum Length: Defines the minimum length the pattern must have. If the data pattern is set to scan for numerals using a pattern character, it must find at least *n* numerals (the value set by this property) before a match is considered.

Maximum Length: Defines the maximum length the pattern may have. If the data pattern is set to scan for numerals using a pattern character, it only scans for a maximum of *n* numerals (the value set by this property) before a match is made.

Delimiter

Use delimiters to find data easier. You can look only for a start delimiter, end delimiter, start and end delimiters, or auto delimiter.

Start: When you enable Start, a pattern match occurs only when the Start character is found. The Start character may be a single character or a pattern character, and it has the Flush and Include attributes.

End: When you enable End, a pattern match occurs only if the End character is found at the end of the data pattern and the maximum length is not exceeded. The End character may either be a single character or a pattern character, and it has the Flush and Include attributes.

Auto: When you check the Auto check box, the pattern considers the first character found to be the start and end delimiter. See the following example.

NOTE: In the following example, items enclosed in <> indicate datastream adapter objects like Pattern, Pattern Character, etc. Random host data is indicated by “...” preceding and/or following the sample data.

Auto Example:

Pattern Character

Identifier: #
Range: 0..9
Note: Numerals

Formatted Pattern

Name: fpFieldData
Data Pattern: <#>
Min: 0
Max: 5
Delimiter: Auto

Entry 1

Input: AF;< fpFieldData >
Mode: Remove
Output: N/A

Test Case 1

Host data:AF;"12345"....
Result: Match for Entry 1
Reason: As delimiter is set to auto the first quote is seen as the start and end delimiter.

Test Case 2

Host data:AF;"123456"....
Result: No Match
Reason: Max length exceeded.

Test Case 3

Host data:AF;"01234"....
Result: No Match
Reason: No Matching end delimiter.

Formatted Pattern List

Lists all the formatted patterns that you have defined and added to the list.

New: Click **New** to reset all data fields.

Add: If the displayed text on the second button is Add, the formatted pattern has not been added to the Formatted Pattern List. Click **Add** to add the defined formatted pattern to the end of the Formatted Pattern List.

Update: If the displayed text on the second button is Update, the formatted pattern is already in the Formatted Pattern List. Click **Update** to update the formatted pattern properties with the new properties.

Edit: Select an item in the Formatted Pattern List, and click **Edit** to edit it.

NOTE: If you select more than one item, you can only to edit the first item.

Remove: Select one or more items in the Formatted Pattern List, and click **Remove** to remove them from the list.

IMPORTANT Removing formatted patterns invalidates entries that use the formatted patterns.

How to Use Patterns

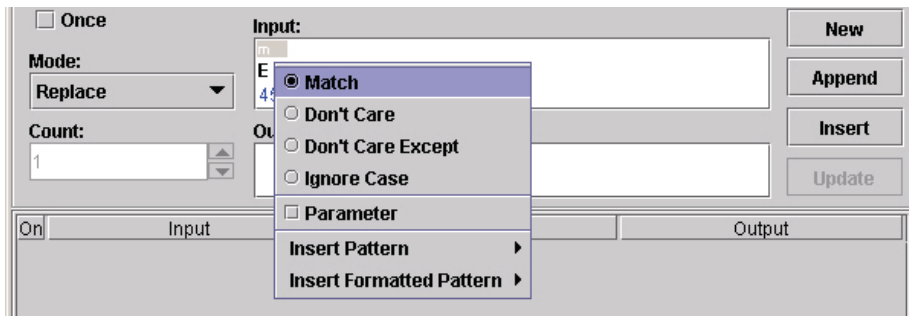

Figure 147 Inserting Patterns in the Input Field

Once you define the patterns you can use them in CST entries. To insert a pattern, right-click a character from the input string. Insert Pattern and/or Insert Formatted Pattern displays at the bottom of the pop-up menu. See Figure 147.

Use these menus to insert your pattern or formatted pattern. The pattern will be inserted before the character. To append a pattern, right-click past the end of the Input string.

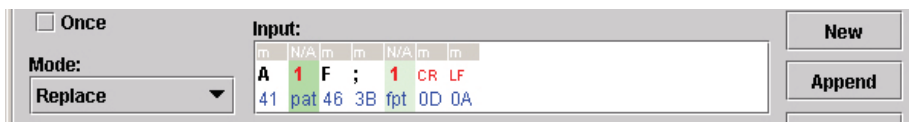

Figure 148 Inserted Patterns

A pattern has an index number in red on a light green background with the mnemonic **pat** below the index number. A formatted pattern uses the mnemonic **fpt**. See Figure 148.

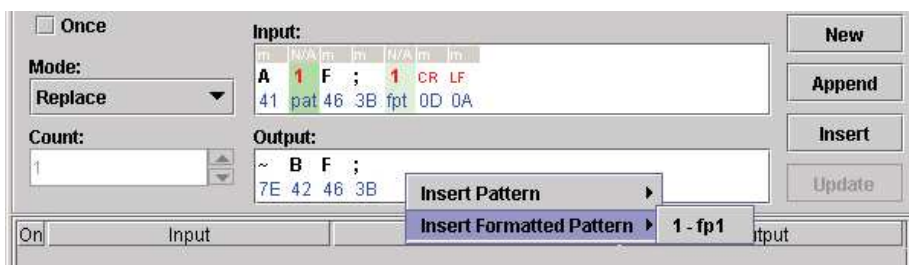

Figure 149 Inserting Patterns in the Output Field

The same formatted pattern may be used more than once in the Input field. When you want data found by the pattern to be copied to the Output field, use the index number (in red) to identify the data. To add a pattern to the Output field, use the same procedure as for the Input field. The Insert Pattern and Insert Formatted Pattern menus list all patterns used in the Input field with the index number in front of the pattern name. See Figure 149.

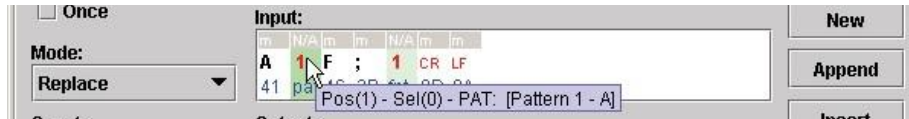

Figure 150 Pattern Screen Tip

To see pattern details, i.e., name and definition, hover the pointer over the character in the Input field to display a screen tip. See Figure 150.

NOTE: For some Modes, you cannot insert patterns into the Output field.

Pattern Recognition Example

Normally, the CST only allows you to do an absolute match on a character. It has not been possible to check if a character is within a given range of characters (unless you write a very complicated CST).

Pattern recognition allows the user to specify either a range of characters or a specific pattern with a unique name that can be used to test the input data against.

Example

The following command sets the label size for thermal printer 1:

```
<ESC>Daaaa,bbbb,cccc<LF><NULL>
```

where *aaaa* is the length of the label, *bbbb* is the effective print width and *cccc* is the effective print length.

NOTE: *aaaa*, *bbbb*, and *cccc* are always fixed at 4 digits with a value range of 0000 to 9999.

Convert this command (assuming the units are the same) into the PGL PAPER command for thermal printer 2.

Start with a CST that will translate the <ESC>D into PAPER. Skip the value of *aaaa* since thermal printer 2 can detect the forms length using the CALIBRATE function. The value of *bbbb* will be used in combination with the WIDTH function, and the value of *cccc* in combination with the LENGTH function. This results in the following translation:

```
Thermal printer 1: <ESC>Daaaa,bbbb,cccc<LF><NULL>
```

```
Thermal printer 2: PAPER;CALIBRATE;LENGTH cccc;WIDTH bbbb<CR><LF>
```

To be able to copy the value of *bbbb* into the WIDTH function and the value of *cccc* into the LENGTH function, label these values and specify their ranges to be from 0000 to 9999.

To do this, use the Object Definition capability of the datastream adapter.

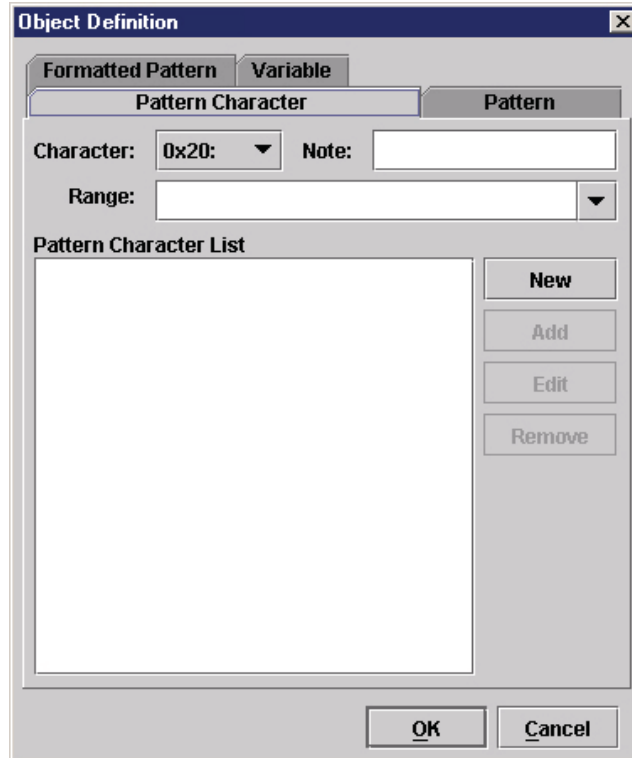

Figure 151 Object Definition: Pattern Character

1. In the CST Manager, click **Patterns / Variables**. See Figure 151.

Next, define the required pattern character by selecting it from the list of available characters.

2. Click the **Character** down arrow and select **0x23: #**. The # character will be used as a label.

NOTE: The total number of different pattern characters that can be selected is 224.

3. If necessary, enter a note to go with this label in the Note field. For example, use Length if the Pattern Character is going to be used for the Length value of the command to translate.

4. Type **0 . . 9** in the **Range** field. This is the range of values this label can have.

NOTE: A range is specified using two periods in sequence, i.e., 0..9 or A..Z. A comma should be used as a delimiter if more than a single range or value is specified for a pattern character, i.e., A..Z,0..9 if the range should cover both uppercase alpha and numeric values.

Use the Range down arrow to select pre-defined ranges.

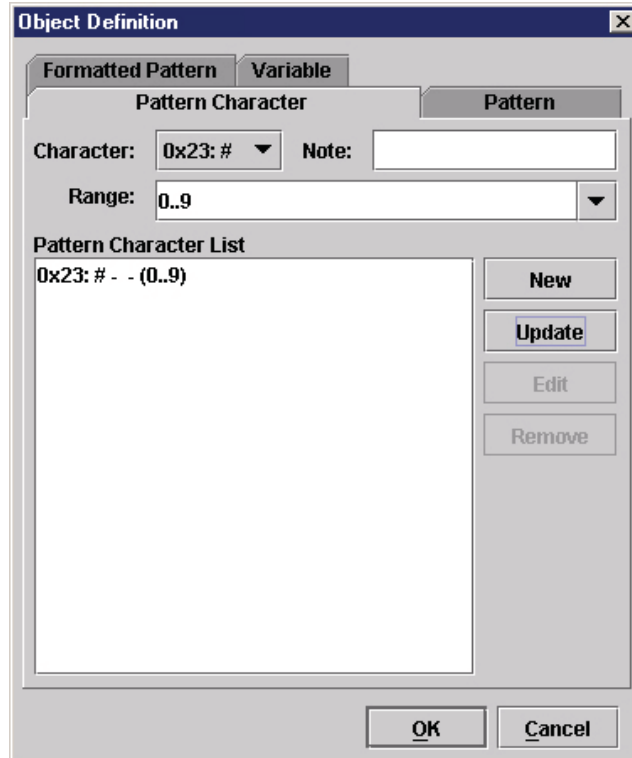

Figure 152 Defining a Pattern Character

5. Click **Add** to add the pattern character to the list. See Figure 152.

Next, set up a full pattern using the pattern character just defined.

6. Click the **Pattern** tab.

7. Type **Length** in the Name field. This is the name of the first pattern.

8. In the Pattern field, type **####** for the pattern character to be used.

NOTE: The number of pattern characters that can be entered to form a pattern is unlimited.

9. Click **Add** to add the pattern to the list.

10. Click **New** to clear the Name and Pattern fields.

11. Type **width** in the Name field. This is the name of the second pattern.

12. In the Pattern field, type **####** for the pattern character to be used.

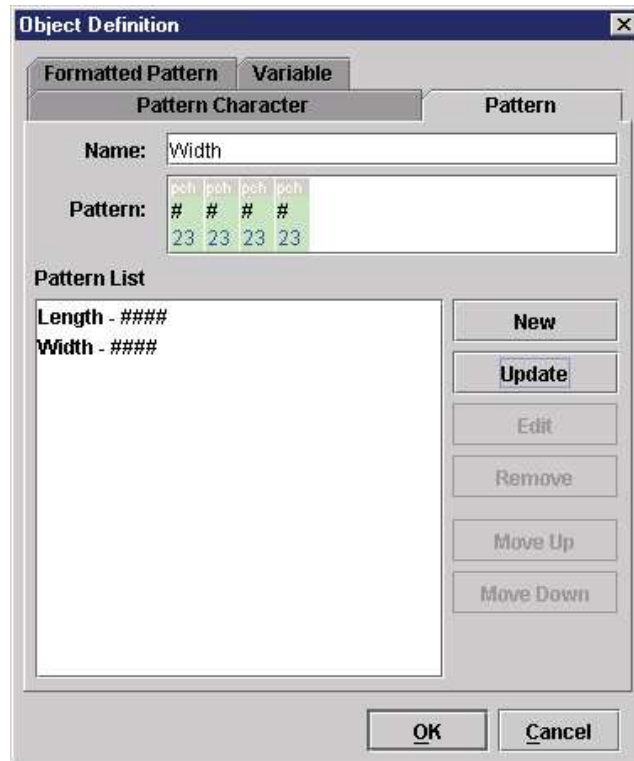

Figure 153 Defining Patterns

13. Click **Add** to add the pattern to the list. See Figure 153.
14. Click **OK** to return to the CST Manager.

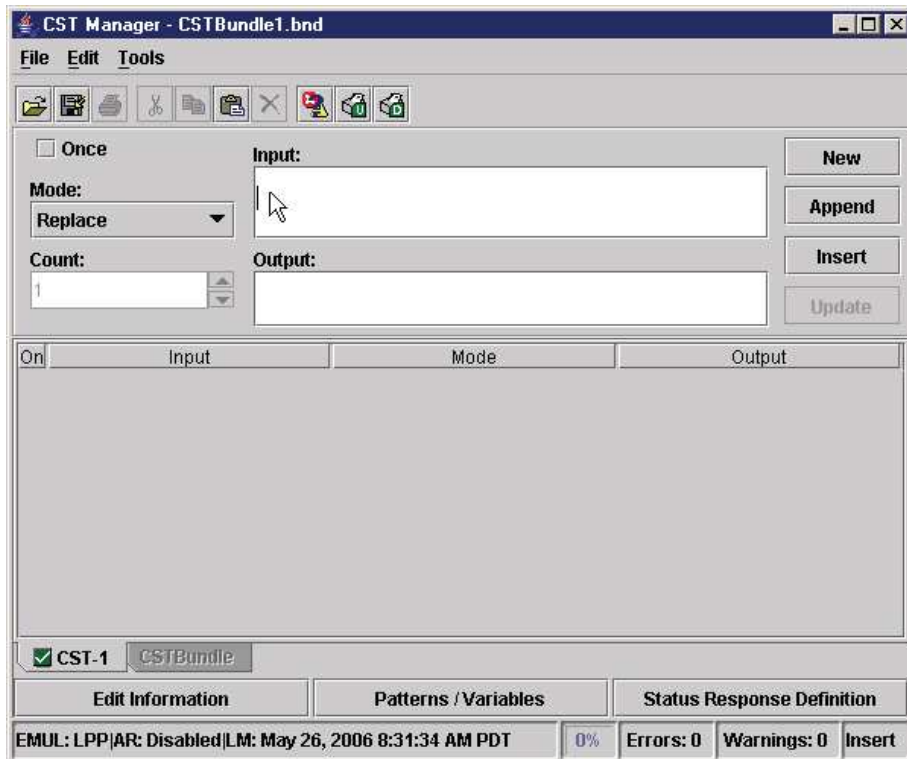

Figure 154 Selecting the Input Field

Now you can use the just defined pattern in the CST. Create an entry in the CST where the input field specifies the thermal printer 1 command sequence *bbbb* be replaced by the Width pattern and *cccc* be replaced by the Length pattern.

15. Click the **Input** field to place the cursor. See Figure 154.
16. Press the down arrow key to enter Hex entry mode.
17. Type **1B** (for ESC).
18. Press the up arrow key to enter ASCII entry mode.
19. Type **Daaaa ,**
20. Right-click to the right of the last character position.
21. Hover the pointer over **Insert Pattern**. A list of available patterns displays.
22. Select **Width**.
23. Press the right arrow key to reposition the cursor and type **,** (comma).
24. Right-click to the right of the comma and select **Insert Pattern ► Length**.

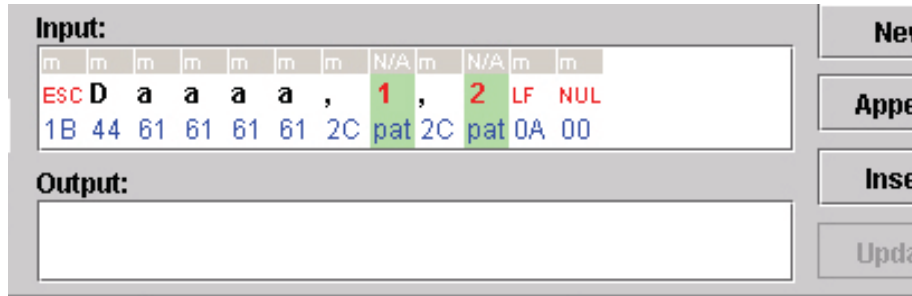

Figure 155 Entering the Input String

25. Press the right arrow key, then the down arrow key and type `0A00` (for LF and NUL). See Figure 155.

NOTE: The entry in the CST will show “pat” (Pattern) in the attribute field and a pattern number in the character field. The hex value shown below the pattern number has no specific meaning.

Since the `aaaa` value is not going to be used, we need to give these characters the Don't Care attribute.

26. Select `aaaa`.

27. Right-click the selected `aaaa` and select **Don't Care**. The attribute field changes from “m” (Match) to “dc” (Don't Care).

28. In the Output field, type `~PAPER;CALIBRATE`. This PGL command replaces the “<ESC>Daaaa” part of the thermal printer 1 command.

29. Continue by typing `;LENGTH[space]`.

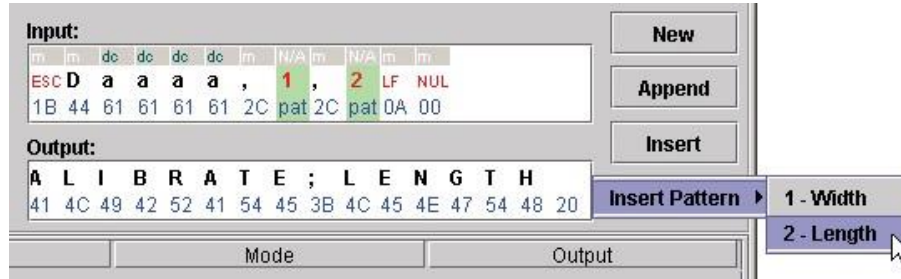

Figure 156 Entering the Output String

30. Right-click at the insertion point and select **Insert Pattern ► 2 - Length**. See Figure 156.

NOTE: Make sure you right-click to the right of the space.

31. Press the right arrow key and type `;WIDTH[space]`.

32. Right-click at the insertion point and select **Insert Pattern ► 1 - Width**.

33. Press the right arrow key, then the down arrow key and type `0D0A` (for CR and LF).

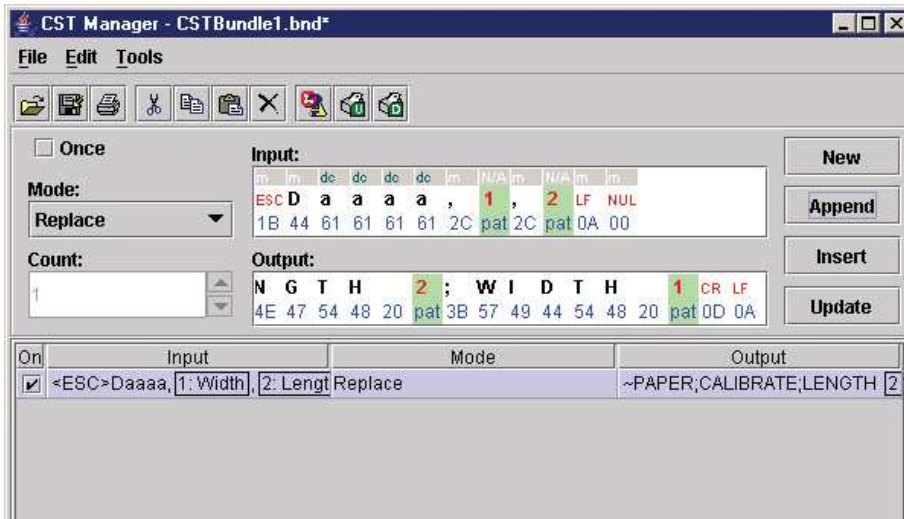

Figure 157 The Appended CST

34. Click **Append**. See Figure 157.

Now you will test the newly created CST.

35. Select **Tools** ► **Test**. The Test window opens. See Figure 158.

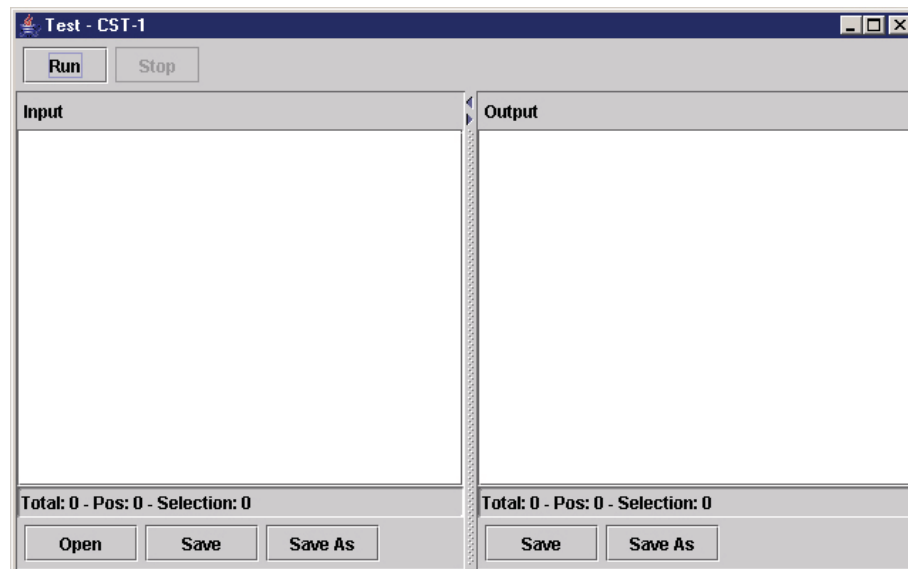

Figure 158 The Test Window

36. Right-click the Input window.

37. Select **View** ► **Hex**. To enter the Hex entry mode.

38. Click just to the right of the eight zeros to position the cursor.

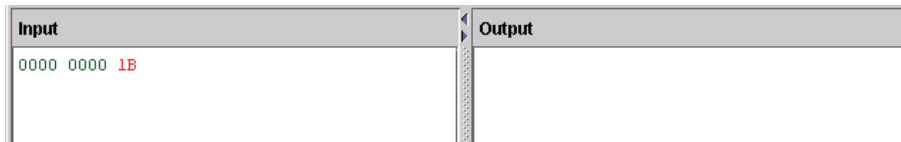

Figure 159 Hex Entry Mode

39. Type **1B**. To enter the hex equivalent of <ESC>. See Figure 159.

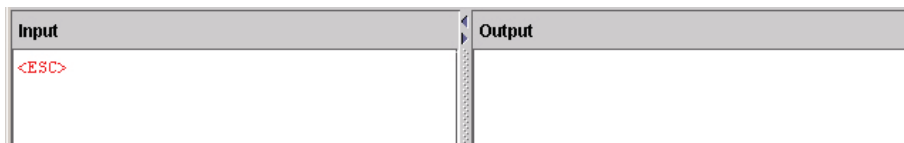

Figure 160 Mnemonics Entry Mode

40. Right-click the Input window and select **View ► Mnemonics**. To enter the Mnemonics entry mode. Notice the 1B changed to <ESC>. See Figure 160.

41. Type D0123,0450,0600.

42. Right-click the Input window and select **View ► Hex**.

43. Click just to the right of **0010** on the second line.

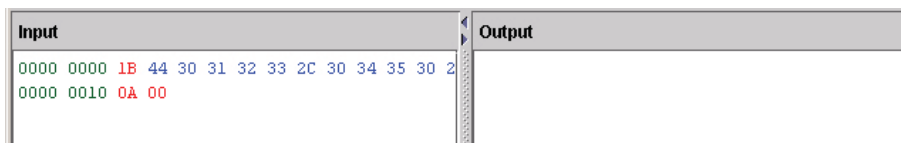

Figure 161 Hex Equivalents of LF and NUL

44. Type **0A00**. To enter the hex equivalent of LF and NUL. See Figure 161.

45. Right-click the Input window and select **View ► Mnemonics**.

46. Click **Run** to test the CST against your input.

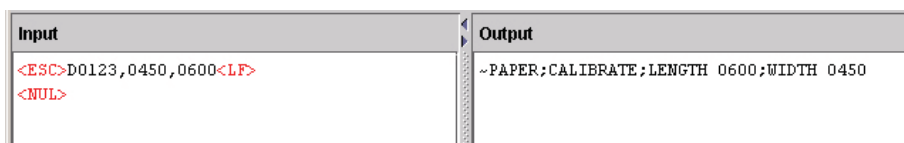

Figure 162 Successful CST Test Results

The length and width information have successfully been placed in the correct position in the PGL command. See Figure 162.

NOTE: If a value outside the specified range (in this case, outside the range 0..9) is entered, no conversion takes place and the input string is passed on to the printer unmodified.

Variable Tab

Use Variable tab to define variables. Use a variable to store data from the host so that it can be used at a later time. To define a variable, enter the name of the variable and add it to the Variable List. To store data into the variable use the Store mode (page 141). To clear the content of all defined variables use the Reset All Variables mode (page 141).

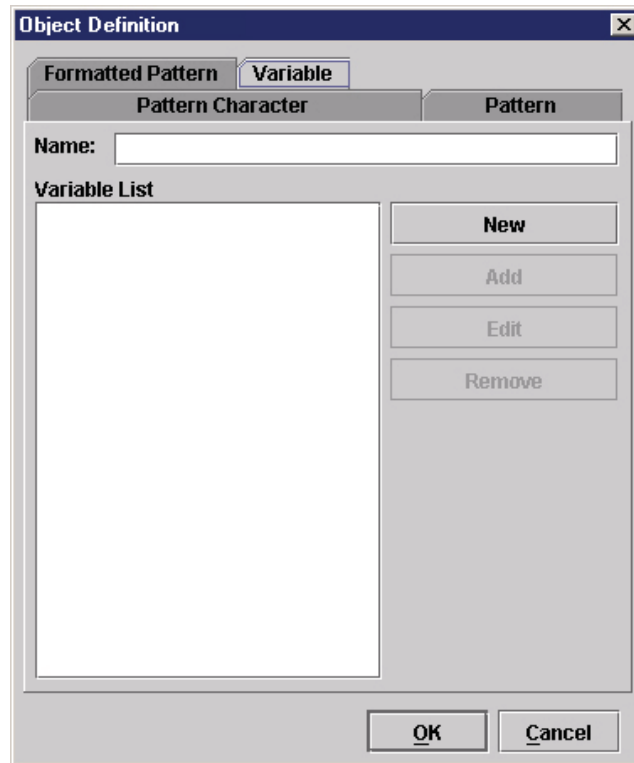

Figure 163 Variable Tab

Name: The name of the variable. This name appears in pop-up menus where you insert and use variables.

Variable List

Lists all the variables that you have defined and added to the list.

New: Click **New** to clear the Name field.

Add: Click **Add** to add the named variable to the end of the Variable List.

NOTE: The name of the variable must be unique.

Edit: Select an item in the Variable List, and click **Edit** to copy its name into the Name field.

NOTE: If you select more than one item, only the name of the first item will copy into the Name field.

Remove: Select one or more items in the Variable List, and click **Remove** to remove them from the list.

IMPORTANT Removing variables invalidates entries that use the variables.

Status Response Definition

The screenshot shows the 'Status Response Generator' dialog box. It features a 'Conditions' section with a list box, 'Name' and 'Output' text boxes, and 'New', 'Add', 'Edit', and 'Remove' buttons. The 'Status Bits' section includes radio buttons for 'Unconditional', 'Job In Process', 'Job Complete', and 'Wait Job Complete'. The 'Protocol' section has a list box, 'Name' text box, 'Interface' dropdown menu (set to 'Active'), and 'New', 'Add', 'Edit', and 'Remove' buttons. 'OK' and 'Cancel' buttons are at the bottom right.

Figure 164 Status Response Generator

Click **Status Response Definition**, and the Status Response Generator dialog box opens. See Figure 164.

Use the Status Response Generator to define status responses. You can define printer status bits that make up the condition on which a response should be generated, as well as the details of each response.

Conditions

Use the upper section of the Status Report Generator to add new conditions or select existing conditions to edit or remove.

Name: The name of the condition.

Output: The response for when the condition is met.

Status Bits

Unconditional: To create an unconditional protocol. When you select Unconditional, all other status bits are disabled.

NOTE: If you have already added other conditions, and then you later add a condition with the Unconditional Stop Bits property, all other conditions will be removed from the list.

Job Complete: To create a Job Complete condition.

Job In Process: To create a Job In Process condition.

NOTE: You cannot have more than one condition in the Conditions list with the same Status Bits setting.

Conditions List

Lists all the conditions that you have defined and added to the list. A condition is listed by its name followed by a separator and the output sequence. In the output sequence, control codes display as mnemonics and other non-printable characters display as red dots.

New: Click **New** to reset all data fields.

Add: If the displayed text on the second button is Add, the condition has not been added to the Conditions list. Click **Add** to add the defined condition to the end of the Conditions list.

Update: If the displayed text on the second button is Update, the condition is already in the Conditions list. Click **Update** to update the condition properties with the new properties.

Edit: Select an item in the Conditions list, and click **Edit** to edit it.

NOTE: If you select more than one item, you can only to edit the first item.

Remove: Select one or more items in the Conditions list, and click **Remove** to remove them from the list.

IMPORTANT Removing conditions invalidates entries that use the conditions.

Protocols

Use the lower section of the Status Report Generator to add new protocols or select existing protocols to edit or remove.

A protocol is a single condition or set of conditions.

Name: The name of the protocol. This name appears in pop-up menus where you insert and use protocols.

Interface: Use this drop-down list to select which (host) interface the response should go to. Active is the interface on which the CST operates.

Protocol List

New: Click **New** to reset the Name and Interface fields.

Add: If the text displayed on the second button is Add, the protocol has not been added to the Protocol list. Click **Add** to add the protocol to the Protocol list.

NOTE: The protocol appears in the list with its name followed by a separator and the name of the interface used.

Update: If the text displayed on the second button is Update, the protocol is already in the Protocol list. Click **Update** to update the protocol properties with the new properties.

Edit: Select an item in the Protocol list, and click **Edit** to edit it.

NOTE: If you select more than one item, you can only to edit the first item.

Remove: Select one or more items in the Protocol list, and click **Remove** to remove them from the list.

IMPORTANT Removing protocols invalidates entries that use the protocols.

How To Use Conditions And Protocols

After you define one or more protocols, return to the CST Manager to create a new entry available for editing. Select **Response** from the Mode drop-down list. In the Input field, enter the data on which the response should be triggered. Right-click the Output field, and select the desired protocol from the pop-up menu.

You can enter prefixes and suffixes, and these will be sent with the defined output of the protocol. For example, if the output is defined as **pre <Series-1> suf**, and the On_Empty condition is met, then **pre 1<CR> suf** will be the response.

A protocol displays with the protocol icon over a light red background with the mnemonic **ptc**. To see protocol details, i.e. name and interface, hover the pointer over the protocol icon in the Output field to display a screen tip. See Figure 165.

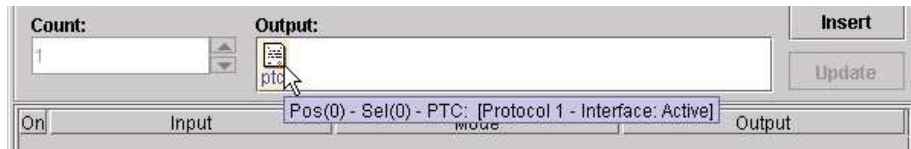

Figure 165 Protocol Screen Tip

Status Response Generator Example

A host computer sends out an ENQ character to request the printer's status. The host computer expects to receive an ACK character when the job has finished, or a NAK character if the printer is printing.

In the CST Manager, click **Status Response Definition**. The Status Response Generator dialog box opens. See Figure 166.

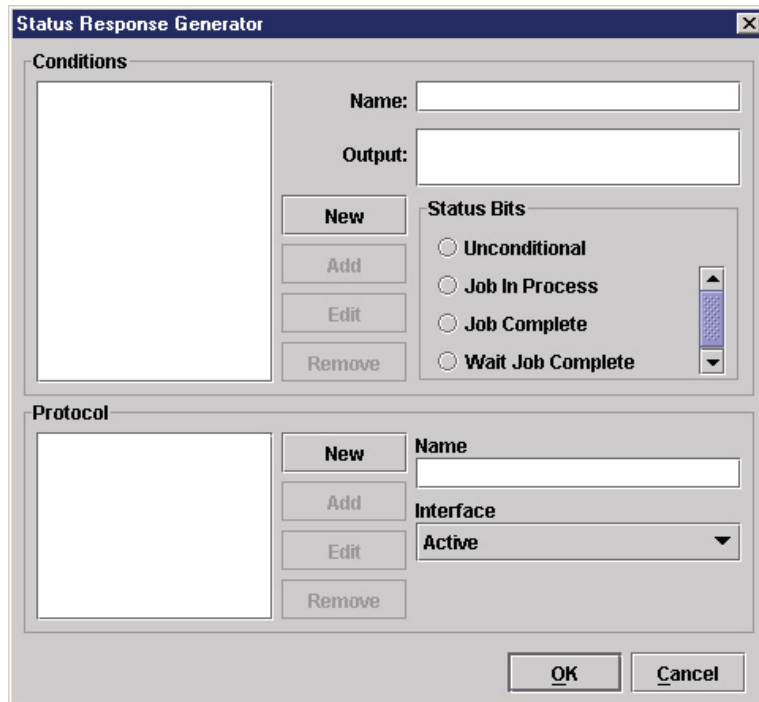

Figure 166 Status Response Generator

You can define the protocol conditions in the upper half of this window. This protocol, along with other available protocols, will be listed in the lower half. From this list, the correct protocol is selected during the creation of a CST.

NOTE: You must add protocol conditions before you can add a protocol. For now you will only define a single protocol.

1. Use a descriptive name for the first condition that should be tested. In the Name field, type `job_printing`.

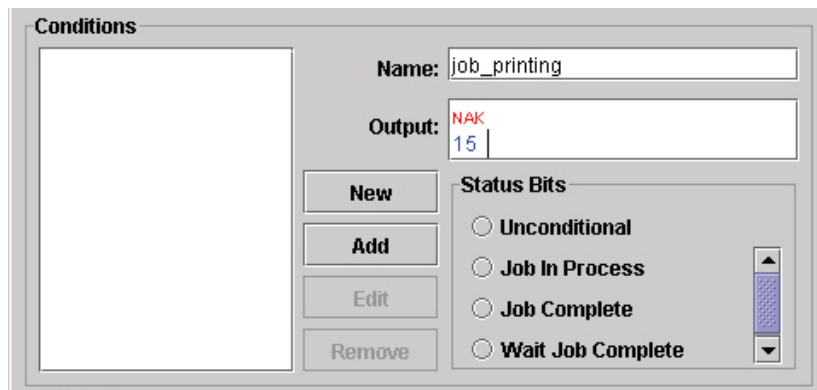

Figure 167 Switching Between ASCII and Hex Entry Modes

2. Define the output that should be transmitted to the host. In the Output field, press the down arrow key and type 15 (NAK). See Figure 167.

NOTE: Use the up and down arrow keys to switch between the ASCII and Hex entry modes.

3. Under Status Bits, click **Job In Process** to select the correct condition to test.

Here is a description of the Status Bits conditions:

- **Unconditional:** This condition is always TRUE. The response is sent to the host immediately.
- **Job Complete:** This condition is TRUE if the printer is not processing or printing any data. The response is sent to the host immediately but ONLY IF this condition is TRUE.
- **Job In Process:** This condition is TRUE if the printer is processing or printing data. The response is sent to the host immediately but ONLY IF this condition is TRUE.
- **Wait For Job Complete:** This condition is TRUE if the printer is not processing or printing any data. The response is sent to the host AS SOON AS this condition is TRUE.

4. Click **Add** to add the entry to the list of protocol conditions.

Now you will add a second condition.

5. In the Name field, type `job_done`.
6. In the Output field, press the down arrow key and type 06 (ACK).
7. Under Status Bits, click **Job Complete**.

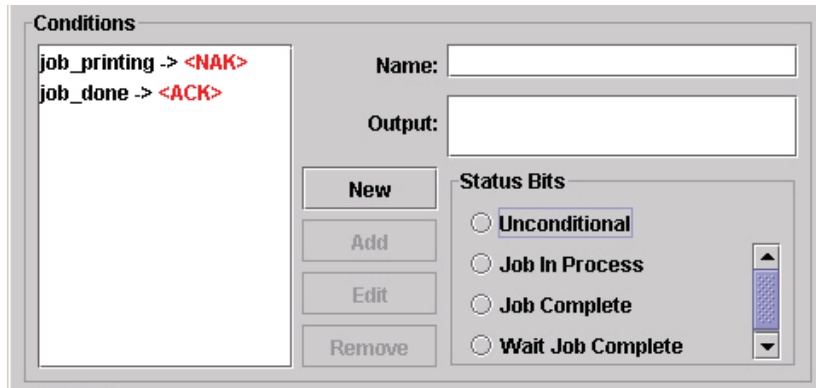

Figure 168 Adding Conditions

8. Click **Add** to add the entry to the list of protocol conditions. See Figure 168.
9. Name this protocol that is comprised of the two conditions. In the Name field (bottom half of window), type `print_complete`.
10. Select the interface to use for the status response. Click the Interface down arrow, and select **Active**.

NOTE: The interface selected does not have to be the same interface the host is using for a status request. The available interfaces are Active, Serial, Parallel, and Network.

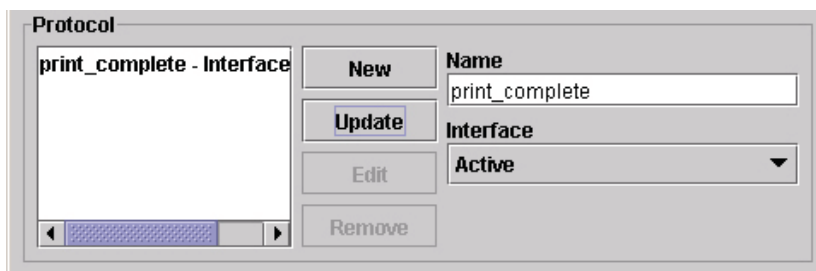

Figure 169 Adding Protocols

11. Click **Add** to add it to the list of protocols. See Figure 169.
12. Click **OK** to return to the CST manager.

NOTE: For the status reporting to work, the printer will have to be online.
Offline conditions, like all error situations, cannot be transmitted to the host.

Now you will enter the input string that will trigger the protocol you just created.

13. Click the **Mode** down arrow, and select **Response**.
14. In the Input field, press the down arrow key and type `05` (ENQ).

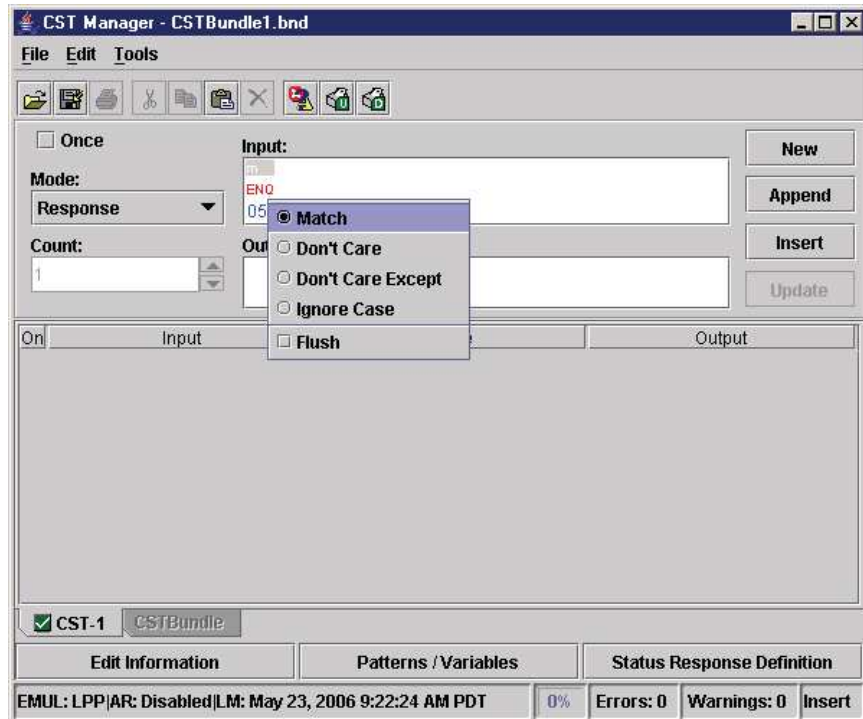

Figure 170 Response Mode Attributes

15. Right-click your input string. A list of possible attributes displays. See Figure 170.

NOTE: In addition to the four common attributes, Response mode has the Flush attribute. This attribute removes the input string from the datastream, preventing it from being printed.

16. Click away from the attributes to close the list.

17. Right-click the Output field to specify which protocol should be used when a status is requested. A list of protocols (in this case just one) displays.

18. Select print_complete.

19. Click **Append** to append it to the CST.

20. Select **File ► Save** or **File ► Save As** to save the bundle.

21. Download the bundle file to the printer.

22. Enable the CST in the printer.

The printer now has a status reporting protocol.

NOTE: The input string used to request the printer status does not have to be a single control code like the ENQ character. Likewise, the output does not have to be NAK or ACK. It can be anything that the host can transmit and handle.

It is possible to create a status reporting protocol that uses sentences. For example, replace the ENQ in the example with "Printer, how are you doing on this print job?" Replace the Job In Progress condition output with "I am almost done." Finally, replace the Job Complete condition output with "I have just finished this job."

CST Manager And EBCDIC

In addition to the standard ASCII character set commonly used for printing, many applications use the EBCDIC character set. The CST Manger is specifically designed to work with ASCII. To work with EBCDIC coded files, characters in the Input and Output strings need to be entered in their EBCDIC representation. Since the CST Manager does not have an EBCDIC view mode, these entries must be entered in hex.

EBCDIC/ASCII Table

To help in creating EBCDIC CSTs, refer to the following table for Twinax, Coax LU-1, Coax LU-3, and ASCII.

NOTE: For LU-3 in the following table: EM = End of Message, FF = Form Feed, NL = New Line, and CR = Carriage Return.

Hex	Mnemonic	EBCDIC		Hex	Mnemonic	ASCII
		Twinax/LU-1	LU-3			
00	NUL	Null	Null	00	NUL	Null
01	SOH	Start of Header	EM	01	SOH	Start of Header
02	STX	Start of Text	FF	02	STX	Start of Text
03	ETX	End of TEXT	NL	03	ETX	End of Text
04	PF	Punch Off		04	EOT	End of Transmission
05	HT	Horizontal Tab	CR	05	ENQ	Enquiry
06	LC	Lower Case		06	ACK	Acknowledge
07	BEL	Delete		07	BEL	Bell
08			>	08	BS	Backspace
09			<	09	HT	Horizontal Tab
0A	SMM	Start of Man. Message	¢	0A	LF	Line Feed
0B	VT	Vertical Tab	!	0B	VT	Vertical Tab
0C	FF	Form Feed)	0C	FF	Form Feed
0D	CR	Carriage Return	(0D	CR	Carriage Return
0E	SO	Shift Out	}	0E	SO	Shift Out
0F	SI	Shift In	{	0F	SI	Shift In
10	DLE	Data Link Escape	SP	10	DLE	Data Link Escape
11	DC1	Device Control 1	=	11	DC1	Device Control 1
12	DC2	Device Control 2	'	12	DC2	Device Control 2
13	TM	Tape mark	"	13	DC3	Device Control 3
14	RES	Restore	/	14	DC4	Device Control 4
15	NL	New Line	\	15	NAK	Neg. Acknowledge

Hex	Mnemonic	EBCDIC		Hex	Mnemonic	ASCII
		Twinax/LU-1	LU-3			
16	BS	Back space		16	SYN	Synchronous Idle
17	IL	Idle		17	ETB	End of Transm. Block
18	CAN	Cancel	?	18	CAN	Cancel
19	EM	End of Medium	!	19	EM	End of Medium
1A	CC	Cursor Control	\$	1A	SUB	Substitute
1B	CU1	Customer Use 1	¢	1B	ESC	Escape
1C	IFS	Interch. File Separator		1C	FS	File Separator
1D	IGS	Interch. Grp Separator		1D	GS	Group Separator
1E	IRS	Interch. Rec. Separator	\$	1E	RS	Record Separator
1F	IUS	Interch. Unit Separator		1F	US	Unit Separator
20	DS	Digit Select	0	20	SP	Space
21	SOS	Start of Significance	1	21	!	Exclamation point
22	FS	Field Separator	2	22	"	Quotation Mark
23			3	23	#	Number Sign
24	BYP	Bypass	4	24	\$	Dollar sign
25	LF	Line Feed	5	25	%	Percent
26	ETB	End of Transm. Block	6	26	&	Ampersand
27	ESC	Escape	7	27	'	Apostrophe
28			8	28	(Left Parenthesis
29			9	29)	Right Parenthesis
2A	SM	Set Mode		2A	*	Asterisk
2B	CU2	Customer Use 2	-	2B	+	Plus Sign
2C			#	2C	,	Comma
2D	ENQ	Enquiry	@	2D	-	Minus Sign
2E	ACK	Acknowledge	%	2E	.	Period
2F	BEL	Bell	_	2F	/	Slash
30			&	30	0	Zero
31				31	1	One
32	SYN	Synchronous Idle	.	32	2	Two
33			,	33	3	Three
34	PN	Punch On	:	34	4	Four
35	RS	Reader Stop	+	35	5	Five

Hex	Mnemonic	EBCDIC		Hex	Mnemonic	ASCII
		Twinax/LU-1	LU-3			
36	UC	Upper Case	¬	36	6	Six
37				37	7	Seven
38				38	8	Eight
39				39	9	Nine
3A				3A	:	Colon
3B	CU3	Customer Use 3	~	3B	;	Semicolon
3C	DC4	Device Control 4	~	3C	<	Less-than Sign
3D	NAK	Negative Acknowledge	`	3D	=	Equal Sign
3E				3E	>	Greater-than Sign
3F	SUB	Substitute		3F	?	Question Mark
40	SP	Space		40	@	At Sign
41				41	A	A
42				42	B	B
43				43	C	C
44				44	D	D
45				45	E	E
46				46	F	F
47				47	G	G
48				48	H	H
49				49	I	I
4A	¢	Cent Sign		4A	J	J
4B	.	Period		4B	K	K
4C	<	Less-than Sign		4C	L	L
4D	(Left Parenthesis		4D	M	M
4E	+	Plus sign		4E	N	N
4F		Logical Or		4F	O	O
50	&	Ampersand	“	50	P	P
51				51	Q	Q
52				52	R	R
53			¢	53	S	S
54			!	54	T	T
55				55	U	U

Hex	Mnemonic	EBCDIC		Hex	Mnemonic	ASCII
		Twinax/LU-1	LU-3			
56				56	V	V
57				57	W	W
58				58	X	X
59				59	Y	Y
5A	!	Exclamation Point		5A	Z	Z
5B	\$	Dollar Sign		5B	[Opening Bracket
5C	*	Asterisk		5C	\	Back Slash
5D)	Right Parenthesis		5D]	Closing Bracket
5E	;	Semicolon		5E	^	Caret
5F	-	Logical NOT		5F	_	Underline
60	-	Minus Sign		60	`	Grave Accent
61	/	Slash		61	a	a
62				62	b	b
63				63	c	c
64				64	d	d
65				65	e	e
66				66	f	f
67				67	g	g
68				68	h	h
69				69	i	i
6A				6A	j	j
6B	,	Comma		6B	k	k
6C	%	Percent		6C	k	k
6D	_	Underline		6D	m	m
6E	>	Greater-than Sign		6E	n	n
6F	?	Question Mark		6F	o	o
70			#	70	p	p
71				71	q	q
72				72	r	r
73			@	73	s	s
74			\$	74	t	t
75				75	u	u

Hex	Mnemonic	EBCDIC		Hex	Mnemonic	ASCII
		Twinax/LU-1	LU-3			
76				76	v	v
77				77	w	w
78				78	x	x
79				79	y	y
7A	:	Colon		7A	z	z
7B	#	Number Sign		7B	{	Opening Brace
7C	@	At Sign		7C		Vertical Line
7D	'	Apostrophe		7D	}	Closing Brace
7E	=	Equal Sign		7E	~	Tilde
7F	"	Quotation Mark	#	7F	DEL	Delete
80			a	80		
81	a	a	b	81		
82	b	b	c	82		
83	c	c	d	83		
84	d	d	e	84	IND	Index
85	e	e	f	85	NEL	Next Line
86	f	f	g	86	SSA	Start of Selected Area
87	g	g	h	87	ESA	End of Selected Area
88	h	h	i	88	HTS	Horz. Tabulation Set
89	i	i	j	89	HTJ	Horz. Tab w. Justif.
8A			k	8A	VTS	Vertical Tabulation Set
8B			l	8B	PLD	Partial Line Down
8C			m	8C	PLU	Partial Line Up
8D			n	8D	RI	Reverse Index
8E			o	8E	SS2	Single Shift 2
8F			p	8F	SS3	Single Shift 3
90			q	90	DCS	Device Control String
91	j	j	r	91	PU1	Private Use 1
92	k	k	s	92	PU2	Private Use 2
93	k	k	t	93	STS	Set Transmit State
94	m	m	u	94	CCH	Cancel character
95	n	n	v	95	MW	Message Waiting

Hex	Mnemonic	EBCDIC		Hex	Mnemonic	ASCII
		Twinax/LU-1	LU-3			
96	o	o	w	96	SPA	Start of Protected Area
97	p	p	x	97	EPA	End of Protected Area
98	q	q	y	98		
99	r	r	z	99		
9A			"	9A		
9B			¢	9B	CSI	Control Seq. Introducer
9C			!	9C	ST	String Terminator
9D				9D	OSC	Operating System Cmd.
9E			;	9E	PM	Privacy Message
9F			*	9F	APC	Applic. Program Cmd.
A0			A	A0		
A1			B	A1		
A2	s	s	C	A2		
A3	t	t	D	A3		
A4	u	u	E	A4		
A5	v	v	F	A5		
A6	w	w	G	A6		
A7	x	x	H	A7		
A8	y	y	I	A8		
A9	z	z	J	A9		
AA			K	AA		
AB			L	AB		
AC			M	AC		
AD			N	AD		
AE			O	AE		
AF			P	AF		
B0			Q	B0		
B1			R	B1		
B2			S	B2		
B3			T	B3		
B4			U	B4		

Hex	Mnemonic	EBCDIC		Hex	Mnemonic	ASCII
		Twinax/LU-1	LU-3			
B5			V	B5		
B6			W	B6		
B7			X	B7		
B8			Y	B8		
B9		Grave Accent	Z	B9		
BA			#	BA		
BB			@	BB		
BC			\$	BC		
BD				BD		
BE			;	BE		
BF			*	BF		
C0				C0		
C1	A	A		C1		
C2	B	B		C2		
C3	C	C		C3		
C4	D	D		C4		
C5	E	E		C5		
C6	F	F		C6		
C7	G	G		C7		
C8	H	H		C8		
C9	I	I		C9		
CA				CA		
CB				CB		
CC				CC		
CD				CD		
CE				CE		
CF				CF		
D0				D0		
D1	J	J		D1		
D2	K	K		D2		
D3	L	L		D3		
D4	M	M		D4		

Hex	Mnemonic	EBCDIC		Hex	Mnemonic	ASCII
		Twinax/LU-1	LU-3			
D5	N	N		D5		
D6	O	O		D6		
D7	P	P		D7		
D8	Q	Q		D8		
D9	R	R		D9		
DA				DA		
DB				DB		
DC				DC		
DD				DD		
DE				DE		
DF				DF		
E0				E0		
E1				E1		
E2	S			E2		
E3	T			E3		
7E4	U			E4		
E5	V			E5		
E6	W			E6		
E7	X			E7		
E8	Y			E8		
E9	Z			E9		
EA				EA		
EB				EB		
EC				EC		
ED				ED		
EE				EE		
EF				EF		
F0	0	Zero		F0		
F1	1	One		F1		
F2	2	Two		F2		
F3	3	Three		F3		
F4	4	Four		F4		

Hex	Mnemonic	EBCDIC		Hex	Mnemonic	ASCII
		Twinax/LU-1	LU-3			
F5	5	Five		F5		
F6	6	Six		F6		
F7	7	Seven		F7		
F8	8	Eight		F8		
F9	9	Nine		F9		
FA				FA		
FB				FB		
FC				FC		
FD				FD		
FE				FE		
FF				FF		

CST Manager Version Control System

The Version Control System (VCS) allows you to assign an application name and add version information to the files. This information helps you easily identify the purpose of the files created and in which application. The VCS prints the application name and version information in the printer's configuration printout.

Application Name and Version Information

The application name is a logical user-defined name for the CST application and is stored inside the CST Configuration file. The maximum length is 16 characters.

The version information contains the following:

- **Version Number** – V<version>.<revision><release level>

where:

<version> = decimal number (1 ... n)

<revision> = decimal number (two digits: 00 ... 99)

<release level> = upper-case alphabetic character (A ... ZZ)

Examples: V1.00A (initial version), V2.06C, V3.21AA, V3.21BX.

- **Last Modification Date** - <month> - <day> - <year>

Indicates when the PAA CST File was last modified.

- **File ID** – Unique 32-bit hexadecimal number (checksum).

NOTE: The VCS system cannot prevent the creation of two files that contain the same application name and version information but different content. To help identify such similar files, the Manager will include a checksum in the file.

Both the version number and last modification date are stored in the respective configuration file.

Creating a New File

When creating and saving a file for the first time, the Set Application Name dialog box opens prompting you to enter a logical name to identify the application.



Figure 171 Setting the CST Application Name

Opening an Existing File

When you select File -> Open, or upload a file from the printer, the VCS checks if the file contains version information. If not, a dialog box opens and prompts you to enter a logical application name. The version number is set to 1.00A. You can then start modifying the application.

Modifying an Existing File

After opening an existing file, the process of building and modifying the application starts. To save your work as a new file or subsequent modifications of an existing file, do the following:

- Save As New File

Select File -> Save As. The application name is already assigned and the version number is 1.00A. Select a folder name, enter a file name, and click Save. The file is then stored on disk.

- Subsequent Saves

Select File -> Save. The Version Confirmation dialog box opens with save options. See Figure 172.

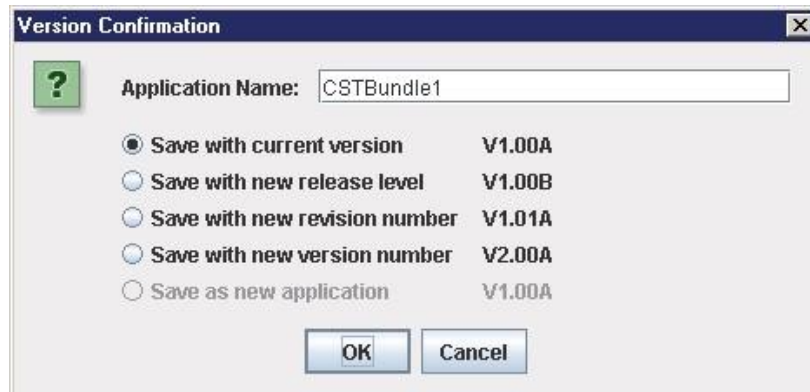

Figure 172 Confirming the File Version

NOTE: If you do not change the application name, the 'Save as new application' option is disabled. In this case, you must select one of the first four options. 'Save with current version' is the default selection.

If you change the application name, 'Save as new application' is enabled, allowing you to reset the version number to 1.00A.

The version numbers displayed with the options are the version numbers the CST Manager will store in the file.

NOTE: Version number increment rules.

When a file reaches release level Z and you select 'Save with new release level', the release level increments to AA. For example, 1.01Z becomes 1.01AA.

When the release level reaches ZZ and the you select 'Save with new release level', the release level resets to A and the revision number increments. For example, 1.01ZZ becomes 1.02A.

When the revision number reaches 99 and you select 'Save with new revision number', the revision number resets to 00, the release level resets to A, and the version number increments. For example, 1.99C becomes 2.00A.

Viewing File Version Information

To view version information of a file, select File -> Properties.



Figure 173 Viewing File Properties

Automatic File Backup System

The CST Manager automatically creates backups of the last 20 saved versions of a file. This backup system uses the file name (as specified in the File Save As ... dialog) to create the following file and folder structure:

< jav.user.dir\backup > - the java user directory is the PNE Auto ID install directory.

< File Name > - folder that will store the backups.

< ~ddmmyyyy_hhmmss>.bck - backup of the latest previous version of a file.

< ~ddmmyyyy_hhmmss>.bck - backup of the second latest previous version of a file

...

< ~ddmmyyyy_hhmmss>.bck - backup of the oldest previous version of the file.

Example:

File name = 'PTNX_SecurePrinting.gcf

< jav.user.dir\backup >

PTNX_SecurePrinting

~11042008_123145.bck

~11042008_124432.bck

...

~11042008_145022.bck

Backup History

The CST Manager has a Backup History option that allows you to view the backup history of a file. The system maintains the last 20 versions of the file. This dialog has options to clear the history, open an older version, and save under a different file name.



Name	Version	Checksum	Date	Time	Notes
_TestApp	V1.00A	1A7DC35A	22 Apr 2008	11:36:33	Created on save by GPI
_TestApp	V1.00A	CDE72AB9	22 Apr 2008	11:36:16	Created on save by GPI
_TestApp	V1.00A	E959FB8D	22 Apr 2008	11:36:01	Created on save by GPI
_TestApp	V1.00A	321C4A6B	22 Apr 2008	11:35:46	Created on save by GPI
_TestApp	V1.00A	143DAC4D	22 Apr 2008	11:35:37	Created on save by GPI
_TestApp	V1.00A	963EBFF7	22 Apr 2008	11:27:20	Created on save by GPI
_TestApp	V1.00A	1A7DC35A	22 Apr 2008	11:11:09	Created on save by GPI
_TestApp	V1.00A	E959FB8D	22 Apr 2008	11:10:12	Created on save by GPI
_TestApp	V1.00A	26F50315	22 Apr 2008	11:09:59	Created on save by GPI
_TestApp	V1.00A	1A7DC35A	22 Apr 2008	10:52:13	Created on save by GPI
_TestApp	V1.00A	1EDF0811	22 Apr 2008	10:38:24	Created on save by GPI
_TestApp	V1.00A	66F82EDF	22 Apr 2008	09:46:11	Created on save by GPI
Events-01	V1.00A	8C3AB8CB	16 Apr 2008	11:03:26	Created on save by GPI

Figure 174 Backup History Information

- Name - displays the application name assigned to the file at the time the backup was created.
- Version - displays the version assigned to the file at the time the backup was created.
- Checksum - displays the checksum calculated over the data of the file at the time the backup was created.
- Data and Time - shows when the backup file was created.
- Notes - displays which version of the CST manager the backup file was created.
- Clear button - clears the history.
- Open button - opens the backup file for editing.
- Save As button - saves a backup file under a different name to a local storage medium.
- Close button - closes the dialog.

6 *GPIO Manager*

Introduction

This chapter describes the Printronix Auto ID GPIO function available for the Printronix Auto ID T5000, T6000 and T8000 Thermal printers.

GPIO is both hardware and software. The hardware is the I/O board to be mounted in the printer, and the software is the GPIO Manager. The GPIO hardware is a printed circuit board containing optically isolated inputs and outputs as well as relays. The GPIO software is both a printer resident GPIO event parser and a PC-based GPIO manager that allows the user to define how the general purpose I/O hardware should behave for the given application.

NOTE: Certain GPIO features in T5000 printers can only be enabled by a special security key, described in Table 9 on page 191 and Table 10 on page 200. On T6000 and T8000 all GPIO features are standard.

Events and Actions

GPIO operation is based on Events and Actions. Events can be either printer internal such as paper out or print complete, or they can be printer external such as opto-coupler 1 active. Actions are the result of an event and can be printer internal such as paper feed or printer external such as relay 1 active or reply to host where data is transmitted over the serial, parallel, or network interface. You can also define a number of events to be acted upon without the GPIO card installed in the printer and allow the printer to be adapted for the application in use.

The Hardware

The GPIO hardware (Figure 175) consists of 16 opto-couplers, 4 SPDT relays, and the logic required to connect this hardware into the printing system.

Eight of the 16 opto-couplers are used as isolated inputs; these are the connections on which the external events happen. The remaining eight opto-couplers and the four SPDT relays are used as isolated outputs. Each of these outputs can be designated as an action in response to some event. The board is connected into the printing system through the printer's PCI bus.

None of the inputs or outputs is connected to any voltage source; it is the user's responsibility to make those connections. A separately fused 5 volt and a separately fused 24 volt are available on the 50 pin connector in which all inputs and outputs are terminated.

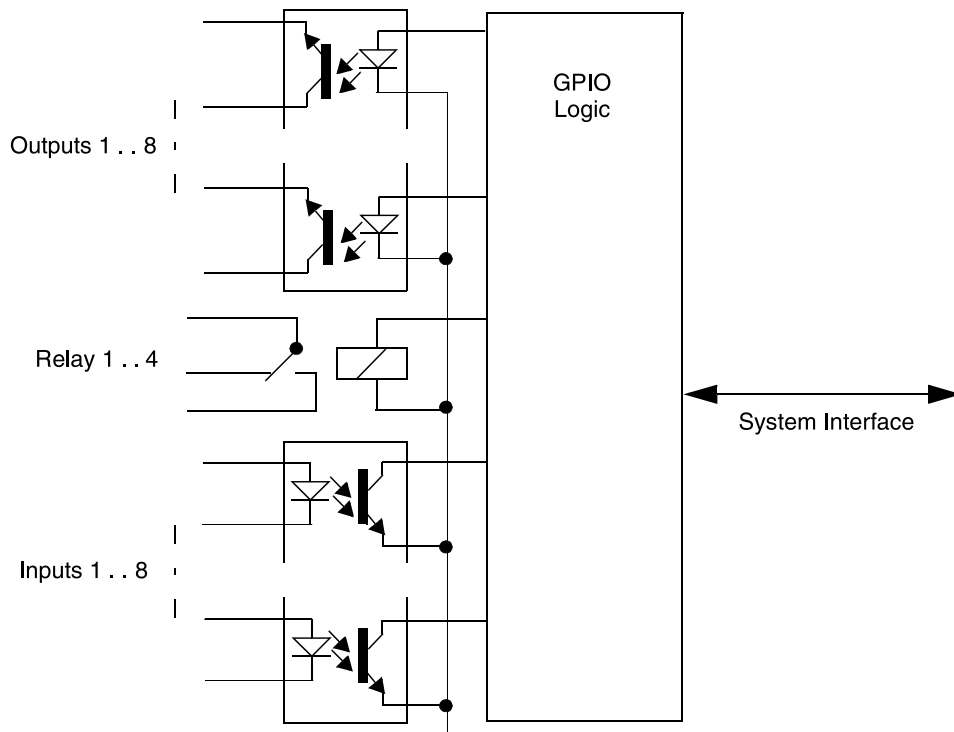

Figure 175 GPIO Hardware

Overview

To launch the GPIO Configuration Manager, select **Applications ► GPIO Manager**.

The screen in Figure 176 displays. The fields on this screen are described in detail on the following pages.

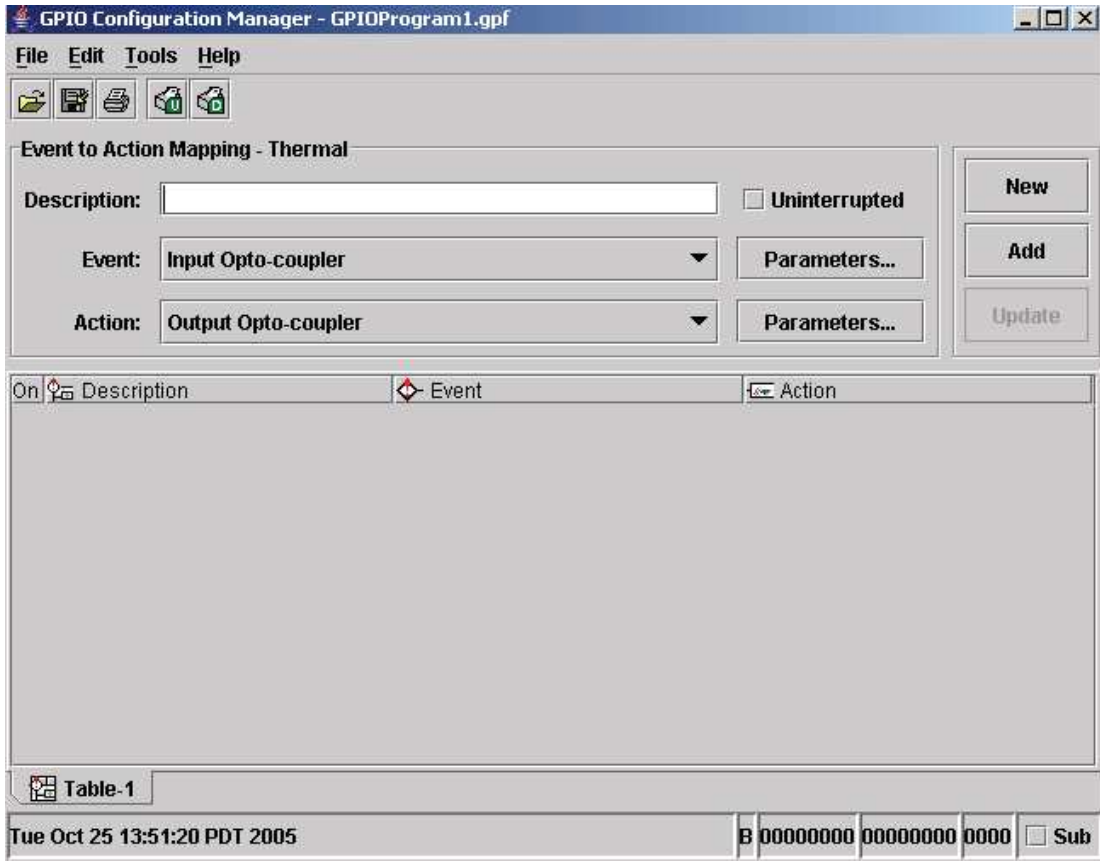

Figure 176 The GPIO Configuration Manager

The Toolbar And Menus

The toolbars allow the handling of files and text.

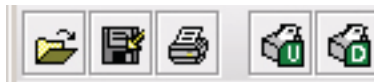

Figure 177 The GPIO Configuration Manager Toolbar

File

The File menu allows you to create, open, reopen, save a new or existing GPIO program file, or print GPIO configurations.

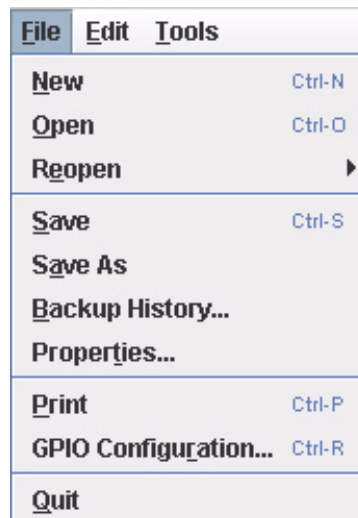

Figure 178 The File Menu

The Print option allows the mapping table to be printed for later reference. When you select File ► Print, the GPIO Print Setup dialog box opens allowing you to specify the desired print job. See

Figure 179.

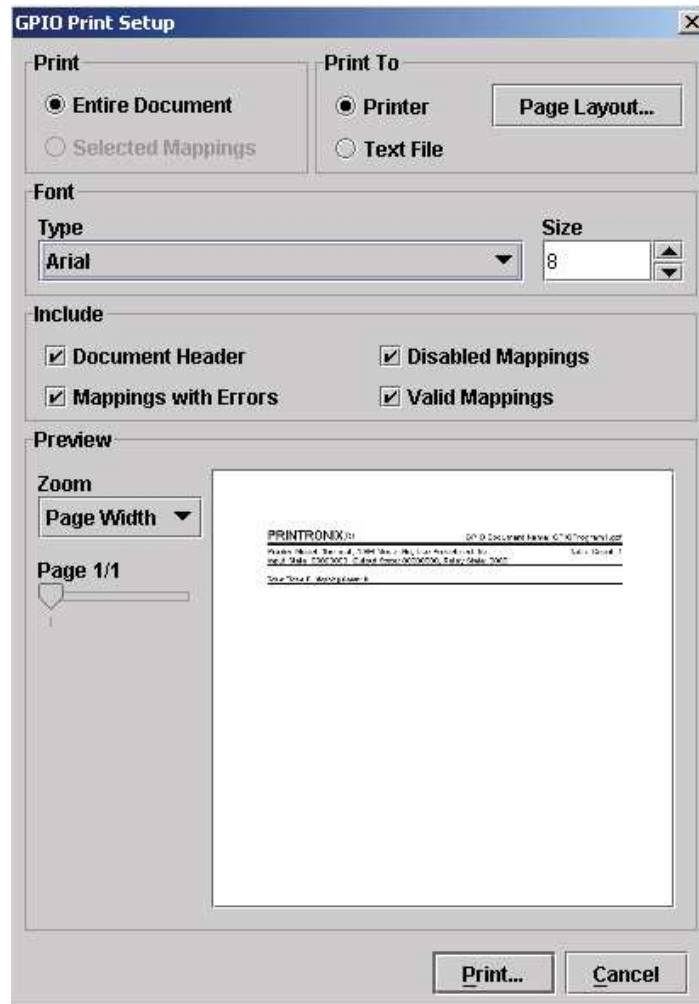

Figure 179 The GPIO Print Setup Dialog Box

When you select **File ► GPIO Configuration** the GPIO Configuration dialog box opens. This allows you to define the GPIO properties and power-up settings.



Figure 180 The GPIO Configuration Dialog Box

The Properties tab allows you to select the type of printer, either Thermal or Impact, for which the mapping table will be designed. For security, the password field allows you to password protect a mapping table.

NOTE: Password protected files can be uploaded to the GPIO manager but cannot be edited or downloaded to a printer without the password.

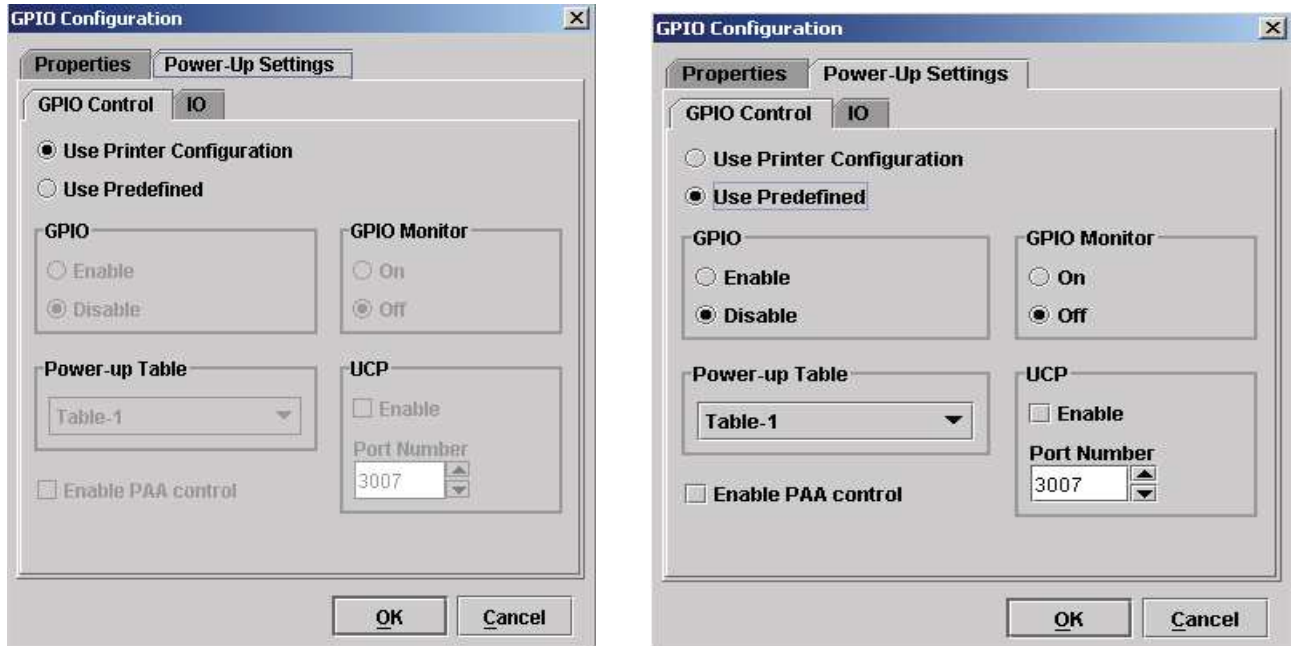

Figure 181 Power-Up Settings – GPIO Control Tab

Within the Power-Up Settings tab are two tabs, GPIO Control and IO.

NOTE: Settings made GPIO Control and IO predefining the output levels of GPIO will only be functional when the advanced GPIO features are enabled in the printer.

The GPIO Control tab allows the specification of the GPIO power-on configuration. This can be either the printer configuration or a predefined one. If “Use Printer Configuration” is selected, initial GPIO settings will be as specified in the Printer Power-On Configuration. See Figure 181.

If “Use Predefined” is selected, you can specify the following options:

- GPIO – Enable or disable the GPIO at power-on.
- GPIO Monitor – Switches the GPIO monitor on or off. The GPIO monitor is the reflection of the opto-coupler inputs in the lower line of the LCD.
- Power-Up Table – specifies the mapping table to use following power-on.
- UCP – Universal Control Port is an offline available TCP port. To enable the UCP port, check mark the Enable option.
- Enabling the UCP port disables the PXML port.
- Enable PAA Control – When enabled, PAA control matches from the active CST table is reported to GPIO by the Data Field Changed event. The predefined data field PAA State is used to generate the event. GPIO can check this data field for changes. See Data Field Events on page 214. PAA delays further data processing until GPIO acknowledges the event. GPIO acknowledges the event by setting the PAA State field to either NACK or ACK. When GPIO replies with NACK, PAA ignores the match and sends the data to the emulation it is bound to. When GPIO replies with ACK, PAA executes the match as defined in the CST.

NOTE: GPIO does not always acknowledge the PAA trigger. If you use this feature, make sure the event is always acknowledged.

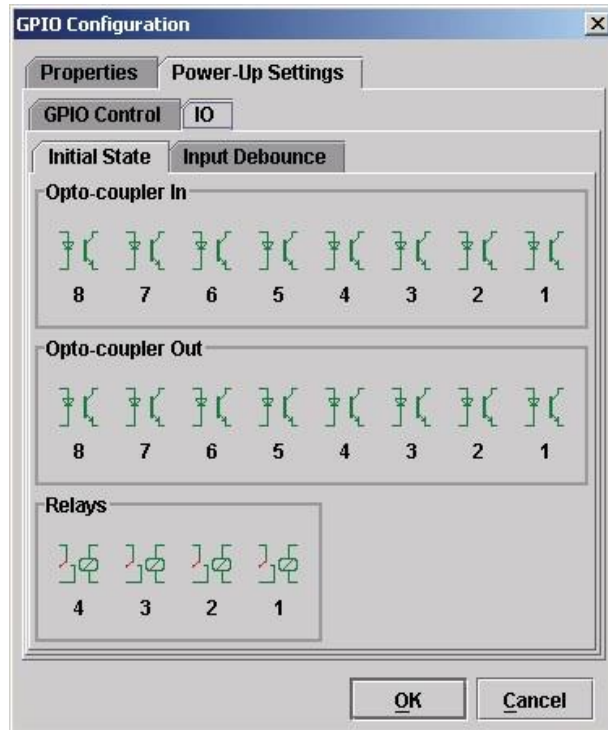

Figure 182 Power-Up Configuration – IO Tab, Initial State

The Power-Up Settings – IO tab contains two tabs, Initial State and Input Debounce.

Initial State

Divided into three sections, this panel is used to define the initial state of the GPIO board.

- **Opto-coupler In**

This section has 8 icons, each representing a single input Opto-coupler. An active icon means that the Opto-coupler will be active when the printer is powered on. If an event is assigned to the Opto-coupler and its power up state does not match its initial state, the action mapped to the event will be performed at power up.

NOTE: This only applies to opto coupler events defined by the selected power-up table. Click the icon to toggle the state.

- **Opto-coupler Out**

This section has 8 icons, each representing a single output Opto-coupler. An active icon means that the Opto-coupler will be active when the printer is powered on. Click the icon to toggle the state.

- **Relay**

This section has 8 icons, each representing a single output relay. An active icon means that the relay will be active when the printer is powered on. Click the icon to toggle the state.

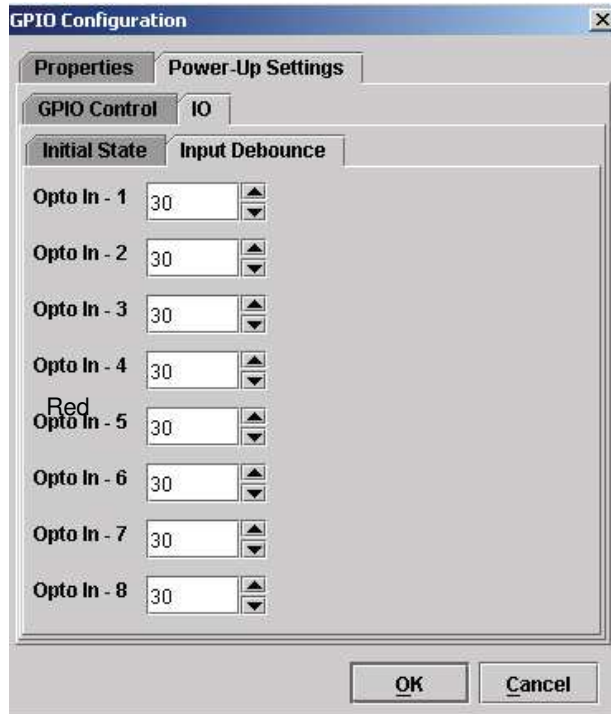

Figure 183 Power-Up Configuration – IO Tab, Input Debounce

Input Debounce

When using mechanical switches it is possible that more than one event is generated due to multiple contact detections. The solution to this undesired effect is debouncing. Debouncing waits a specific amount of time after the first contact has been detected before responding to the next contact.

Printer firmware that supports debouncing will apply a 30ms default debounce time. However if this value is not enough for some mechanical and digital switches such as optical sensors, debouncing may not be needed.

You can change the 30ms default value by setting a debounce time for each input. Simply adjust the debounce time in steps of 1ms; a setting of 0 (zero) means that debounce will be disabled. The maximum debounce value 65535.

Edit

The Edit menu allows you to define, delete, and rename mapping tables. You can also define data fields and reports to customize a mapping table. New mapping tables can be added to the tables that will be downloaded to the printer and existing mapping tables can be deleted or renamed.



Figure 184 The Edit Menu

Tools

The Tools menu allows you upload a mapping table from the printer and to download a mapping table to the printer. You also have the option to select the last selected upload printer or the last selected download printer. This option allows you to quickly select a printer previously used for uploading or downloading without having to go to the RMS printer database for your selection.

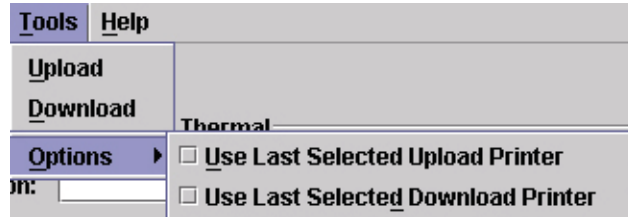

Figure 185 The Tools Menu

Help

The About option provides basic information about the GPIO Configuration Manager as seen in the startup splash screen.

Event To Action Mapping



Figure 186 Event To Action Mapping

Setting the criteria for mapping tables takes place in the Event to Action Mapping section (see Figure 186). The Description field allows you can enter a descriptive name to indicate the use of the event and its related action.

NOTE: The window header indicates which printer type (thermal or line matrix) the mapping table is created for. Figure 186 indicates a Thermal printer.

The Event and Action drop down menus allow you to select an event and apply an action to the selected event. Table 9 on page 191 lists the events currently available in the software.

The Event Parameters button allows you to select additional conditions related to the event (Figure 187).

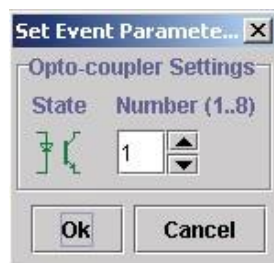

Figure 187 Setting Event Parameters

The Action drop down menu allows you to select the action that is to be taken on the specified event. Table 10 on page 200 lists the actions currently available in the software.

The Action Parameter button allows you to select additional conditions related to the action. Figure 188 displays parameters for the Output Opto-coupler and Output Relay actions.

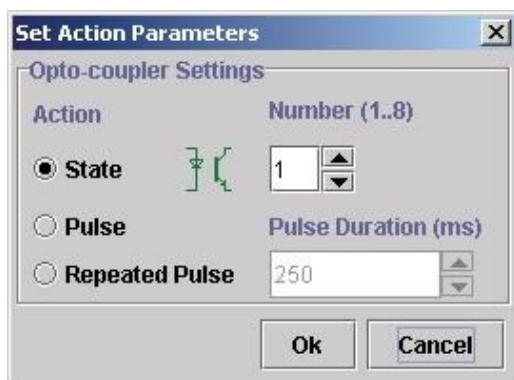

Figure 188 Setting Action Parameters

Events

Table 9 lists the available events and the related parameters. Events parameters are available for the Input Opto-Couplers, Panel Key Pressed events, Printer Error and Warning events (including RFID and ODV related errors), and PAA events (related to Data fields and Timers).

Table 9 Events And Parameters

Event Name	Description	Parameters	Security Key Required
Input Opto-Coupler	Events generated by the GPIO input Opto-Couplers.	Opto-Coupler Number (1..8), Active, Inactive	
Status Events			
Printer Powered Up	Events generated by the printer when the printer is powered on and ready to print.	None	
Printer Online	Event generated by the printer when the printer goes online.	None	
Printer Offline	Event generated by the printer when the printer goes offline.	None	
Printer Paused	Event generated by the printer when the printer enters Pause mode.	None	
Power Save Mode Entered	Event generated by the printer when the printer enters Power Save Mode.	None	
Power Save Mode Exited	Event generated by the printer when the printer exits Power Save Mode.	None	

Table 9 Events And Parameters

Event Name	Description	Parameters	Security Key Required
Data Controller Events			
Start Data Processing	Event generated by the printer when the printer starts processing data.	None	
End Data Processing	Event generated by the printer when the printer ends processing data.	None	
Printer Buffers Empty	Event generated by the printer when the printer buffers becomes empty.	None	
Engine Controller Events			
Single Label Printing, Enabled ¹	Event generated by the printer when single label printing is enabled.	None	✓
Single Page Printing, Enabled ²	Event generated by the printer when single page printing is enabled.	None	✓
Single Label Printing, Disabled ¹	Event generated by the printer when continuous label printing is disabled.	None	✓
Single Page Printing, Disabled ²	Event generated by the printer when continuous page printing is disabled.	None	✓
Label Pending ¹	Event generated by the printer when a label is waiting to be printed.	None	
Started Printing	Event generated by the printer when the printer starts printing.	None	
Label Printing	Even generated by the printer when a label is printing.	Normal, Overstrike RFID, Test, Overstrike ODV, Overstrike Manual	
Ended Printing	Event generated by the printer when the printing has ended.	None	
Started Paper Move	Event generated by the printer when the printer starts moving the paper.	None	
Label Printed ¹	Event generated by the printer when a label has printed.	Normal, Overstrike RFID, Test, Overstrike ODV, Overstrike Manual	
Overstrike Pending ¹	Event generated by the printer when a label overstrike is pending.	RFID, ODV, Manual	Only when parameter is ODV or Manual
Label Completed ¹	Event that is generated by the printer when a label is completed.	None	✓

Table 9 Events And Parameters

Event Name	Description	Parameters	Security Key Required
Label Rejected ¹	Event that is generated by the printer when a label is rejected.	None	✓
Label Canceled ¹	Event that is generated by the printer when a label is canceled.	None	✓
Label Failed	Event generated by the printer when a label failed to print.	None	✓
Label Present ¹	Event generated by the printer when the printer has a label printed and is waiting for the label to be taken.	None	
Label Taken ¹	Event generated by the printer when the label is taken.	None	
Page Printed ²	Event is generated by the printer when a page is printed.	None	
Labels Pending, None	Event is generated by the printer when the printer has no more pending labels to be printed.	None	✓
End Paper Move	Event generated by the printer when the printer ends moving the printer.	None	
Cutter Cycled	Event generated by the printer when the cutter cycle is completed.	None	
Sensor Event	Event generated by the printer when the action to set the sensor to ignored on or off, either is executed or failed.	Sensor Type, Event Type	✓
Errors/Warnings			
Printer Error	Events generated by the printer when errors occur or are cleared.	Paper Jam, Paper Out/Empty, Ribbon out, Print Head Open, TOF Detect Fault, RFID Tag Failed, RFID Max Retry, Platen Open, Ribbon Stall, Stacker Fault, Stacker Full	
Printer Warning ¹	Events generated by the printer when warnings occur or are cleared.	Any Ribbon Low	

Table 9 Events And Parameters

Event Name	Description	Parameters	Security Key Required
Panel/ODV Events			
Panel Key	Event generated by the printer when the operator presses a key on the operator panel.	Key Combination	Security key is required when a key combination (more than one key) is selected.
	Event generated by the printer when the operator uses a key combination.	Key Combination	
ODV Status ¹	Event generated by the ODV (online data validator) of the printer.	Unscannable Code Check Media, Quality Error All Error Cleared	
Misc. Events			
PAA Event	Event generated by PAA.	Event identifier	
Data Field Changed	Event generated when a data field has changed.	Source, Condition, Value, Type	✓
Timer Expired ³	Event generated when a timer expires.	Timer Identifier	✓
Table Entered	Event generated when a table is entered or activated. This will be the first event generated when a table is activated with the exception of the power up event.	None	✓
Table Exited	Event generated when a table is exited, e.g. by selecting another table. It will be the last event generated before the table becomes inactive.	None	✓
UCP Data In	Event generated when the data received on the Universal Control Port (UCP) matches the data defined with the parameters of this event. Since this event requires that the UCP port be enabled, a warning dialog will display if this option is not enabled. This message will only be shown once for each GPF editing session.	Value	✓

Table 9 Events And Parameters

Event Name	Description	Parameters	Security Key Required
¹ Thermal only. ² Impact only. ³ If instances of this object type are not defined, a dialog box asks you to define some. If you click Cancel, the event will revert to the previous selected event.			

Event Descriptions

- **Input Opto-Coupler**

For external input signals you can specify the number of the opto-coupler to view and the level in which the event is seen as active. Click the opto-coupler symbol  to select the active state.

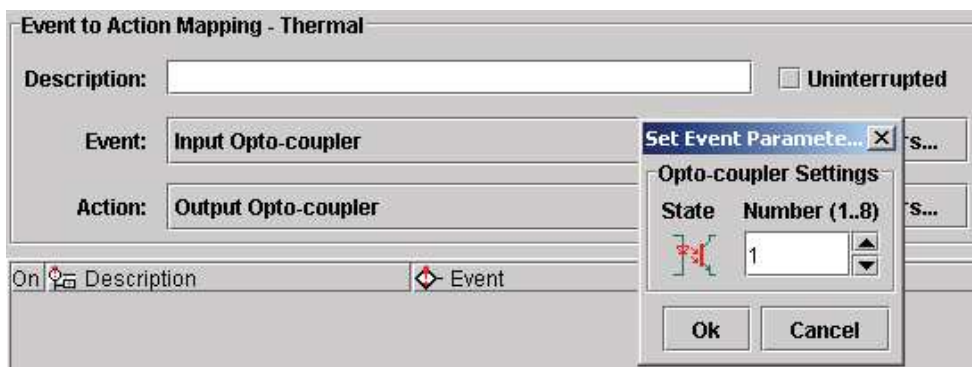

Figure 189 Setting the Opto-coupler Number and State

NOTE: With the advanced GPIO features enabled in the printer, it is possible to handle all eight opto-coupler input as a special Data Field (see Data Fields on page 211). This results in 248 different input combinations that can be used to trigger an action.

- **Printer Powered Up**

This event is delayed until the moment the printer reaches the Powered- up-online or Powered-up-offline state. The delay is required so the printer can finish its power-on reset cycle before any reaction to an event generates.

NOTE: With the advanced GPIO features enabled in the printer, GPIO will either start up using the printer configuration or a predefined configuration. Select **File ► GPIO Configuration** then select the Power-Up Settings, GPIO Control tab to set the power-up option.

- **Printer Online**

When the printer goes online by pressing the Pause key, the action related to this event is accepted.

- **Printer Offline**

When the printer goes offline by pressing the Pause key or the menu key, or if there is any other reason that causes the printer to switch offline, the action related to this event is accepted.

- **Printer Paused**
This event happens when the printer pauses because of the “pause printer” action. The printer accepts data from the host and parses this data until its buffers are full. No printing will take place. The print engine is offline but the printer’s data processing unit is still online.
- **Power Save Mode Entered**
This event signals the moment when the printer enters Power Save Mode.
- **Power Save Mode Exited**
This event signals when the printer becomes active again.
- **Start Data Processing**
This event signals the start of the processing of received data. This is not the same as the Start Printing event.
- **End Data Processing**
This event signals the end of the data processing cycle. This is not the same as the end printing event.
- **Printer Buffers Empty**
This event takes place as soon as the print buffers are emptied.
- **Single Label Printing, Enabled**
This event happens on the Enter Single Label Mode action. It indicates that this mode has been entered.
- **Single Label Printing Invoked**
This event indicates that the Single Label Mode is terminated and that normal, continuous printing is active.
- **Label Pending**
This event generates when the printer is in Local mode (i.e., the print engine is temporarily stopped) and all incoming data has been processed.
- **Started Printing**
This event happens when the printer starts printing. The printer starts printing when all data processing is done, there is actual data to print, and the printer is no longer in local mode. The event will not happen on “paper moves without print.”
- **Label Printing**
This event occurs when the label is printing.
- **Ended Printing**
This event indicates the end of actual printing. The paper may still be moving as printing does not always stop at top of form.
- **Started Paper Move**
This event indicates the beginning of the paper motion.
- **Label Printed**
This event occurs when a number of labels stored in the printer have finished printing. If the labels print as a single job without any wait time, the event will be a short pulse. If the printer is placed in local mode and the labels are printed using the *print next label* action, the event will happen once for each label.

- **Overstrike Pending**
The printer generates this event when a label overstrike is pending.
- **Label Completed**
The printer generates this event when a label is completed.
- **Label Rejected**
The printer generates this event when a label is rejected.
- **Label Canceled**
The printer generates this event when a label is canceled.
- **Label Failed**
The printer generates this event when a label fails to print.
- **Label Present**
In label peel off applications, this event happens when the label present sensor detects a label in position (ready for application). It may be used to signal the availability of a label to an applicator system.
- **Label Taken**
This event generates when the label is taken from its ready to apply position. It can be used to tell the host that a new label can be printed.
- **Labels Pending, None**
The printer generates this event when it has no more pending labels to print.
- **End Paper Move**
This event indicates the end of paper motion.
- **Cutter Cycled**
The printer generates this event when the cutter cycle is completed.
- **Sensor Event**
This event generates when the action to set the sensor to ignored on or off, either is executed or failed.
- **Printer Error/Printer Warning**
The printer generates this event when errors or warnings occur or are cleared. You can select the actual error or warning as the event.

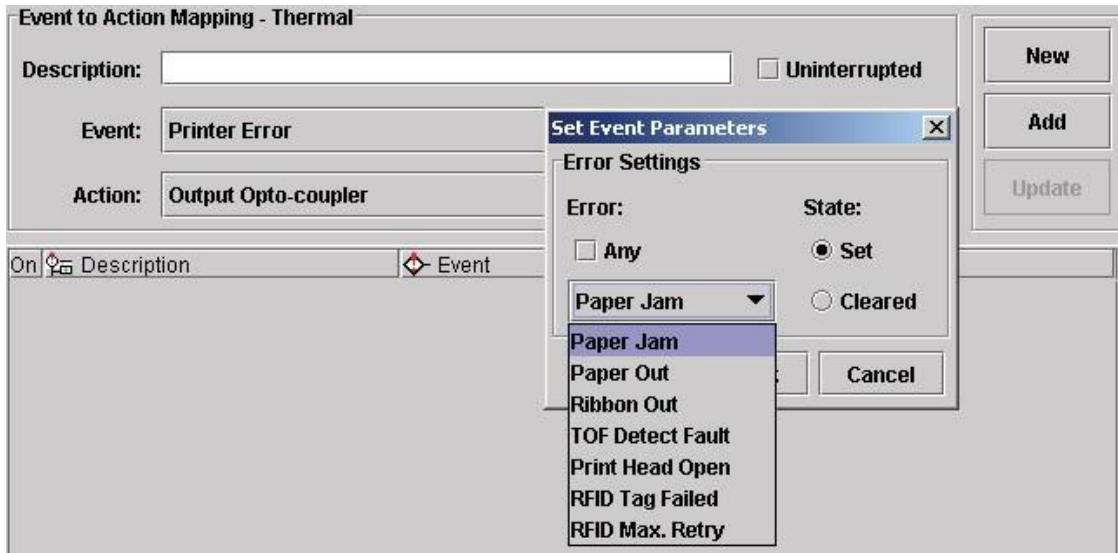

Figure 190 Setting Event Parameters

To select the Printer Error event, click the Event drop-down menu and select Printer Error as the event parameter. The Set Event Parameters dialog box opens. Click the Any box to uncheck the setting. A list of errors (or warnings) is now available for selection. From the Error drop-down menu, select the required parameter.

The Set state identifies the event when the problem happens. The Cleared state specifies the event when the problem is solved.

TOF Detect Fault happens if the T5000 does not find a Top of Form indicator (or a gap) within a specified amount of time after printing starts. It can be used to prevent the feeding of blank labels in print and apply applications.

- **Panel Key**

This is an event in which the operator panel keys are parameters. The event allows you to change the function of the keys or to disable selective keys. For example, if the panel key event Menu results in the action Consume (or do nothing) the menu key has been disabled.

NOTE: When the advanced GPIO features are enabled in the printer, this allows an event to be generated when multiple keys are pressed simultaneously. Many additional key combinations can be used to trigger an action.

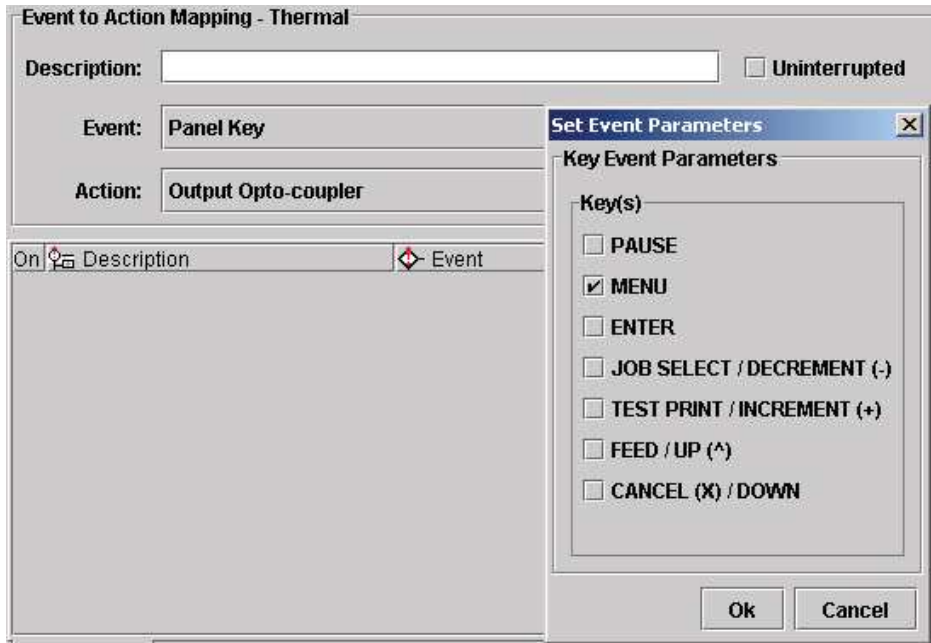

Figure 191 Setting Panel Key Event Parameters

- **ODV Status**

This selection allows you to react to output from the ODV (online data validator). The parameters allow you to program GPIO to act if there is no barcode, if there is any or a specific error in the barcode, or when all ODV errors have been cleared.



Figure 192 Setting ODV Parameters

- **PAA**

PAA generates an event on a user specified input string. A large number (32000 or more) of PAA events can be generated through the use of an identifier.

- **Data Field Changed**

This event happens if the value in a given data field changes. Certain conditions are applicable, see Data Fields on page 211.

- **Timer Expired**

This event happens when a user defined timer expires or when a user defined time is reached. See Timers on page 224.

- **Table Entered**

This event happens when a new mapping table is entered. The event can be used to execute actions regarding new tables. For example, when you want to check the content of a datafield and no other events are available.

- **Table Exited**

This event generates before going to a new table. This event can also be used to execute last minute actions. For instance, if we want to go from table 1 to either table 2 or 3 and if a variable needs to be initialized, we could use the table exited event. This way we only have to specify the initial value once.

- **UCP Data In**

This event generates when the data received on the Universal Control Port (UCP) matches the data defined with the parameters of this event. This event requires that the UCP port be enabled; a warning dialog will be shown if this option is not enabled. This message displays only once for each GPF editing session.

NOTE: The events Datafield Changed, Timer Expired, Table Entered, and Table Exited, and UPC Data In are only functional with the advanced GPIO features enabled in the printer.

Actions

The Action field allows you to specify which action should be linked (or mapped) to the selected event. Table 10 lists all possible actions and related parameters.

Table 10 Event Actions and Parameters

Action Name	Description	Parameters	Security Key Required
Output Opto-Coupler	Action that applies to the output Opto-Couplers.	State, Pulse, Repeated Pulse, Number (1..8), Pulse Duration (ms)	
Output Relay	Action that applies to the output relays.	Action, State, Pulse, Repeated Pulse, Number (1..4)	
Printer Status			
Printer Online	Action switches the printer to online mode.	None	
Printer Offline	Action switches the printer to offline mode.	None	
On/Offline Switch	Action toggles the printer between offline and online mode.	None	

Table 10 Event Actions and Parameters

Action Name	Description	Parameters	Security Key Required
Data Control			
Clear Buffer	Action clears all of the printer's internal buffers. Data stored in flash (e.g. form templates) are not cleared.	None	
Engine Control			
Pause Printing ¹	Action pauses printing after the current label is printed. Labels in the queue will stop printing until the start printing action is received.	None	
Resume Printing ¹	Action resumes printing if printing was stopped with the pause printing action.	None	
Print Next Label ¹	Action starts printing the next label in the queue if printing in single label printing mode.	None	
Reprint Next Page ²	Action starts printing the next page in the queue if printing in single page printing mode.	None	
Reprint Last Printed Label ¹	Action reprints the last printed label.	None	
Form Feed	Action performs a form feed.	None	
Move Paper	Action moves the paper a specified distance in a specified direction. Use a data field to specify distance.	Distance to TOF, Direction Forward/ Backward, U16 data field.	
Cut Once ¹	Action applies a paper cut after all pending labels if the cutter is installed.	None NOTE: The Cut Once action is not executed if Media Handling is not set to Continuous or Cut.	
Cut Immediate ¹	Action applies a paper cut in the current position if the cutter is installed.	None	

Table 10 Event Actions and Parameters

Action Name	Description	Parameters	Security Key Required
Flush Next Label ¹	Action deletes the next label in the print queue when in single label printing mode.	None	✓
Single Label Printing, Enable ¹	Action enables single label printing.	None	✓
Single Page Printing, Enable ²	Action enables single page printing.	None	✓
Single Label Printing, Disable ¹	Action disables single page printing.	None	✓
Single Page Printing, Disable ²	Action disables single page printing.	None	✓
RFID: Program Next Label ¹	Action puts the printer in continuous page printing mode.	None	✓
Sensor Action	Action turns the media sensor on or off.	Sensor, Action Ignore On/Off	✓
Power Save Action	Action turns power saving on or off and enters or exits power save mode.	On, Off, Enter, Exit	✓
Manual Overstrike	Action performs a manual overstrike.	None	✓
Panel Control			
Lock Panel	This action disables all the buttons on the operator panel.	None	
Unlock Panel	This action enables the buttons on the operator panel.	None	
Key Handling	This action is only enabled if the selected event is Panel Key.	Consume	✓
Beep	This action defines the number of times the buzzer beeps.	Beep Count	✓
Blink	This action changes the state of a printer's led or lamp.	State, LED/Lamp	✓
General			

Table 10 Event Actions and Parameters

Action Name	Description	Parameters	Security Key Required
Disable GPIO Events	This action prohibits the Event Parser from executing any actions except for the Enable Event Parser action. This allows an application to temporary disable the GPIO Event Parser.	None	
Enable GPIO Events	This action allows the Event Parser to start executing all actions again.	None	
Reply to Host	This action sends user defined data to the host.	Reply, Interface	
Wait	This action waits a specified time before the next action on the same event is performed. Use the data field to specify the time to wait. Only available if one of the numeric data fields is defined.	Time to Wait in milliseconds	
PAA Control: Reset CST	Time to wait in ms. This action will reset the active CST.	None	✓
Select Mapping Table	This action allows the user to select the active mapping table. This action is only enabled if there is more than one mapping table.	Name of Table to switch to.	
Data Field	Performs an action on a user-defined data field. If no data fields are defined, the user is asked to define data fields first.	Destination, Operator, Source, Type	✓
Send Report ³	This action allows the user to send a report to a destination. If no reports are defined, the user is asked to define reports first.	Source, Destination, Seconds	✓
Timers/RTC ³	Performs an action on a user-defined timer. If no timers are defined, the user is asked to define timers first.	Timer, Action	✓
<p>¹ Thermal only. ² Impact only. ³ If no instances of this object type are defined, the user is prompted to define the types now. If the user selects Cancel, the action will revert to the previous selected action.</p>			

Action Descriptions

- **Output Opto-Couplers**

The opto-coupler number to activate can be specified as well as the level (or state) required for this output. Select the state by clicking the opto-coupler symbol. If the Pulse parameter is selected, the pulse duration can be set in increments of 50 ms between 50 and 2,147,483,647 ms. This allows pulses up to 24.8 days in duration. If Repeated Pulse is selected, the pulse will repeat with a 50% duty cycle until deactivated.

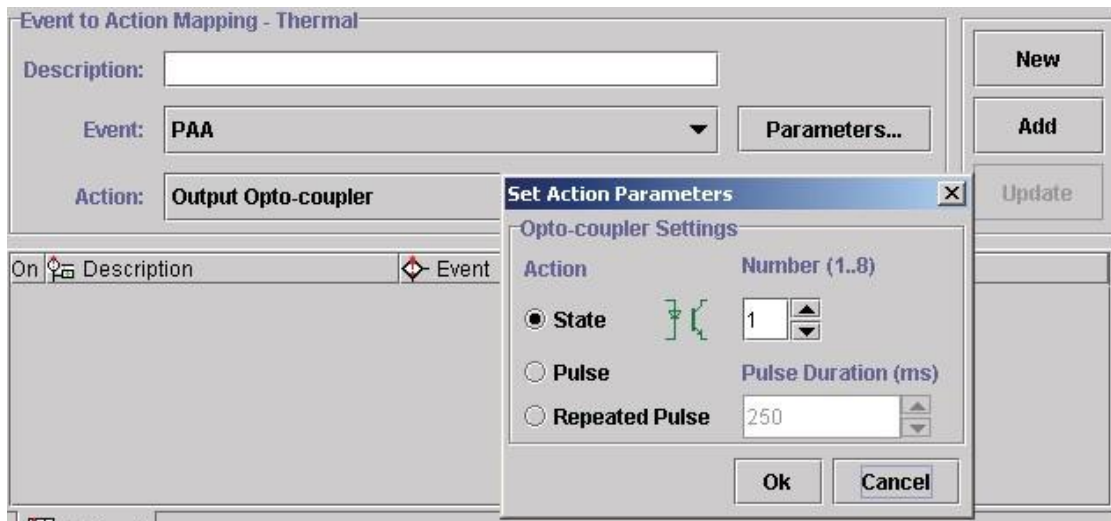

Figure 193 Setting Output Opto-coupler Action Parameters

- **Output Relay**

The relay number to activate can be specified as well as the level (or state) required for this output. You can select the state by clicking the relay symbol. Pulsed behavior for the relays is equivalent to the pulsed behavior of the opto-coupled outputs.

NOTE: The advanced GPIO features enabled in the printer allow handling all eight opto-coupler outputs as well as the relays through a Data Field. See Data Fields on page 211. This gives the single outputs a large number of output combinations that can be used to initialize external actions.

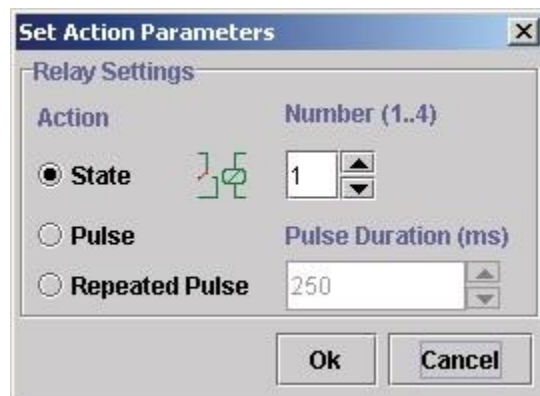

Figure 194 Output Relay Settings

- **Printer Offline/Printer Online**

These two actions switch the printer offline or online.

- **On/Offline Switch**

This action allows the printer to be switched offline if it is online, and to be switched online if it is offline. The switch works as a toggle.

- **Clear Buffer**

A host or application controlled memory clear.

- **Pause Printing**

This action results in the print engine going offline with the interface to the host still active. This allows receiving and pre-processing of host data until the buffer is full.

- **Resume Printing**

If there is data in the buffer, the printer resumes printing until it is switched offline or paused through the Pause Printing action.

- **Print Next Label**

This action can have different functions. If GPIO Print & Apply is enabled, the action is Print Next RFID Label. In Single Label Printing Mode, the action is Print Next Label. If the user switches the printer to Pause mode without going into Single Label Printing Mode, the Print Next Label also functions similar to the previous version of GPIO.

IMPORTANT Do not place the printer in Pause mode and select the Single Label Printing Mode, this stops the engine and prevents the printer from printing.

- **Reprint Last Printed Label**

This action reprints the last page printed.

- **Form Feed**

This action performs a form feed.

- **Move Paper**

This action allows the movement of paper either to the next top-of-form (the gap) or, if required for specific applicator functions, a specified distance forward or backward taken from either a fixed value or a U16 data field. See Figure 195.

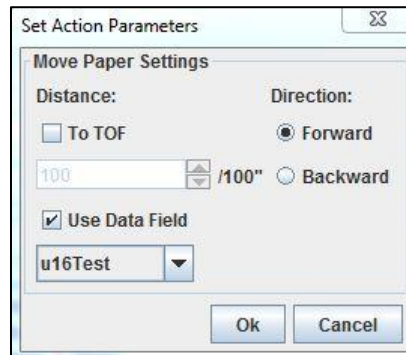

Figure 195 Setting Move Paper Action Parameters

- **Cut Once**
Cuts the media at TOF after all pending labels in the printer have been printed.
- **Cut Immediate**
Cuts the media in the current position.
- **Flush Next Label**
This action removes a single form (the one that is ready to be printed) from the queue in the printer. It can be used in Secure Printing configurations where two printers are interconnected through GPIO and one printer is ready to take over printing if the first printer develops a problem.
- **Single Label Printing, Enable**
This action prints one label at a time.
- **Single Label Printing, Disable**
This action disables single page printing.
- **RFID: Program Next Label**
This action is specifically designed for RFID Print and Apply applications where the programming of the RFID tag in the label does not have to occur simultaneously with the printing of the actual text on the label.
- **Sensor Action**
This action turns the media sensor on or off. See Figure 196.

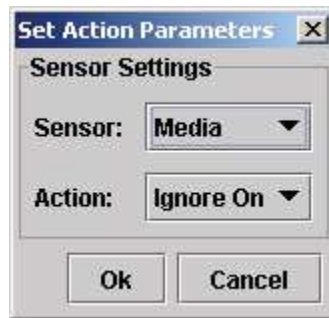

Figure 196 Setting Sensor Action Parameters

- **Lock Operator Panel / Unlock Operator Panel**
Once executed, the operator panel will be locked or unlocked. When locked, the operator panel can still be accessed through the virtual operator panel of PNE Auto ID. If the Disable Event Parser has been executed, the operator panel will be unlocked.
- **Key Handling**
This action allows the user to specify how the actual Key Event should be handled. Selecting *Consume* results in the original key function not being executed (it is consumed by GPIO).
- **Beep and Blink**
These actions allow the beeper to beep a specified number of times. The Online lamp on the printer switches on, off or blinks at the normal printer controlled rate.
- **Enable GPIO Events/Disable GPIO Events**

These actions allow you to switch on or off the event parsing of GPIO. When disabled, the only action GPIO will execute is the enable event parser action.

- **Reply to Host**

The Reply to Host action allows the user to specify a data stream that will transmit to the host when the selected event takes place and to select the interface that should be used for this data transmission. Data entry can be in ASCII or in hexadecimal. The entry mode can be selected with the arrow keys: up arrow for ASCII entry mode and down arrow for Hex entry mode. See Figure 197.



Figure 197 Setting Reply to Host Action Parameters

- **Wait**

The parameter for this action specifies the time in 1/1000 seconds that GPIO will wait until the next action executes.

- **PAA Control: CST Reset**

This action resets the Use Once flags of the currently active PAA CST.

- **Select Mapping Table**

This action allows you to select one out of 64 mapping tables on a given event. If only a single mapping table has been defined, this selection is not available. The mapping table is selected by its name or by selecting *previous*. Selecting *previous* allows you to quickly return to the table previously active. The nesting of returns is allowed.

- **Data Field**

This action allows you to modify the data field on a given event. Several logical or arithmetical functions can be applied to the data in the data field. See Data Fields on page 211.

- **Send Report**

This action transmits a report to either the host computer through a selected interface, internally to the active emulation, or to the printer operator panel LCD. For the LCD you can select the upper or lower display line and the time the message will be visible. See Reports on page 217.

- **Timer**

This action allows the start and stop of timers. This can either be for a single delay time or be based on the Real Time Clock (battery backed-up or CPU). See Timers on page 224.

NOTE: The actions Select Mapping Table, Data Field, Send Report, Beep and Blink, and Timer is only available with the advanced GPIO features enabled in the printer.

Event to Action Mapping Buttons

The mapping table control buttons are used as follows:

- **New.** Clears the Name field and sets the Event, Action, and related parameters to default.
- **Add.** Adds a new Event-to-Action mapping to the current GPIO program.
- **Update.** Re-enters an Event-to-Action mapping after editing.

Click the buttons to copy an entry from the mapping table to the entry/edit fields for subsequent modification. Click the Update button to update the entry in the mapping table with the new data.



Figure 198 Event to Action Mapping Entry Control Buttons

The Uninterrupted check box is used to allow GPIO to finish an action without being interrupted. For instance, if an event results in a timer action the timer may be required to expire completely before another action is performed. Events happening during this uninterrupted time will be queued and reacted upon once the uninterruptable action is complete.

NOTE: The queued events will be acted upon directly and in sequence. Any timing will be lost.

Multiple Actions

If required, GPIO can execute a number of actions on a single event. Multiple actions specified for a single event will be executed in the order they are entered in the mapping table.

Figure 199 shows a mapping table where the first action is to enable GPIO events by making the Input Opto-coupler event active. The second action is to disable GPIO events by making the Input Opto-coupler event inactive. The third action is to perform a form feed. Since the GPIO Configuration Manager performs mappings in sequence, this program will not produce a clean sheet because the Form Feed action follows the GPIO disable command. A form feed cannot happen when all GPIO events are disabled first.

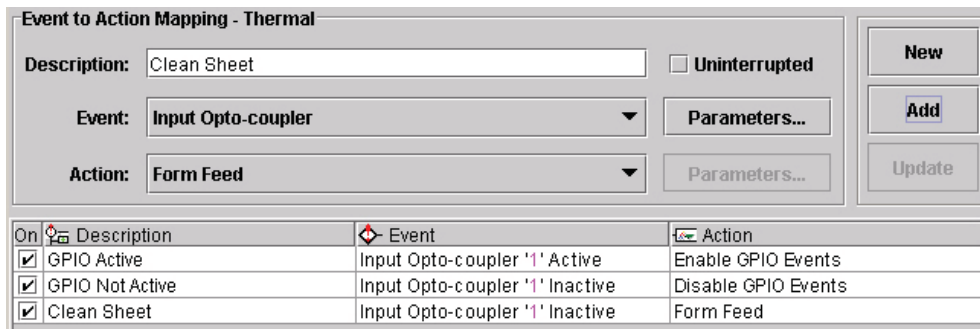

Figure 199 Incorrect Setup of Multiple Actions

Figure 200 shows a correct mapping table; a form feed is executed before the actual disabling of GPIO.

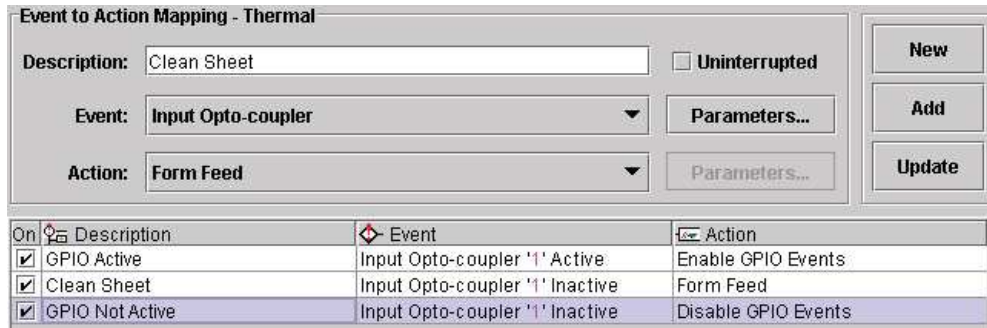

Figure 200 Correct Setup of Multiple Actions

To change the sequence in which the entries appear in the table, click and drag the entry to a different location in the table.

The ON Flag

You can use the On flag to temporarily disable entries in the GPIO mapping table. This is useful if an extensive mapping table is generated with many events leading to the same action. The On flag allows you to test each event reaction separately.

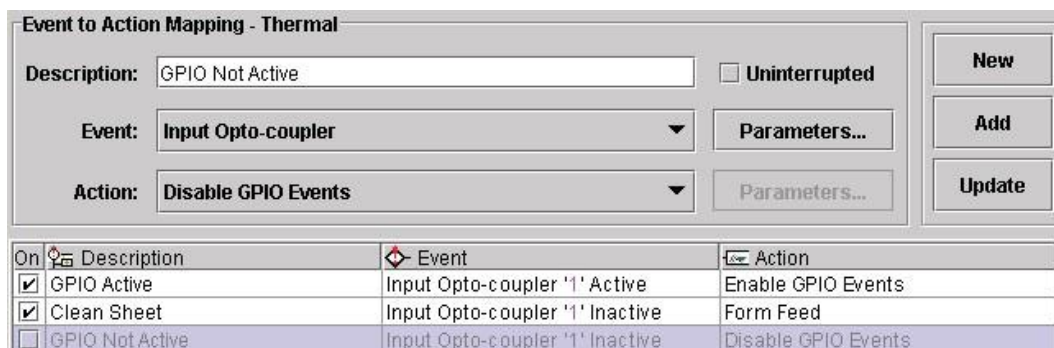

Figure 201 Using the On Flag to Enable or Disable an Action

The Status Line

The status line displays information related to GPIO. The tabs marked Table-1 and Table-2 allow selection of different event to action mappings. With the advanced GPIO features enabled, it is possible to select up to 64 tables. With the advanced GPIO features disabled, only a single table is available.



Figure 202 Viewing Status Line Information

The status line displays the date and time as well as the type of GPIO features used in the table. The 'A' indicates that at least one advanced GPIO feature is present. To run the mapping table in the printer the advanced GPIO features need to be enabled by the security key. Tables using only basic features do not require the security key to be loaded to the printer.

The series of zeros (or ones) are a reflection of the initial input and output states defined during the GPIO configuration. The first set of eight zeros represent the initial input opto-coupler state, the second set of

eight zeros represent the initial output opto-coupler state, and the last set of four zeros represent the relays.

The Sub check box needs to be checked if a GPIO mapping table is to be used as a subroutine. A table marked Sub will put the name of the table from which the selection is done on the stack. This name is used when the “select previous table” action is done to select the correct table to return to.

Data Fields

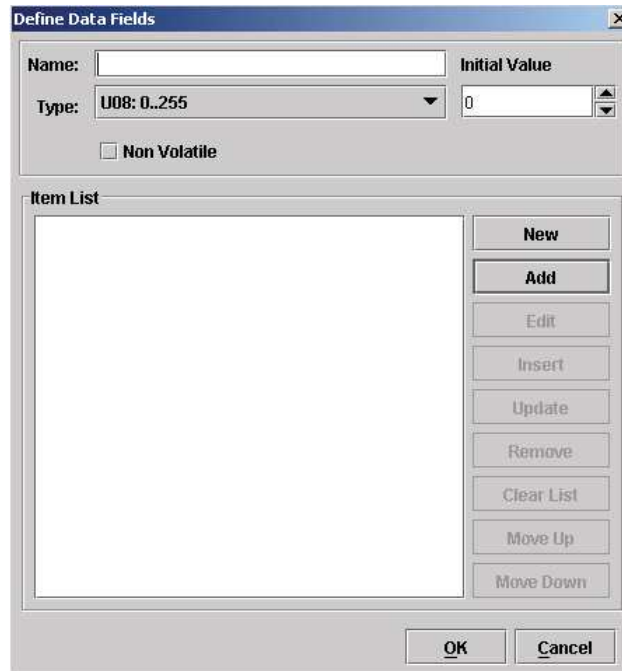

Figure 203 The Define Data Fields Dialog Box

Data fields are storage locations in the printer's resident memory. To define a data field, select **Edit** ► **Define Data Fields**. The Define Data Fields dialog box opens (Figure 203).

The Name field allows the user to create a data field descriptive to the user's needs. The Type drop down menu allows you to choose one of seven different types of data including 8, 16, or 32 bit signed or unsigned values and a string value. The Initial Value field allows you to set an initial value for the data type specified.

Checking the Non Volatile check box specifies that if a value in the data field has changed during the operation of the printer and the printer is powered down, the latest value of the data field will be the initial value when the printer is powered on. For example, if the data field contains a label count of 10,000 and that after printing 1,200 forms the printer is turned off due to error, with Non Volatile selected, the printer prints another 8,800 forms when the printer goes online again. If Non Volatile is not selected, the printer will print another 10,000 forms.

Data Field Actions

Data Field Actions are used to modify the content of the Data Field which results in an event.

An example is provided to better understand how Data Field Actions work in correlation to Data Field Events. For this example, we have a printer with a forms count defined in a data field in which after each form prints, the count is updated to reflect the correct number of forms still to be printed. Once the count reaches zero, we want a message to display in the second line of the operator panel. To do this, we need to define a Data Field and enter the total forms count (Figure 204).

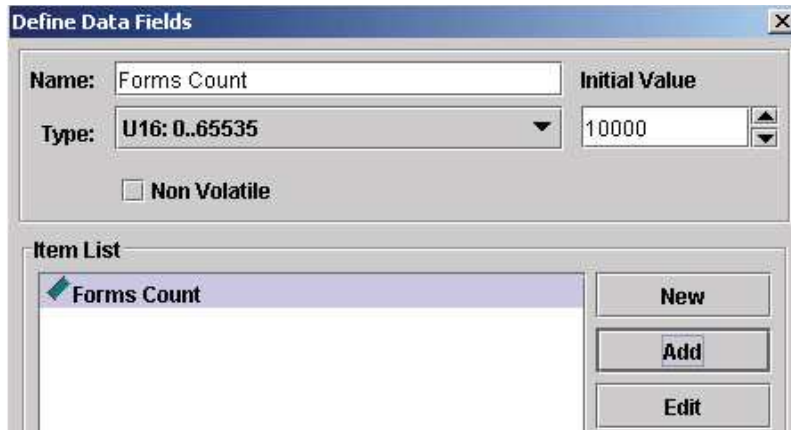

Figure 204 Defining Data Fields

1. Select Edit ► Define Data Fields.
2. Enter a descriptive name in the **Name** field.
3. Select the Data Field Type and enter the Initial Value.
 The data field type can be signed or unsigned bytes (-128...+127 and 0..255), signed and unsigned words (-32768...+32767), signed and unsigned long words (-2147483648...+ 2147483647), and ASCII strings.
4. Click **Add** to add the data field to the item list.

Once the data field is defined and added to the list, make sure that the count decrements by one each time a form prints. To set the parameters, use the Label Printed event and the Data Field action. In the Data Field parameter block specify what you want to happen when the event Label Printed occurs.

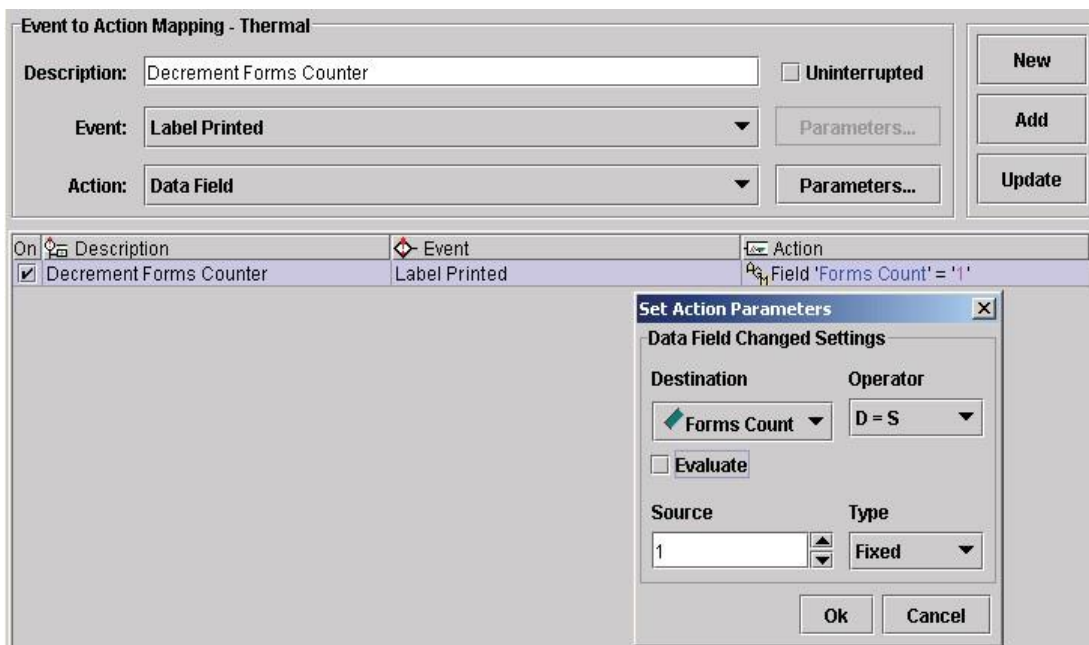

Figure 205 Setting Action Parameters

There may be an instance where you want to indicate an exact operation to perform on the Data Field. To decrement the label count by one each time a form prints, specify this event to happen in the Data Field parameter block when a label printing occurs. The value in the Source field will be used during the operation on the Data Field. To decrement the forms count by one for each label printed, set the Source value to 1. If more Data Fields are defined, one of those could be used as the Source value. To select the Source type, click the Type drop down menu and select Fixed or another defined data field. Operator Data Field Settings are defined in Table 11.

Table 11 Operator Data Field Setting

Operator	Results
$D = S$	Destination becomes Source
$D = D + S$	Destination 'plus' Source
$D = D - S$	Destination 'minus' Source
$D = D * S$	Destination 'times' Source
$D = D / S$	Destination 'divided by' Source
$D = D \% S$	Destination 'mod' Source
$D = D S$	Destination 'Logical OR' with Source
$D = D \& S$	Destination 'Logical AND' with Source
$D = D \wedge S$	Destination 'Logical EXOR' with Source
$D = D \&\sim S$	Destination 'Logical AND' with 'Inverted' Source
$D = \sim S$	Destination becomes 'Inverted' Source
$D = D \gg S$	Destination 'Logical Shift Right' Source times
$D = D \ll S$	Destination 'Logical Shift Left' Source times

First specify the data field itself, in this case a single (U16 Forms Count). If there are numerous data fields, select the one in which the action should apply. Next we need to set the operators to indicate the event we want to happen to this data field. The Source field sets the value in which we want the data field count to decrement by.

NOTE: When it is necessary to check/validate the value of a data field on a certain event, the user has to map a "Data Field" action to the event and check the "Evaluate" option. This will generate a "Data Field Changed" event similar to when the data field actually changes.

For this example, use $D = D - S$ (Figure 206) which results in the mapping table entry as seen in Figure 207.

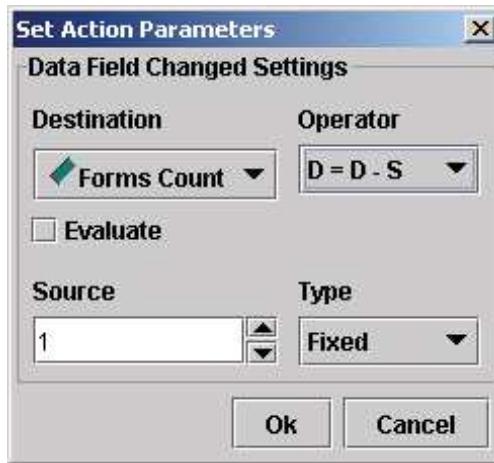

Figure 206 Setting Operator Parameters for a Data Field

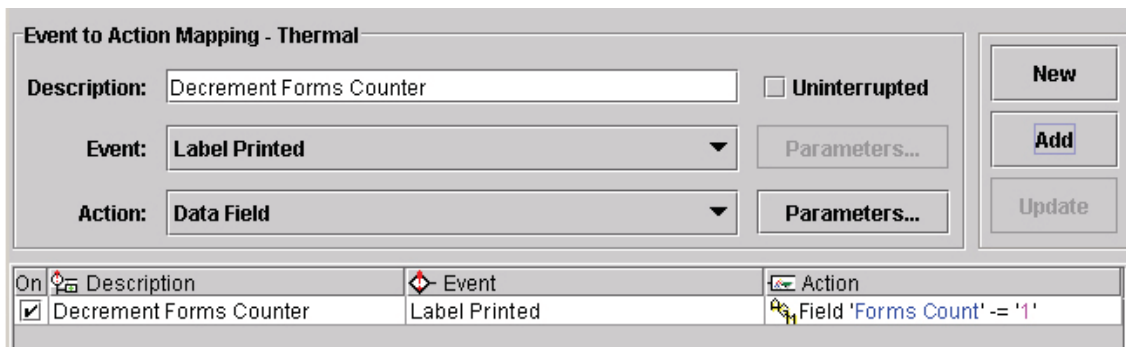

Figure 207 Generating a Mapping Table Entry

Now each time a label or form prints, the value in the data field forms count decrements by one. Next make sure that when the last form prints, a message is sent to the operator panel display as defined by setting a data field event.

Data Field Events

To have a message sent to the operator panel display indicating the number of forms still to be printed, you will need to keep track of the forms count. For this example create a new entry in the table named "Update LCD: Printing". Use Data Field Changed as the event. Each time the data field changes, a specific event generates.

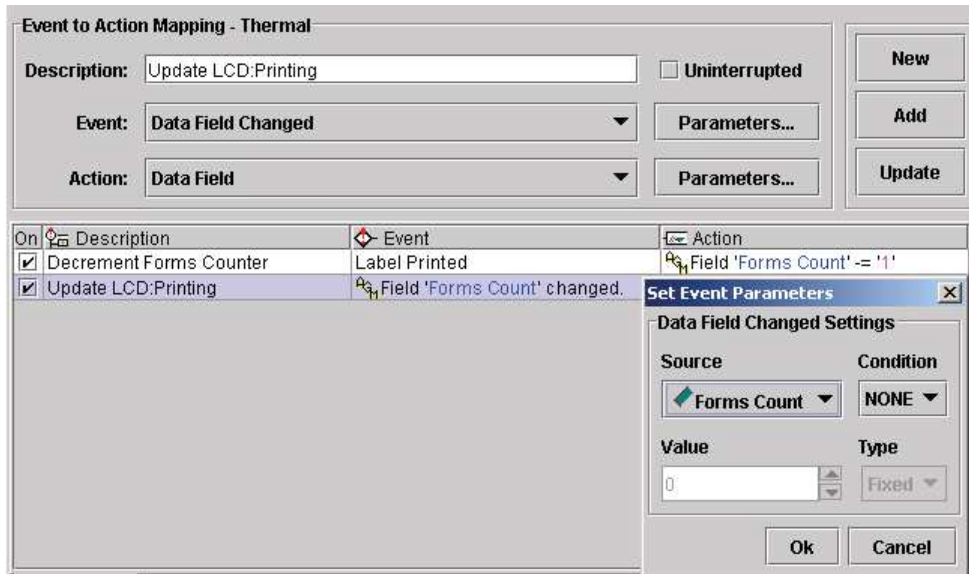

Figure 208 Creating a Event to Action Mapping Entry

1. Enter **Update LCD:Printing** in the Description field to create a new table entry.
2. Select **Data Field Changed** as the event. The Set Event Parameters dialog box opens.

The Source drop down menu is the data field for which the event is active. The Value field allows you to specify the number you want the Source to be compared. The Condition field indicates when exactly the related action takes place.

The following conditions are available:

Table 12 Conditions and Actions

Condition	
None	No condition, action taken on each change of Source (data field)
= =	'Equal' – action taken if Source equals Value
! =	'Unequal' – action taken if Source and Value are different
<	'Smaller Than' – action taken if Source is smaller than Value
< =	'Smaller Than or Equal To' – action taken if Source is smaller than or equal to Value
>	'Larger Than' – action taken if Source is larger than Value
> =	'Larger Than or Equal To' – action taken if Source is larger than or equal to Value

To set a forms counter, create two programmed entries,

Update LCD:Printing and **Update LCD:Done.**

- Update LCD:Printing

In the event that there is an unconditional change to the forms count, **Label Countdown** displays in the second line of the LCD.

- Update LCD:Done

In the event that the forms count reaches zero, the message **Label Printing Done** displays in the second line of the LCD.

- Ready Signal

In the event that the forms count reaches zero, the printer will beep five times.

NOTE: When it is necessary to check/validate the value of a data field on a certain event, the user has to map a “Data Field” action to the event and check the “Evaluate” option. This will generate a “Data Field Changed” event similar to when the data field actually changes.

The resulting mapping table in Figure 209 allows you to keep track of printed labels.

Event to Action Mapping - Thermal		
Description: Ready Signal		<input type="checkbox"/> Uninterrupted
Event:	Data Field Changed	Parameters...
Action:	Beep	Parameters...
On	Description	Event
<input checked="" type="checkbox"/>	Decrement Forms Counter	Label Printed
<input checked="" type="checkbox"/>	Update LCD:Printing	Field 'Forms Count' changed.
<input checked="" type="checkbox"/>	Update LCD:Done	Field 'Forms Count' changed and value == '0'
<input checked="" type="checkbox"/>	Ready Signal	Field 'Forms Count' changed and value == '0'
		Action
		Field 'Forms Count' -= '1'
		Send 'Label Countdown' to 'LCD Line 2', time is 'infinite'
		Send 'Label Printing Done' to 'LCD Line 2', time is 'infinite'
		Beep '5' times.

Figure 209 Creating a Forms Counter Entry

Reports

Reports are messages that can be sent to a number of destinations in the printer. A report is created by specifying one or more sections and by indicating the sequence in which these sections should be combined to form the report. Depending on the destination it may be required to indicate how long the report will be active.



Figure 210 The Define Reports Dialog Box

Defining Reports

Continuing with the previous example, we want to receive a message on the operator panel LCD that all forms have been printed.

To define a report do the following:

1. Select **Edit ► Define Reports**. The Define Reports dialog box opens with the Report tab active (Figure 210). Two tabs are available, the Report and Sections tabs.

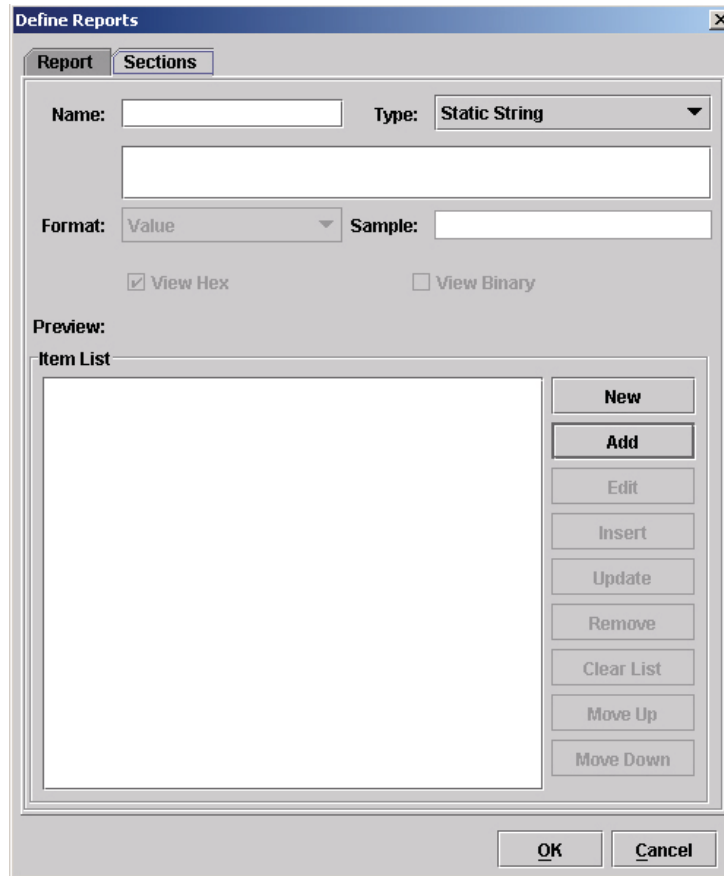

Figure 211 The Sections Tab of the Define Reports Dialog Box

2. Click the **Sections** tab (Figure 211). We will use this tab to define all sections needed to make the full report. The printer operator panel LCD has a maximum of 16 characters available per line to display the message.

Creating Sections

In continuing with the example, let us define the message as 'ALL DONE [xxxxx] where xxxxx represents the remaining count. This divides the report in four sections:

- **# OF LABELS** is the header section during printing
- **ALL DONE [** is the header used when all printing is done
- **xxxxx** is the forms counter data field content
- **]** ends the section.

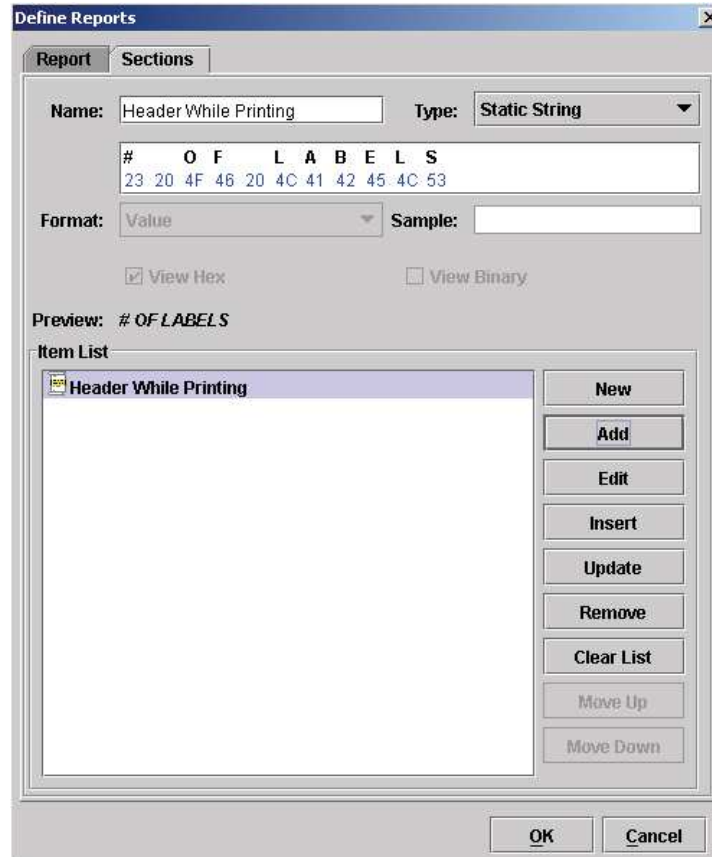

Figure 212 Defining a Sections Name

1. Type **Header While Printing** in the Name field.
2. Select **Static String** in the **Type** drop down menu.
3. Type **# OF LABELS** in the data pane.
4. Click **Add**. The Header section is added to the Item List pane (Figure 212).
5. Click the **New** button and type **Header When Done Printing** in the Name field to define a second section.
6. Select **Static String** in the **Type** drop down menu.
7. Type **ALL DONE [** in the data pane.
8. Click **Add**. The Header When Done Printing section is added to the Item List pane.
9. Click the **New** button and type **Forms Count** in the Name field to define a third section.
10. Select **Data Field** in the **Type** drop down menu.
11. Select **Value** as the Format.
12. Click **Add**. The Forms Count section is added to the Item List pane.

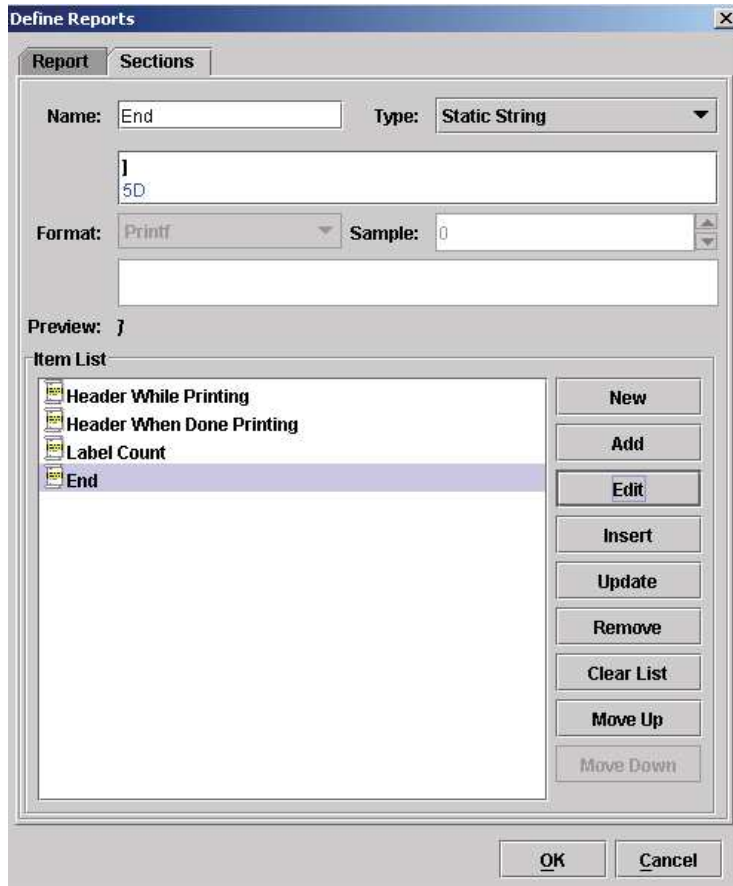

Figure 213 Creating a Sections Item List

13. Click the **New** button and type **End** in the Name field to define a fourth section.
14. Select **Static String** in the Type drop down menu.
15. Type **]** in the data pane.
16. Click **Add**. The End section is added to the Item List pane (Figure 213).

Creating Reports

We want to generate two reports using the sections just created. One report to generate during printing and the other to generate after printing is complete.

The first report, Label Count, is created with two sections: Header While Printing and Forms Count. This will give the following text on the LCD: # of Labels xxxx, where xxxx is the remaining label count.

The second report, Label Printing Done, is created with three sections: Header When Done Printing, Forms Count, and End. This will give the following text on the LCD: ALL DONE [xxxx] where xxxx is the remaining label count.

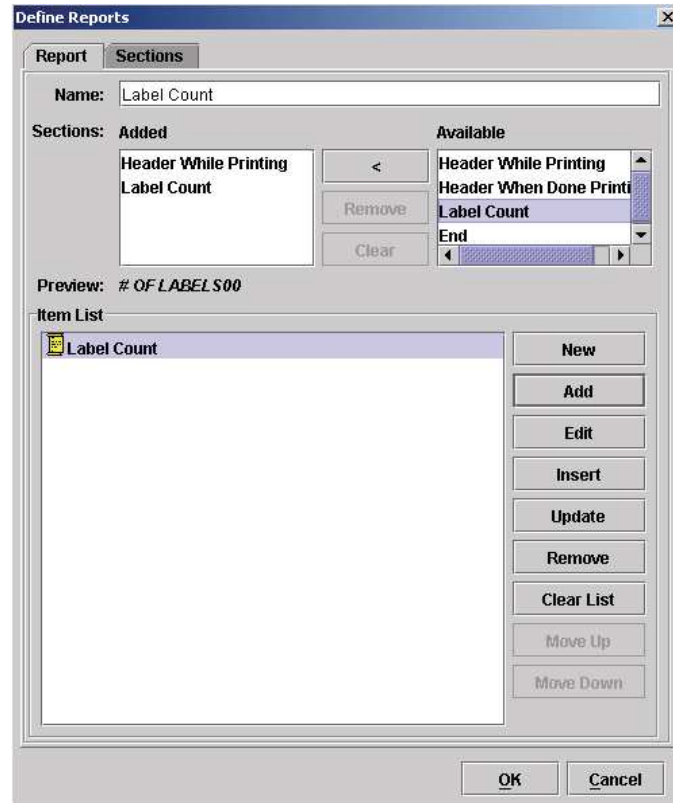

Figure 214 Adding Available Sections

1. Click the **Report** tab.
2. Type **Label Count** in the **Name** field.
3. Click the Header While Printing section under Available.
4. Click the < button to add the Header section.
5. Click the **Label** section under **Available**.
6. Click the < button to add the Label Count section.
7. Click the **Add** button. Label Count is added to the item list (Figure 214).

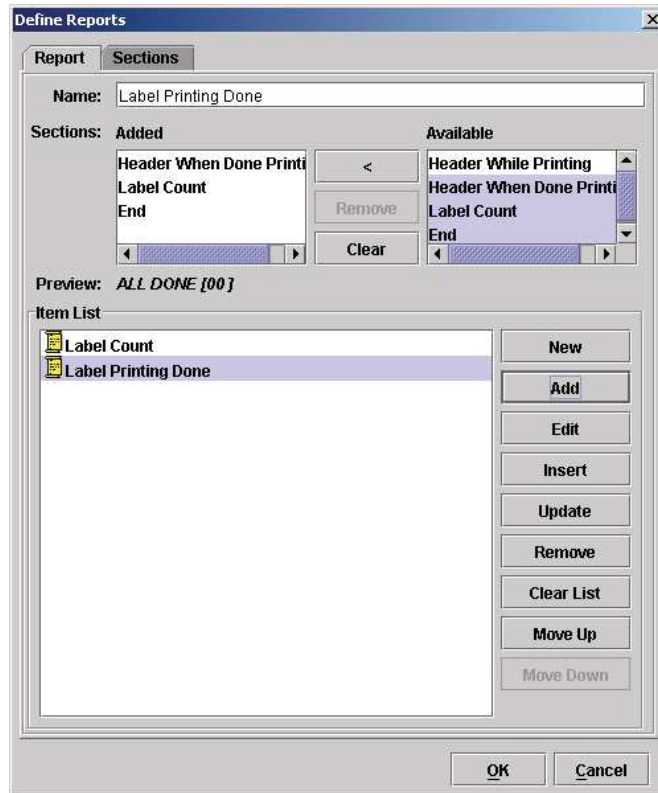

Figure 215 Adding Sections to a Report

8. Click the **New** button.
9. Type **Label Printing Done** in the Name field.
10. Click Header When Done Printing under Available.
11. Hold the **Control** key and click **Label Count** and **End** under Available.
12. Click the < button to add the Header When Done Printing, Label Count, and End sections.
13. Click the **Add** button. Label Printing Done is added to the item list. See Figure 215.
14. Click **OK** to close the dialog box.

Using Reports

To make sure the correct report is transmitted to the operator panel LCD, add the following entry to the mapping table.

The screenshot shows the 'Event to Action Mapping - Thermal' configuration window. At the top, there are fields for 'Description' (Forms Counter Tracking), 'Event' (Data Field Changed), and 'Action' (Send Report). There are also 'Parameters...' buttons for the Event and Action, and 'New', 'Add', and 'Update' buttons on the right. Below this is a table with three columns: 'On', 'Description', 'Event', and 'Action'. The table contains two entries: 'Decrement Forms Counter' with event 'Label Printed' and action 'Field 'Forms Counter' = '1'', and 'Forms Counter Tracking' with event 'Field 'Forms Counter' changed and value ==' and action 'Send 'Label Count' to 'LCD Line 2', time is '5''. A 'Set Action Parameters' dialog box is open over the second entry, showing 'Send Report Settings' with 'Source' set to 'Label Count', 'Destination' set to 'LCD Line 2', and 'Seconds' set to '5'. The dialog has 'Ok' and 'Cancel' buttons.

On	Description	Event	Action
<input checked="" type="checkbox"/>	Decrement Forms Counter	Label Printed	Field 'Forms Counter' = '1'
<input checked="" type="checkbox"/>	Forms Counter Tracking	Field 'Forms Counter' changed and value ==	Send 'Label Count' to 'LCD Line 2', time is '5'

Figure 216 Defining Entries in the GPIO Manager

Once the report has been defined and the Send Report action has been selected, the parameter block allows you to specify what is to be done with this report.

The Source drop down menu allows you to select a report previously created. The Destination options tell the system where to transmit the report. The Seconds field sets the time the report will be visible (applicable only to the operator panel LCD). See Figure 216.

Timers

The GPIO Manager allows timers to be used for different purposes. A timer can be programmed to create a delay between an event and an action or it can be programmed to generate an event at a specific time each day or even at a specific day and time each week.

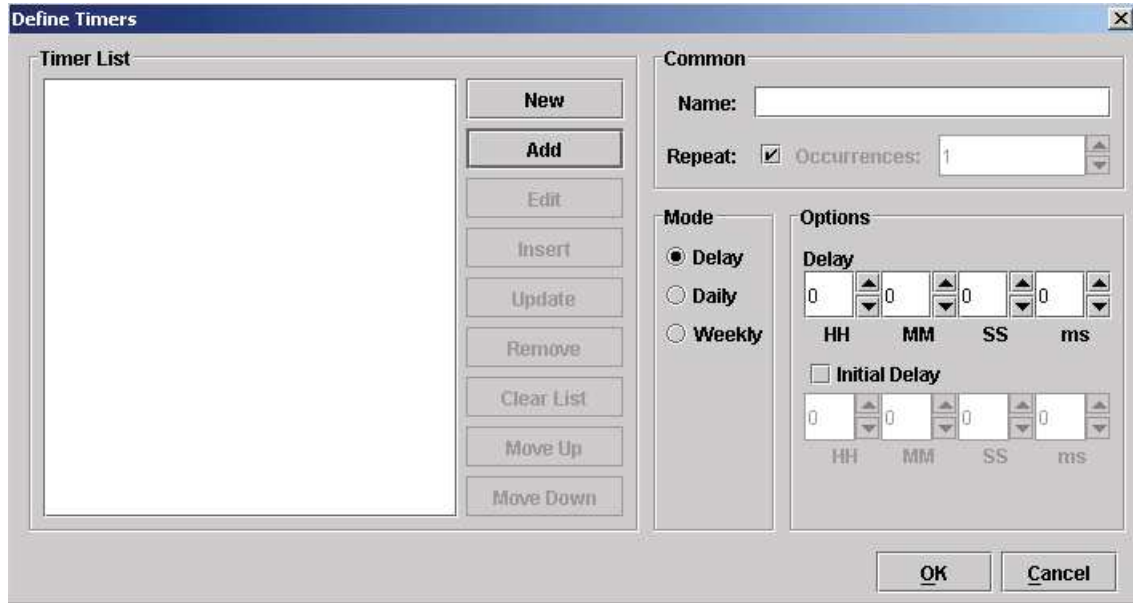

Figure 217 The Define Timers Dialog Box

Three modes are available: Delay, Daily, and Weekly which is discussed in the following sections.

Delay Timer Mode

NOTE: The Delay Mode and Initial Delay option can be controlled by a predefined data field. The data fields are named

<TIMER_NAME>_Delay and <TIMER_NAME>_InitialDelay, where
<TIMER_NAME> is the name you specified to the timer.

The Delay mode allows you to delay an action by a specified amount of time. For example, a printer is used on a production line and the operator is responsible for reloading ribbon when the printer runs out of ribbon. The operator normally requires approximately 1.5 minutes to replace the ribbon but if it takes more than 2 minutes we want the printer to prompt an action.

1. Select **Edit ► Define Timers**. The Define Timers dialog box opens with the Delay mode selected by default.
2. Type **Ribbon Reloading Error** in the Name field.
3. Check mark the Initial Delay check box to enable the initial delay parameters.
4. Enter **2** in the MM field under Initial Delay.

This specifies a two minute initial delay in which the operator has two minutes to reload ribbon. If the operator is able to change the ribbon and place the printer online within two minutes, the delay timer stops. If the operator is unable to change the ribbon within the two minutes, then the delay timer starts and the printer gives a warning. The delay timer will repeat for a specified amount of time until the error is cleared.

5. Enter **10** in the SS field under Delay.

If the operator is unable to change the ribbon within two minutes as specified in the previous step, then the delay timer starts in 10 seconds. In 10 seconds the printer will give a warning. The warning will repeat every 10 seconds until the error is cleared.

6. Click **Add**. The Ribbon Reloading Error delay timer is added to the Timer list. See Figure 218.
7. Click **OK**.

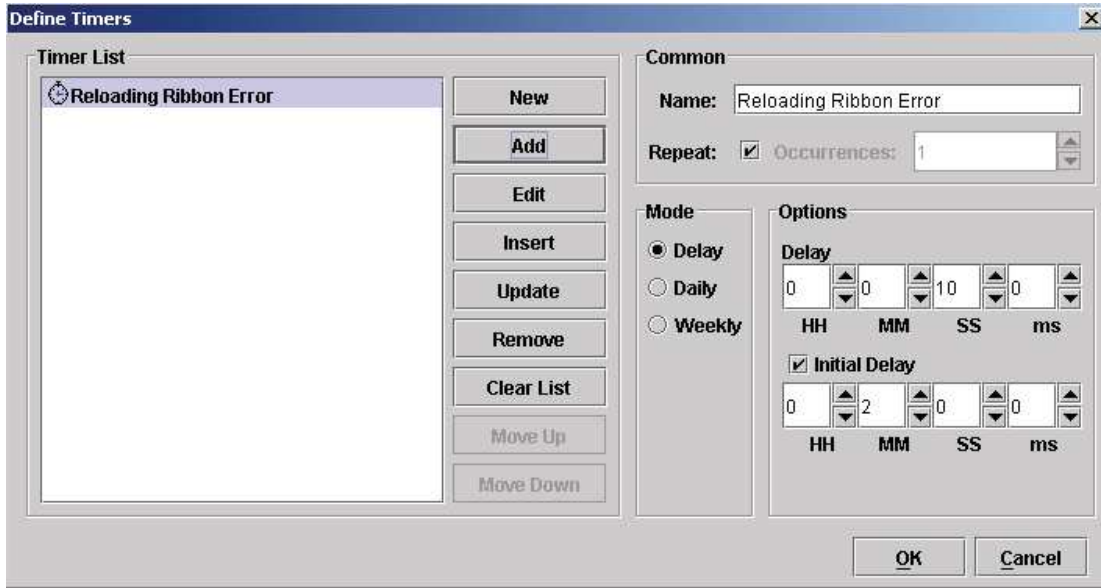

Figure 218 Setting a Delay Timer

Daily Timer Mode

To generate an event at a specific time each day, use the Daily timer mode. For example, you may want the printer to send a status report to the host system everyday at 12:45 p.m. The status report can include a number of datafields that keep track of paper, ribbon, or number of labels printed, etc. To program the timer to generate the status report, do the following.

1. Select Edit ► Define Timers.
2. Type **Daily Status** in the Name field.
3. Select **Daily** as the mode.
4. Enter **12** in the Hour field and **45** in the Minute field.
5. Make sure there is a check mark in the Repeat check box. This ensures that a status report will be sent everyday at 12:45 p.m.

If you want to specify a certain amount of days for the printer to send a status report, uncheck the Repeat box and enter a value in the Occurrences field. For instance, to have the printer send a status report for only five days, uncheck the Repeat box and enter **5** in the Occurrences field.

6. Click **Add**. The Daily Status timer is added to the Timer List. See Figure 219.
7. Click **OK**.

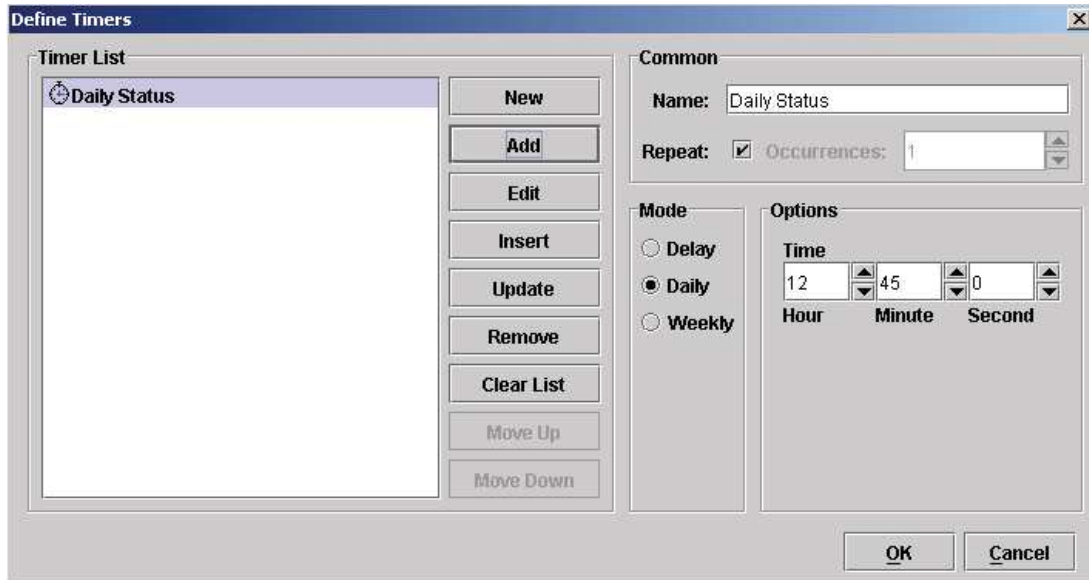

Figure 219 Setting a Daily Timer

Weekly Timer Mode

To generate an event on a specific time and day, use the Weekly timer mode. In continuing with the previous example, if you want the printer to generate a report to the host printer on certain days of the week at the same time, do the following.

1. Select **Edit** ► **Define Timers**.
2. Type **Weekly Status** in the Name field.
3. Select **Weekly** as the mode.
4. Enter **12** in the Hour field and **45** in the Minute field.
5. Check mark **Monday** and **Friday**. This specifies that an event will occur at 12:45 p.m. on Mondays and Fridays each week.

If you want to specify a certain amount of weeks for the printer to send a status report, uncheck the Repeat box and enter a value in the Occurrences field. For instance, to have the printer send a status report for only five weeks, uncheck the Repeat box and enter **5** in the Occurrences field. For this example, the printer sends a status report to the host printer on Mondays and Fridays at 12:45 p.m. for the next five weeks.

6. Click **Add**. The Weekly Status timer is added to the Timer List. See Figure 220.
7. Click **OK**.

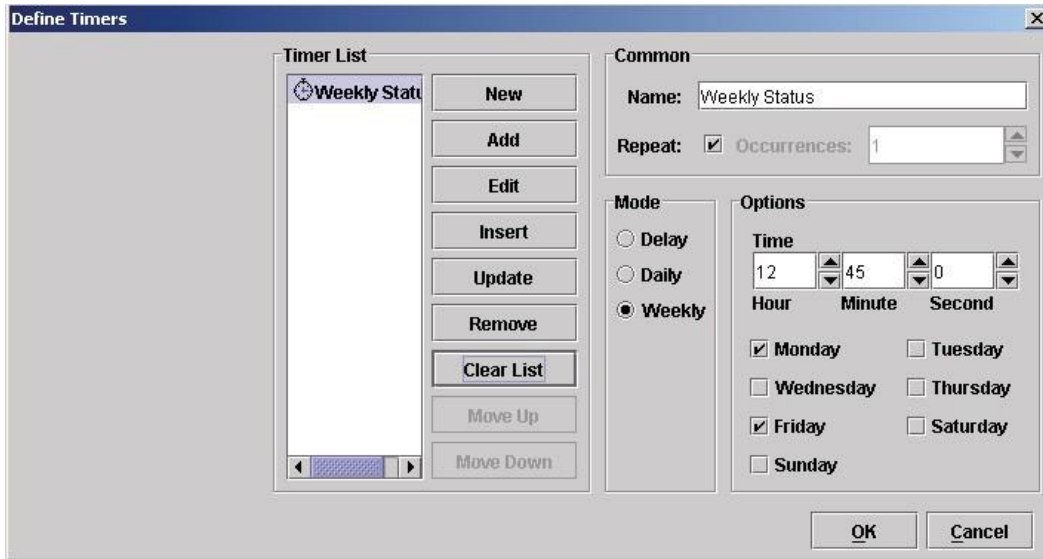

Figure 220 Setting a Weekly Timer

Using Timers

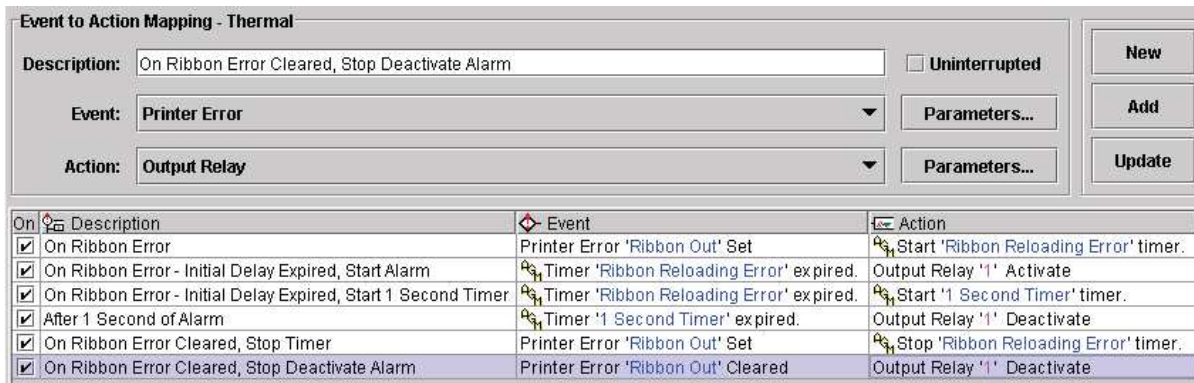

Figure 221 Using Timers to Activate an Alarm

When there is a ribbon error, the “On Ribbon Error” timer starts (Figure 226). First there is a two minute initial delay for the operator to change the ribbon. If the initial delay expires, it generates a timer expired event in which relay 1 activates. Relay 1 is set to sound an alarm. With a one second delay we make sure the relay is activated for only a short time. After 10 seconds, if the ribbon error is still there, the alarm sounds again. This will continue until the ribbon error is cleared at which time we will stop the “On Ribbon Error” timer and will deactivate relay 1.

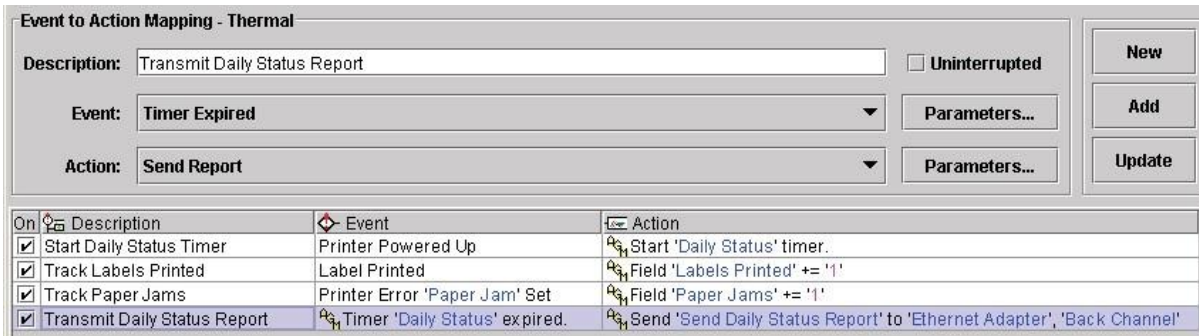

Figure 222 Using Daily Timers

To set a daily status timer, we define two data fields:

- Labels Printed – keeps track of the number of labels printed by incrementing the data field for each label printed.
- Paper Jams – keeps track of the number of paper jams by incrementing the data field for each paper jam.

Daily at 12:45 we want to transmit the number of printed labels and paper jams to the host. The format for this information should be

“Labels printed: {number};Ribbons used: {number}[CR][LF]”. Based on a number of sections, we create a report called Daily Status Report. See Figure 222.

Once defined, the timer needs to start at power-up. GPIO uses its own timer based on the Real Time Clock. During the day, the data fields are updated for each label printed and each paper jam occurrence. As soon as the timer expires, the daily status report transmits to the printer.

For a weekly status report, set the timer setting to transmit the report weekly.

Mapping

Download Mapping Tables

Once the mapping table has been designed and tested using the GPIO textbox it must be downloaded to the printer. This can be done in three ways:

Method 1: Using Normal Download Mode

1. Save the mapping table from within the GPIO manager using the default file name extension. This creates a downloadable file.
2. Set the printer in download mode (power-on with Menu and Down key pressed)
3. Send the file to the printer in a DOS box (also called Command Prompt); type **copy/b filename.ext lpt1**.

Method 2: Using PNE Auto ID

1. Save the mapping table from within the GPIO Manager using the default file name extension. This creates a downloadable file.
2. Attach the saved file as a download file to a printer and use the upgrade utility.

Once downloaded, the printer resident GPIO event parser detects the file and enables GPIO.

Method 3: Using the GPIO Download Facility

1. Click the Download  button on the GPIO toolbar.
2. Enter the required passwords for the GPIO program file and/or the communication sessions.
3. In the connection tab, specify the access method and configure the network or serial modem (if applicable).
4. Click OK to download the active mapping table(s) to the printer.

Once the mapping table is downloaded, the printer resident GPIO event parser will detect the file and enable GPIO.

Preloaded Table

If a GPIO board is installed in the printer but no user defined mapping table has been loaded, the printer will revert to a preloaded table.

Simple printer menus allow for programming three of the 11 (seven outputs, four inputs) pre-defined interface signals to a particular polarity or logic function that meets all typical print and apply requirements. They can also be compatible with all the features available on other manufacturers' external I/O interfaces. This allows easy migration of Printronix Auto ID T5000e or T5000r printers to new or existing systems. Field interface is accomplished through an industry standard 50-pin D type connector.

Input	Function	Notes
1	Reprint	Requires 16 Mbyte Printer Memory Option
2	Start Print	Polarity programmable via printer menu
3	Feed	
4	Pause	
5..8	Not Used	

Output	Function	Notes
1	Ribbon Low	
2	Ribbon Out	
3	Media Out	
4	Error/Service Required	
5	End Print	8 modes selectable via printer menu
6	Data Ready/On Line	Selectable via printer menu
7	Not Used	
8	Power On	

Mapping Examples

Indicator Lights Example

Imagine a factory floor with a number of printers. Over each printer are mounted lights that are controlled by the GPIO interface. The lights indicate the printer's status with the following conditions:

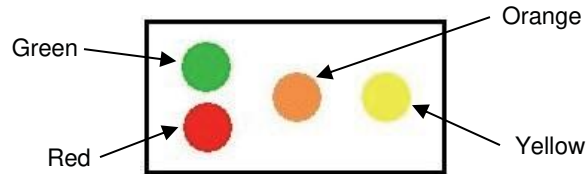

Light	Conditions
Green	Printer online, waiting for a print job or is currently printing, no warnings
Green and Orange	Ribbon low warning, printing continues
Green and Yellow	Label waiting for operator remove, printing stopped
Red	Printer offline, no errors
Red and Orange	Printer offline, ribbon out
Red and Yellow	Printer offline, paper out

The following table shows all input required for printer control, hardware interface, and connection.

On	Description	Event	Action
<input checked="" type="checkbox"/>	Testing	Input Opto-coupler '1' Active	Output Opto-coupler '1' Activate
<input checked="" type="checkbox"/>	On Ribbon Low	Printer Warning - 'Ribbon Low Set'	Output Relay '2' Activate
<input checked="" type="checkbox"/>	Slow Operator	Label Present	Output Relay '3' Activate
<input checked="" type="checkbox"/>	Responsive Operator	Label Taken	Output Relay '3' Deactivate
<input checked="" type="checkbox"/>	Printer Not Available	Printer Offline	Output Relay '1' Deactivate
<input checked="" type="checkbox"/>	Out of Ribbon	Printer Error 'Ribbon Out' Set	Output Relay '2' Activate
<input checked="" type="checkbox"/>	Out of Media	Printer Error 'Paper Out' Set	Output Relay '3' Activate
<input checked="" type="checkbox"/>	Printer Status Clear	Printer Online	Output Relay '1' Activate
<input checked="" type="checkbox"/>	Media Loaded	Printer Error 'Paper Out' Cleared	Output Relay '2' Deactivate
<input checked="" type="checkbox"/>	Ribbon Loaded	Printer Error 'Ribbon Out' Cleared	Output Relay '3' Deactivate

Figure 223 Setting Events and Actions for Printer Control

The connections made on the printer's I/O connector are displayed in the diagram below.

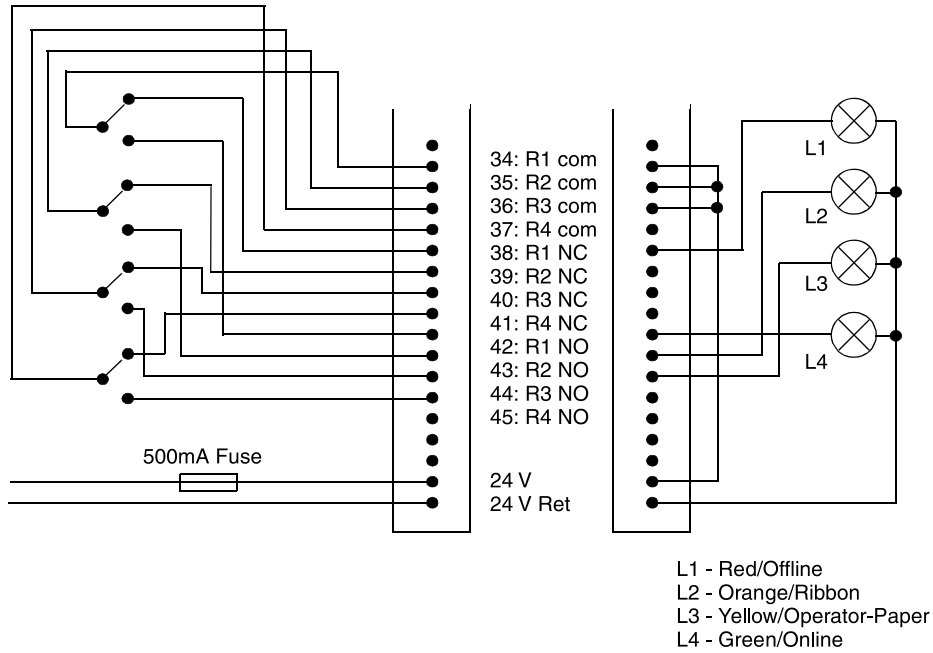

Figure 224 I/O Connections

Applicator Example

Imagine that a printer is connected to an applicator. When the printer has a label ready for the applicator to handle, it signals this event by activating one of the outputs. As soon as the applicator takes the label, the signal to the applicator will be removed until the next label is present. This way a simple interface connection between an applicator and printer is established. If any printer error occurs, relay 1 will activate and result in additional action. Once the problem is solved, placing the printer online clears the error report and printing can start again.

Event to Action Mapping - Thermal

Description: Uninterrupted

Event: Parameters...

Action: Parameters...

On	Description	Event	Action
<input checked="" type="checkbox"/>	Printer Status - Clear	Printer Online	Output Opto-coupler '1' Deactivate
<input checked="" type="checkbox"/>	Printer Status - Clear	Printer Online	Output Relay '1' Deactivate
<input checked="" type="checkbox"/>	Label Ready to Apply	Label Present	Output Opto-coupler '1' Activate
<input checked="" type="checkbox"/>	Label Taken by Applicator	Label Taken	Output Opto-coupler '1' Deactivate
<input checked="" type="checkbox"/>	General Printer Error	Printer Error 'Any' Set	Output Relay '1' Activate

Figure 225 Setting Events and Actions for Print and Apply

Protected Printer Example

To protect the printer's configuration from being overwritten, disable the operator panel buttons that are not used daily. The Online and Feed buttons should remain active while the rest disabled. The mapping table listed in Figure 226 shows this function.

If the GPIO board is installed in the printer these functions may be rendered inactive by deactivating the event parser using a special connector. If the connector is installed, the event parser is disabled and the panel functions as a panel on a printer. This allows service engineers access to all printer configurations. Once the connector is removed the panel remains protected.

Event to Action Mapping - Thermal

Description: Uninterrupted

Event: Parameters...

Action: Parameters...

New
Add
Update

On	Description	Event	Action
<input checked="" type="checkbox"/>	Disable Menu Key	Key 'MENU' pressed.	Key Handling , Consume = 'true'
<input checked="" type="checkbox"/>	Disable Enter Key	Key 'ENTER' pressed.	Key Handling , Consume = 'true'
<input checked="" type="checkbox"/>	Disable Job Select Key	Key 'JOB SELECT / DECREMENT (-)' pressed.	Key Handling , Consume = 'true'
<input checked="" type="checkbox"/>	Disable Test Print Key	Key 'TEST PRINT / INCREMENT (+)' pressed.	Key Handling , Consume = 'true'
<input checked="" type="checkbox"/>	Disable Cancel Key	Key 'CANCEL (X) / DOWN' pressed.	Key Handling , Consume = 'true'
<input checked="" type="checkbox"/>	Limited Front Panel Functions	Input Opto-coupler '1' Inactive	Enable GPIO Events
<input checked="" type="checkbox"/>	Normal Front Panel Functions	Input Opto-coupler '1' Active	Disable GPIO Events

Figure 226 Setting Events and Actions to Disable Front Panel Keys

If the two last entries in the mapping are entered, the following connector wiring results in a tool that can be used to enable or disable the normal front panel functions.

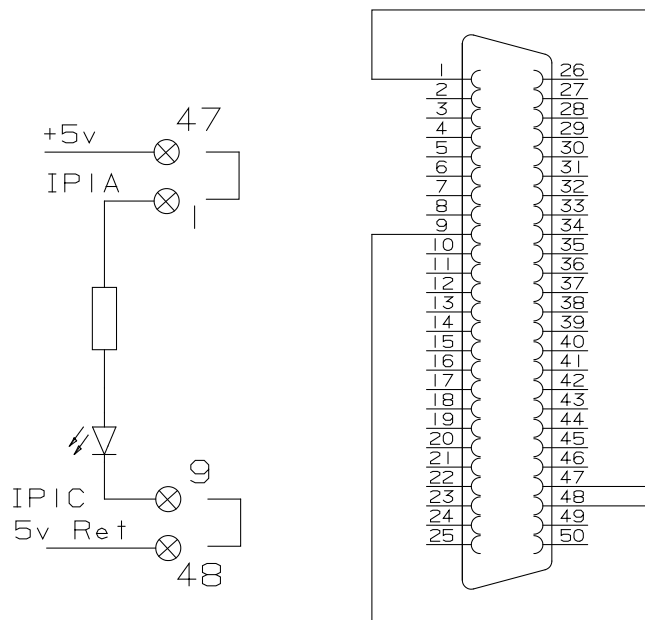

Figure 227 Connector Wiring for Protected Printers

Panel Selected Label Printing

Imagine that the requirement is to print one of three labels without host intervention. To do this, the operator needs to have a selection mechanism at the printer.

For this application, store the three labels (PGL files) in the printer. The three labels named label_1, label_2, and label_3 sit in the printer waiting for the ~EXECUTE command.

The mapping table in Figure 228 disables the Menu and Enter keys, reassigns the Feed function to the Down key, and the – key as the original Feed key. The + key sends the following data streams to the host via the serial port:

- the – key sends ~EXECUTE;Label_1;1<T><T>~NORMAL<T>
- the Feed key sends ~EXECUTE;Label_2;1<T><T>~NORMAL<T>
- the + key sends ~EXECUTE;Label_3;1<T><T>~NORMAL<T>

For more information, refer to the *PGL Programmer's Reference Manual*.

The mapping also creates the possibility of changing this modified printer into a normal one by plugging in the special connector from the Protected Printer example on page 232.

On	Description	Event	Action
<input checked="" type="checkbox"/>	Label 1 Selection	Key 'JOB SELECT / DECREMENT (-)' pressed.	Reply '~EXECUTE;LABEL_1;1<CR><LF><CR><LF>' to 'Serial'
<input checked="" type="checkbox"/>	Label 2 Selection	Key 'JOB SELECT / DECREMENT (-)' pressed.	Reply '~EXECUTE;LABEL_2;1<CR><LF><CR><LF>' to 'Serial'
<input checked="" type="checkbox"/>	Label 3 Selection	Key 'JOB SELECT / DECREMENT (-)' pressed.	Reply '~EXECUTE;LABEL_3;1<CR><LF><CR><LF>' to 'Serial'
<input checked="" type="checkbox"/>	Disable Menu Key	Key 'MENU' pressed.	Key Handling , Consume = 'true'
<input checked="" type="checkbox"/>	New Feed Key	Key 'CANCEL (X) / DOWN' pressed.	Form Feed
<input checked="" type="checkbox"/>	Normal Panel	Input Opto-coupler '1' Active	Disable GPIO Events
<input checked="" type="checkbox"/>	Special Panel	Input Opto-coupler '1' Inactive	Enable GPIO Events

Figure 228 Panel Selected Label Printing Mapping Table

When port switching is enabled, the serial port is the only port with which the printer can communicate to itself. To make the printer communicate to itself a special serial connector is required that connects the transmit data output to the receive data input. When one of the three operator panel buttons is pressed, the printer receives a message through the serial port sent out of that serial port by the same printer.

The serial connector in 25 pin and 9 pin is displayed in Figure 229.

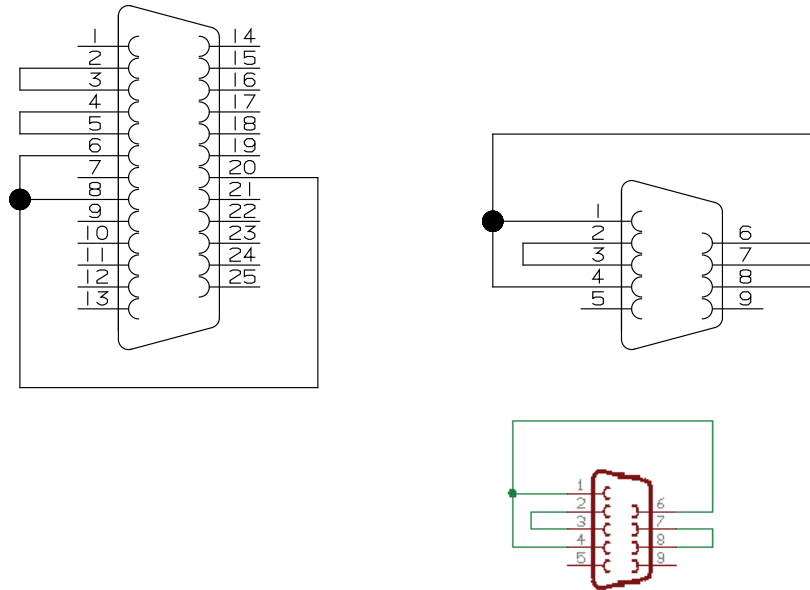

Figure 229 25 Pin and 9 Pin Serial Connectors

Once the PGL files and GPIO mapping table have been downloaded, and the special serial connector is installed on the printer, the printer will print label_1 when the – key is pressed, label_2 when the Feed key is pressed, and label_3 when the + key is pressed. The printer performs a form feed when the Down key is pressed. The Menu and Enter keys are non-functional.

Operator Panel with GPIO Disabled



Operator Panel with GPIO Enabled



Figure 230 Operator Panels with GPIO Disabled and Enabled

This works without the GPIO board installed in the printer; all it requires is the specially wired connector at the serial port. As indicated, it could also be combined with the Protected Printer example (see page 232).

A connector placed at the GPIO port could disable all this and allow a service engineer to work on the printer without restrictions.

Pin Code Protected Printer

The printer configuration protection described in the example on page 232 requires a special connector to disable GPIO so a service or application engineer can work on the printer without restrictions. The special connector requires one of the inputs to be specifically saved for protection purposes. You can use software to protect the printer using a PIN code that can be entered through the operator panel.

Imagine that the panel is partly disabled and the Online key, the Feed key and the Menu key are the only keys active. The Pause and Feed keys are operational because they are required for daily printer operation. The Menu key does not allow the user to open the configuration menu, instead it will ask for a PIN code before allowing the user to change the configuration.

For this application the operator panel keys get a value between 1 through 7 assigned to them using a datafield. A three digit PIN code allows any value between 111 through 777 to be used. For example, the assignment list include:

Panel Key	Number Assigned
Pause	1
Minus	2
Feed	3
Plus	4
Menu	5
Down	6
Enter	7

We'll use three more data fields named `new_pin`, `pin_number` and `pin_entry_count`. The `pin_number` data field contains the actual PIN number required to enable the configuration. The final result of entering code will be compared with this data field. If the codes and data fields match, the configuration will be enabled. If they do not match, the user is allowed two more chances. After that a message is sent to the host and the printer locks up. Use the `new_pin` data field to create the PIN number.

On each entry we'll send a message to line 2 of the LCD. For this example we'll use three messages with the following content:

- message one_pin contains '*--'
- message two_pin contains '**_'
- message three is either 'PIN accepted' or 'PIN incorrect'

When a key is pressed, the value of the corresponding data field is added to the value in `new_pin` (which initially contains 0). If the down key is pressed, `new_pin` now contains 6. If this is not the last (third) entry, the content of `new_pin` is multiplied by 10 (effectively shifting it over 1 decimal place). The message one_pin is sent to the LCD that now shows 'PIN number: *--'.

If the Feed key is pressed next, the value in the related data field (3) is added to `new_pin` which now contains 63. Again, it is not the last entry so `new_pin` is multiplied by 10, the content changes to 630 and the message two_pin is sent to the LCD to show 'PIN number: **_'.

If the Menu key is the third and last key pressed, the value 5 is added to new_pin. The content is now 635. Since this is the last key the number will not be multiplied by 10. Instead, we will send a message to the LCD. We now have the complete PIN code entered, compare it with the PIN code stored in the printer. This is done by a simple comparison of two data fields, new_pin and pin_number.

If the values match we'll make all keys available to the user. If the values don't match we'll increase the 'pin_entry_count' by one and start over. If the 'pin_entry_count' reaches three some message will be transmitted to the host and the complete panel will be blocked.

Data Fields, Reports, and Timers

The following (U16) data fields need to be created for this application where the content of the pin_number data field can be any value between 111 and 777.

Data Field Name	Initial Value
Pause_Key	1
Minus_Key	2
Up-Key	3
Plus_Key	4
Menu_Key	5
Down_Key	6
Enter_Key	7
Pin_Entry_Count	0
New_Pin	0
Pin_Number	635

Next to the data fields are status reports and information sent to the host if there is an error. The six reports listed in Table 13 need to be generated. Each report only has a single section that may have the same name as the report.

Table 13 Report Names, Sections, and Content

Report Name	Section Name	Content
pin_empty	pin_empty	PINumber:---
one_pin	pin_1	PINumber:*--
two_pin	pin_2	PInumber:**-
pin_accepted	pin_ok	PIN accepted
incorrect_pin	pin_error	PIN incorrect
locked	locked	*Printer Locked*

The PIN number application is described by reviewing each of the mapping tables and explaining each entry in that table.

Tables

On	Description	Event	Action
<input checked="" type="checkbox"/>	Disable Enter Key	Key 'ENTER' pressed.	Key Handling , Consume = 'true'
<input checked="" type="checkbox"/>	Disable Cancel Key	Key 'CANCEL (X) / DOWN' pressed.	Key Handling , Consume = 'true'
<input checked="" type="checkbox"/>	Disable Job Select Key	Key 'JOB SELECT / DECREMENT (-)' pressed.	Key Handling , Consume = 'true'
<input checked="" type="checkbox"/>	Disable Test Print Key	Key 'TEST PRINT / INCREMENT (+)' pressed.	Key Handling , Consume = 'true'
<input checked="" type="checkbox"/>	Wait For Menu Key	Key 'MENU' pressed.	Send 'Pin Empty' to 'LCD Line 2', time is 'infinite'
<input checked="" type="checkbox"/>	Wait For Menu Key	Key 'MENU' pressed.	Select Mapping Table 'pin_part_1'

Figure 231 Power_On Mapping Table

Table 13 does not show all entries in a power-on table, just those that are important for the PIN number application. The first four entries disable the important keys; the action that normally would result from pressing the key will not execute. The Pause and Feed key are left unchanged but as soon as the menu key is pressed the specified actions execute. Since the first four keys specified are disabled, they are ignored. Next the pin_empty message displays in Line 2 of the LCD then the Pin_Part_1 mapping table is selected.

On	Description	Event	Action
<input checked="" type="checkbox"/>	Get Pause Key Value	Key 'PAUSE' pressed.	Field 'new_pin' += 'pause_key'
<input checked="" type="checkbox"/>	Get Minus Key Value	Key 'JOB SELECT / DECREMENT (-)' pressed.	Field 'new_pin' += 'minus_key'
<input checked="" type="checkbox"/>	Get Up Key Value	Key 'FEED / UP (^)' pressed.	Field 'new_pin' += 'up_key'
<input checked="" type="checkbox"/>	Get Plus Key Value	Key 'TEST PRINT / INCREMENT (+)' pressed.	Field 'new_pin' += 'plus_key'
<input checked="" type="checkbox"/>	Get Menu Key Value	Key 'MENU' pressed.	Field 'new_pin' += 'menu_key'
<input checked="" type="checkbox"/>	Get Down Key Value	Key 'CANCEL (X) / DOWN' pressed.	Field 'new_pin' += 'down_key'
<input checked="" type="checkbox"/>	Get Enter Key Value	Key 'ENTER' pressed.	Field 'new_pin' += 'enter_key'
<input checked="" type="checkbox"/>	Create Pin Number	Field 'new_pin' changed.	Field 'new_pin' = '10'
<input checked="" type="checkbox"/>	Show First Entry Done	Field 'new_pin' changed.	Send 'one_pin' to 'LCD Line 2', time is 'infinite'
<input checked="" type="checkbox"/>	Get Next Pin Digit	Field 'new_pin' changed.	Select Mapping Table 'pin_part_2'

Figure 232 Pin_Part_1 Mapping Table

If a key is pressed for the first 7 entries, the value of the related data field is added to the new_pin data field, which is multiplied by 10 to shift the content one decimal place over. Since we now have the first part of the PIN number in a data field, we'll display the one_pin message on the LCD and switch to the Pin_Part_2 table.

On	Description	Event	Action
<input checked="" type="checkbox"/>	Get Pause Key Value	Key 'PAUSE' pressed.	$\text{Field 'new_pin'} += \text{'pause_key'}$
<input checked="" type="checkbox"/>	Get Minus Key Value	Key 'JOB SELECT / DECREMENT (-)' pressed.	$\text{Field 'new_pin'} += \text{'minus_key'}$
<input checked="" type="checkbox"/>	Get Up Key Value	Key 'FEED / UP (^)' pressed.	$\text{Field 'new_pin'} += \text{'up_key'}$
<input checked="" type="checkbox"/>	Get Plus Key Value	Key 'TEST PRINT / INCREMENT (+)' pressed.	$\text{Field 'new_pin'} += \text{'plus_key'}$
<input checked="" type="checkbox"/>	Get Menu Key Value	Key 'MENU' pressed.	$\text{Field 'new_pin'} += \text{'menu_key'}$
<input checked="" type="checkbox"/>	Get Down Key Value	Key 'CANCEL (X) / DOWN' pressed.	$\text{Field 'new_pin'} += \text{'down_key'}$
<input checked="" type="checkbox"/>	Get Enter Key Value	Key 'ENTER' pressed.	$\text{Field 'new_pin'} += \text{'enter_key'}$
<input checked="" type="checkbox"/>	Create Pin Number	Field 'new_pin' changed.	$\text{Field 'new_pin'} = \text{'10'}$
<input checked="" type="checkbox"/>	Show Second Entry Done	Field 'new_pin' changed.	Send 'one_pin' to 'LCD Line 2', time is 'infinite'
<input checked="" type="checkbox"/>	Get Next Pin Digit	Field 'new_pin' changed.	Select Mapping Table 'pin_part_3'

Figure 233 Pin_Part_2 Mapping Table

The Pin_Part_2 mapping table is similar to the Pin_Part_1 mapping table. If a key is pressed for the first 7 entries, the value of the related data field is added to the new_pin data field, which is multiplied by 10. The message two_pin will display to indicate that two numbers of the PIN code have been entered and to select the Pin_Part_3 table.

On	Description	Event	Action
<input checked="" type="checkbox"/>	Get Pause Key Value	Key 'PAUSE' pressed.	$\text{Field 'new_pin'} += \text{'pause_key'}$
<input checked="" type="checkbox"/>	Get Minus Key Value	Key 'JOB SELECT / DECREMENT (-)' pressed.	$\text{Field 'new_pin'} += \text{'minus_key'}$
<input checked="" type="checkbox"/>	Get Up Key Value	Key 'FEED / UP (^)' pressed.	$\text{Field 'new_pin'} += \text{'up_key'}$
<input checked="" type="checkbox"/>	Get Plus Key Value	Key 'TEST PRINT / INCREMENT (+)' pressed.	$\text{Field 'new_pin'} += \text{'plus_key'}$
<input checked="" type="checkbox"/>	Get Menu Key Value	Key 'MENU' pressed.	$\text{Field 'new_pin'} += \text{'menu_key'}$
<input checked="" type="checkbox"/>	Get Down Key Value	Key 'CANCEL (X) / DOWN' pressed.	$\text{Field 'new_pin'} += \text{'down_key'}$
<input checked="" type="checkbox"/>	Get Enter Key Value	Key 'ENTER' pressed.	$\text{Field 'new_pin'} += \text{'enter_key'}$
<input checked="" type="checkbox"/>	Display Pin Correct Message	Field 'new_pin' changed and value == 'pin_number'	Send 'pin_accepted' to 'LCD Line 2', time is '2' s.
<input checked="" type="checkbox"/>	Switch Off GPIO	Field 'new_pin' changed and value == 'pin_number'	Disable GPIO Events
<input checked="" type="checkbox"/>	Display PIN Incorrect Message	Field 'new_pin' changed and value == 'pin_number'	Send 'incorrect_pin' to 'LCD Line 2', time is '2' s.
<input checked="" type="checkbox"/>	PIN Error Sound	Field 'new_pin' changed and value == 'pin_number'	Beep '3' times.
<input checked="" type="checkbox"/>	Track PIN Errors	Field 'new_pin' changed and value == 'pin_number'	$\text{Field 'pin_entry_count'} += \text{'1'}$
<input checked="" type="checkbox"/>	Last Error Allowed?	$\text{Field 'pin_entry_count'}$ changed and value == '3'	Select Mapping Table 'Printer Locked'
<input checked="" type="checkbox"/>	Next Try - Clear New PIN	$\text{Field 'pin_entry_count'}$ changed and value == '3'	$\text{Field 'new_pin'} = \text{'0'}$
<input checked="" type="checkbox"/>	Display Empty PIN	$\text{Field 'pin_entry_count'}$ changed and value == '3'	Send 'pin_empty' to 'LCD Line 2', time is 'infinite'
<input checked="" type="checkbox"/>	Try The Next One	$\text{Field 'pin_entry_count'}$ changed and value == '3'	Select Mapping Table 'pin_part_1'

Figure 234 Pin_Part_3 Mapping Table

The Pin_Part_3 mapping table starts with the same seven entries. The value is added to new_pin but this time we do not multiply the value by 10; we now have the complete PIN code. The message displayed depends on the result of the comparison between the new_pin data field and the pin_number data field. If the two values are the same, the message pin_accepted will display and GPIO will be disabled, allowing the printer to function as a normal printer. Configuration changes can be made and saved. A power cycle is required to reactivate GPIO and its printer protection function.

If the two numbers do not match the pin_incorrect message displays on the LCD. The printer will beep three times and the pin_error count increments. This value is tested to see if this was the third trial. If not, the user is given another try.

Event to Action Mapping - Thermal

Description: Uninterrupted

Event: Parameters...

Action: Parameters...

New
Add
Update

On	Description	Event	Action
<input checked="" type="checkbox"/>	Show Printer Locked	Table Entered	Send 'locked' to 'LCD Line 2', time is 'Infinite'
<input checked="" type="checkbox"/>	Inform Host, Printer Locked	Table Entered	Send 'locked' to 'Ethernet Adapter', 'Back Channel'
<input checked="" type="checkbox"/>	Render Printer Useless	Table Entered	Lock Panel

Figure 235 Prt_Locked Mapping Table

If it is the third try, the event generator timer starts and the Prt_Locked mapping table is selected. In this table we'll inform the user that the printer is locked by displaying the Printer Locked message on the LCD. We'll inform the host by sending a message through the interface and disable the operator panel, making it useless until a power cycle has been done.

The program could be easier to enter by using the new subroutine function. The seven entries related to the pressing of the keys to generate the PIN code could be made a subroutine. This would improve printer memory usage and save time on typing.

GPIO Version Control System

The Version Control System (VCS) allows you to assign an application name and add version information to the files. This information helps you easily identify the purpose of the files created and in which application. The VCS prints the application name and version information in the printer's configuration printout.

Application Name and Version Information

The application name is a logical user-defined name for the GPIO application and is stored inside the GPIO Configuration file. The maximum length is 16 characters.

The version information contains the following:

- **Version Number** – V<version>.<revision><release level>

where:

<version> = decimal number (1 ... n)

<revision> = decimal number (two digits: 00 ... 99)

<release level> = upper-case alphabetic character (A ... ZZ)

Examples: V1.00A (initial version), V2.06C, V3.21AA, V3.21BX.

- **Last Modification Date** - <month> - <day> - <year>

Indicates when the GPIO Configuration File was last modified.

- **File ID** – Unique 32-bit hexadecimal number (checksum).

NOTE: The VCS system cannot prevent the creation of two files that contain the same application name and version information but different content. To help identify such similar files, the Manager will include a checksum in the file.

Both the version number and last modification date are stored in the respective configuration file.

Creating a New File

When creating and saving a file for the first time, the Set Application Name dialog box opens prompting you to enter a logical name to identify the application.



Figure 236 Setting the GPIO Application Name

Opening an Existing File

When you select File -> Open, or upload a file from the printer, the VCS checks if the file contains version information. If not, a dialog box opens and prompts you to enter a logical application name. The version number is set to 1.00A. You can then start modifying the application.

Modifying an Existing File

After opening an existing file, the process of building and modifying the application starts. To save your work as a new file or subsequent modifications of an existing file, do the following:

- **Save As New File**

Select File -> Save As. The application name is already assigned and the version number is 1.00A. Select a folder name, enter a file name, and click Save. The file is then stored on disk.

- **Subsequent Saves**

Select File -> Save. The Version Confirmation dialog box opens with save options. See Figure 237.

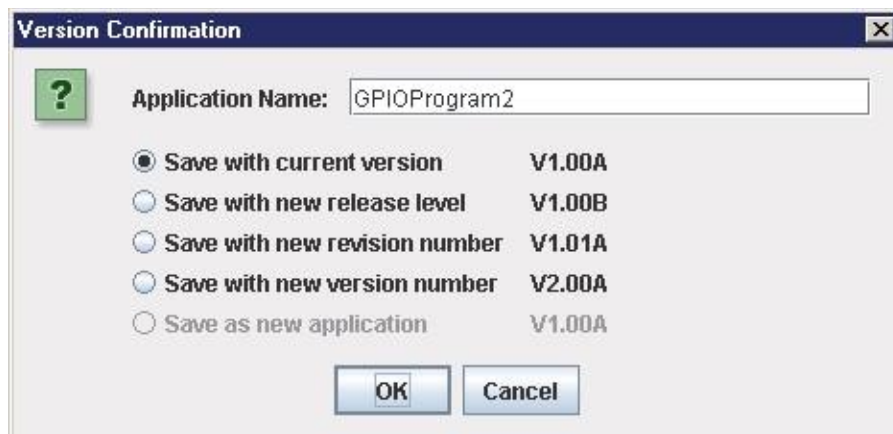

Figure 237 Confirming the File Version

NOTE: If you do not change the application name, the 'Save as new application' option is disabled. In this case, you must select one of the first four options. 'Save with current version' is the default selection.

If you change the application name, 'Save as new application' is enabled, allowing you to reset the version number to 1.00A.

The version numbers displayed with the options are the version numbers the GPIO Manager will store in the file.

NOTE: Version number increment rules.

When a file reaches release level Z and you select 'Save with new release level', the release level increments to AA.

For example, 1.01Z becomes 1.01AA.

When the release level reaches ZZ and the you select 'Save with new release level', the release level resets to A and the revision number increments. For example, 1.01ZZ becomes 1.02A.

When the revision number reaches 99 and you select 'Save with new revision number', the revision number resets to 00, the release level resets to A, and the version number increments.

For example, 1.99C becomes 2.00A.

Viewing File Version Information

To view version information of a file, select File -> Properties.



Figure 238 Viewing File Properties

Automatic File Backup System

The GPIO Manager automatically creates backups of the last 20 saved versions of a file. This backup system uses the file name (as specified in the File Save As ... dialog) to create the following file and folder structure:

< jav.user.dir\backup > - the java user directory is the PNE Auto ID install directory.

< File Name > - folder that will store the backups.

< ~ddmmyyyy_hhmmss>.bck - backup of the latest previous version of a file.

< ~ddmmyyyy_hhmmss>.bck - backup of the second latest previous version of a file

...

< ~ddmmyyyy_hhmmss>.bck - backup of the oldest previous version of the file.

Example:

```
File name = 'PTNX_SecurePrinting.gcf'  
< jav.user.dir\backup > PTNX_SecurePrinting  
~11042008_123145.bck  
~11042008_124432.bck  
...  
~11042008_145022.bck
```

Backup History

The GPIO Manager has a Backup History option that allows you to view the backup history of a file. The system maintains the last 20 versions of the file. This dialog has options to clear the history, open an older version, and save under a different file name.



Name	Version	Checksum	Date	Time	
_TestApp	V1.00A	1A7DC35A	22 Apr 2008	11:36:33	Created on save by GPI
_TestApp	V1.00A	CDE72AB9	22 Apr 2008	11:36:16	Created on save by GPI
_TestApp	V1.00A	E959FB8D	22 Apr 2008	11:36:01	Created on save by GPI
_TestApp	V1.00A	321C4A6B	22 Apr 2008	11:35:46	Created on save by GPI
_TestApp	V1.00A	143DAC4D	22 Apr 2008	11:35:37	Created on save by GPI
_TestApp	V1.00A	963EBFF7	22 Apr 2008	11:27:20	Created on save by GPI
_TestApp	V1.00A	1A7DC35A	22 Apr 2008	11:11:09	Created on save by GPI
_TestApp	V1.00A	E959FB8D	22 Apr 2008	11:10:12	Created on save by GPI
_TestApp	V1.00A	26F50315	22 Apr 2008	11:09:59	Created on save by GPI
_TestApp	V1.00A	1A7DC35A	22 Apr 2008	10:52:13	Created on save by GPI
_TestApp	V1.00A	1EDF0811	22 Apr 2008	10:38:24	Created on save by GPI
_TestApp	V1.00A	66F82EDF	22 Apr 2008	09:46:11	Created on save by GPI
Events-01	V1.00A	8C3AB8CB	16 Apr 2008	11:03:26	Created on save by GPI

Figure 239 Backup History Information

- Name - displays the application name assigned to the file at the time the backup was created.
- Version - displays the version assigned to the file at the time the backup was created.
- Checksum - displays the checksum calculated over the data of the file at the time the backup was created.
- Data and Time - shows when the backup file was created.
- Notes - displays which version of the GPIO manager the backup file was created.
- Clear button - clears the history.
- Open button - opens the backup file for editing.
- Save As button - saves a backup file under a different name to a local storage medium.
- Close button - closes the dialog.

Technical Information

Opto-couplers

The opto-couplers are Vishay SFH6916 or equivalent with the following basic specifications:

NOTE: Please check the Vishay SFH6916 datasheet for electrical specifications.

GaAs Light Emitting Diode

Reverse Voltage (Vr)	: 6 V
Forward Current (DC)	: 50 mA
Peak Forward Current (Ifp)	: 2.5 A

NPN Silicon Photo Transistor

Isolation Voltage (Vr)	: 3750 V r.m.s.
Collector to Emitter voltage (Vceo)	: 70 V
Collector current	: 50 mA

High switching speed

UL approved

The inputs of the GPIO board (the LEDs of 8 opto-couplers) are protected against overcurrent by the inclusion of a 4700 Ohm resistor in the anode connection. This allows for an input voltage range between 5 and 24 VDC.

The opto-coupler outputs are open collector transistors. By design the output current available is set at 3 ma. max. This value is based upon an opto-coupler current transfer ratio of 100% at an ambient temperature of 50 degrees C. Load currents greater than 3 ma. will cause the transistor to come out of the saturation, resulting in a rise in the output voltage and possible damage to the transistor. For safety purposes a voltage no greater than 42 volts DC should be applied to the GPIO board. The GPIO board has a provision for mounting resistors, either in the connection between the actual output pin and the collector of the output transistor or from a common connector pin (17) to the collector of the output resistor. See the drawing on page 247.

Relays

Relays are the NAI5 TX type and are 2-Amp high capacity relays with the following basic specifications:

NOTE: Please check the NAI5 TX type relay datasheet for complete electrical specifications.

Surge withstand between coil and contacts	: 2500 V
Breakdown voltage between coil and contact	: 2000 V
Nominal switching capacity	: 2 A @ 30 V
Maximum switching voltage	: 220 V DC
Maximum switching current	: 2 A
Contact settling time	: 4 mS (max)

The relays are type DPDT of which a single SPDT contact is made available on the I/O connector.

CAUTION For safety purposes do not apply a voltage greater than 42 volts DC to the GPIO board, even though the relay is rated at 220 volts DC.

Voltages

Two voltages available on the I/O connector are 5 and 24 volts DC. Using self-healing fuses, both voltages are separately fused at 500 mA for 5 volts and 250 mA for 24 volts. These voltages share the same ground. To guarantee complete galvanic isolation between the printer and the equipment that is

connected through the GPIO interface, use a separate power source for the equipment the printer is connected to and make sure the I/O connector housing on the printer side is not connected to ground.

NOTE: Be aware that the 24 volts require a special connection inside the printer and that this voltage is not available when a cutter is installed in the Thermal printer.

I/O Connector

The I/O connector is a 3 row, 50 pin, D type connector. Inputs and outputs of opto-couplers and relays are wired to this connector so that creating inputs using common anodes or cathodes or outputs using common emitters or collectors is fairly simple. The two voltages and their respective returns are also wired to this connector.

Table 14 specifies the connector wiring where IPxA represents the anode connection of the Input Opto Coupler diode and IPxC represents the cathode connection of the diode. OPxC represents the collector of the output transistor, and OPxE represents the emitter of the transistor. RxCM represents the common connection of the SPDT relay contact, RxNC represents the Normally Closed, and RxNO the Normally Open contact.

Table 14 Connector Wiring

1: IP1A	18: OP1C	34:R1CM
2: IP2A	19: OP2C	35:R2CM
3: IP3A	20: OP3C	36:R3CM
4: IP4A	21: OP4C	37:R4CM
5: IP5A	22: OP5C	38:R1NC
6: IP6A	23: OP6C	39:R2NC
7: IP7A	24: OP7C	40:R3NC
8: IP8A	25: OP8C	41:R4NC
9: IP1C	26: OP1E	42:R1NO
10: IP2C	27: OP2E	43:R2NO
11: IP3C	28: OP3E	44:R3NO
12: IP4C	29: OP4E	45:R4NO
13: IP5C	30: OP5E	46: n.c.
14: IP6C	31: OP6E	47:+5V
15: IP7C	32: OP7E	48:5Vret
16: IP8C	33: OP8E	49:+24V
17: (*)		50:24Vret

(*) Pin 17 is connected to a number of through holes on the GPIO printed circuit board. It can be used to supply power (via a user-installed resistor) to the collectors of the output transistors. See the diagram of the outputs on page 247.

Basic GPIO Schematic Diagram

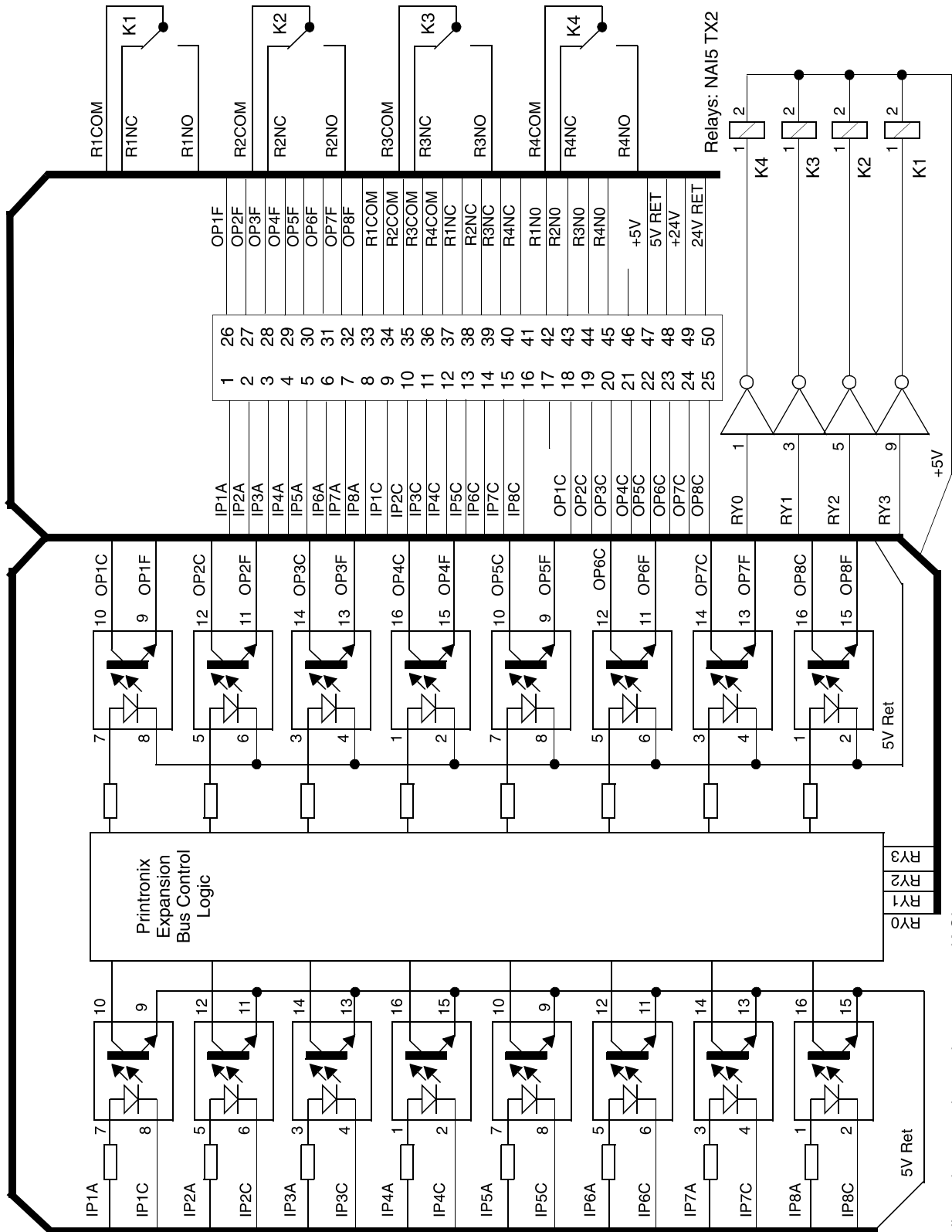

All anode protection resistors are 4.7K Ohms.

Electrical Inputs And Outputs

GPIO Opto-coupled Input Circuit

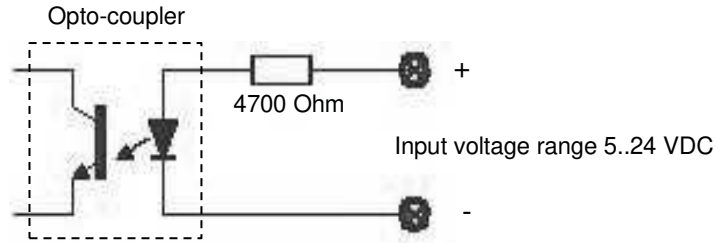

GPIO Opto-coupled Output Circuit

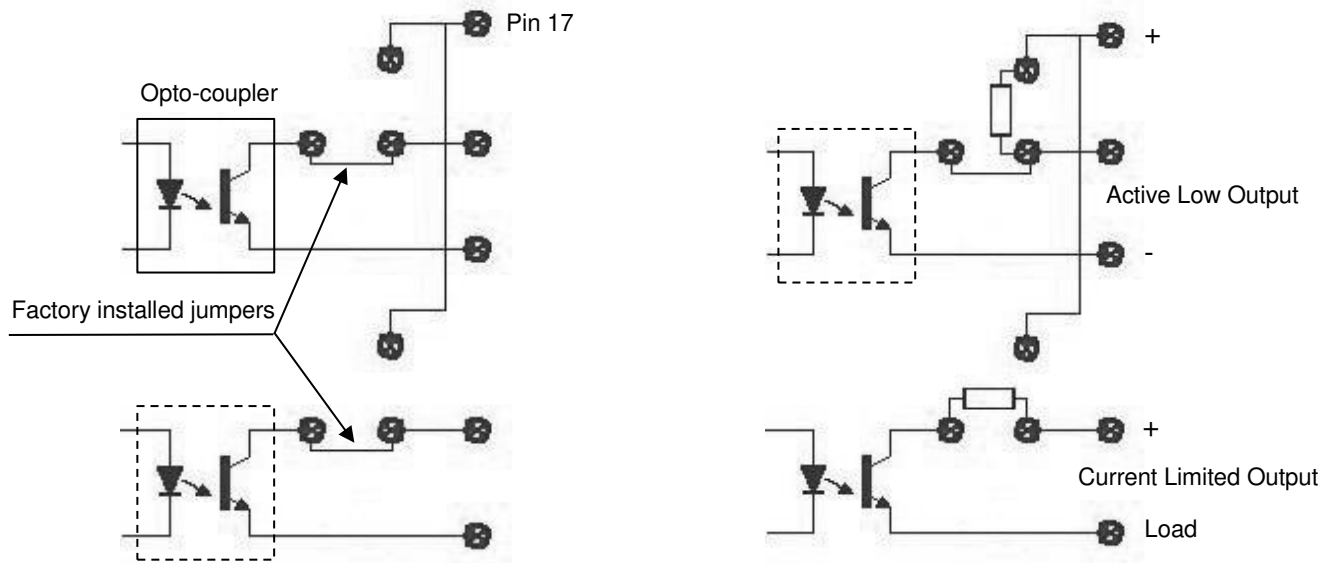

7 *AutoID Data Manager*

Overview

NOTE: You can set the AutoID Data Manager to launch automatically when PNE Auto ID launches. See Startup Tab on page 28.

The AutoID Data Manager is an application that can collect EPC (electronic product code) telemetry data (stored on Radio Frequency Identification [RFID] tags) from RFID enabled printers and can also simultaneously collect bar code telemetry data (printed on labels) from ODV (online data validator) enabled printers.

With this telemetry data (EPC and/or ODV), you can create compelling audits of label and RFID tag quality.

The AutoID Data Manager application performs the following functions:

- Collects telemetry data in a Data Capture file. From this file, you can generate reports in several formats: comma separated variable (CSV), extensible markup language (XML), and a predefined ASCII text file (for RFID data only).
- Exports telemetry data to a third-party database using Java database connectivity (JDBC).
- Places the printer into a fault state and display a custom message on the operator panel.

Data Validation

NOTE: To collect EPC telemetry data, you must set EPC Mgr Report to Enable (in the RFID CONTROL or RFID menu within the printer). Refer to the *RFID Labeling Reference Manual*.

To collect ODV telemetry data, you must set the printer's Telemetry Path to Network Port. See Set Telemetry Path (SL5000/T5000 Series Only) on page 14.

To access the AutoID Data Manager application, first select a printer or printers from the Printer Database that have an RFID encoder. Then select **Applications ► AutoID Data Manager** or click the  (AutoID Data Manager) button. The AutoID Data Manager window opens. See Figure 240.

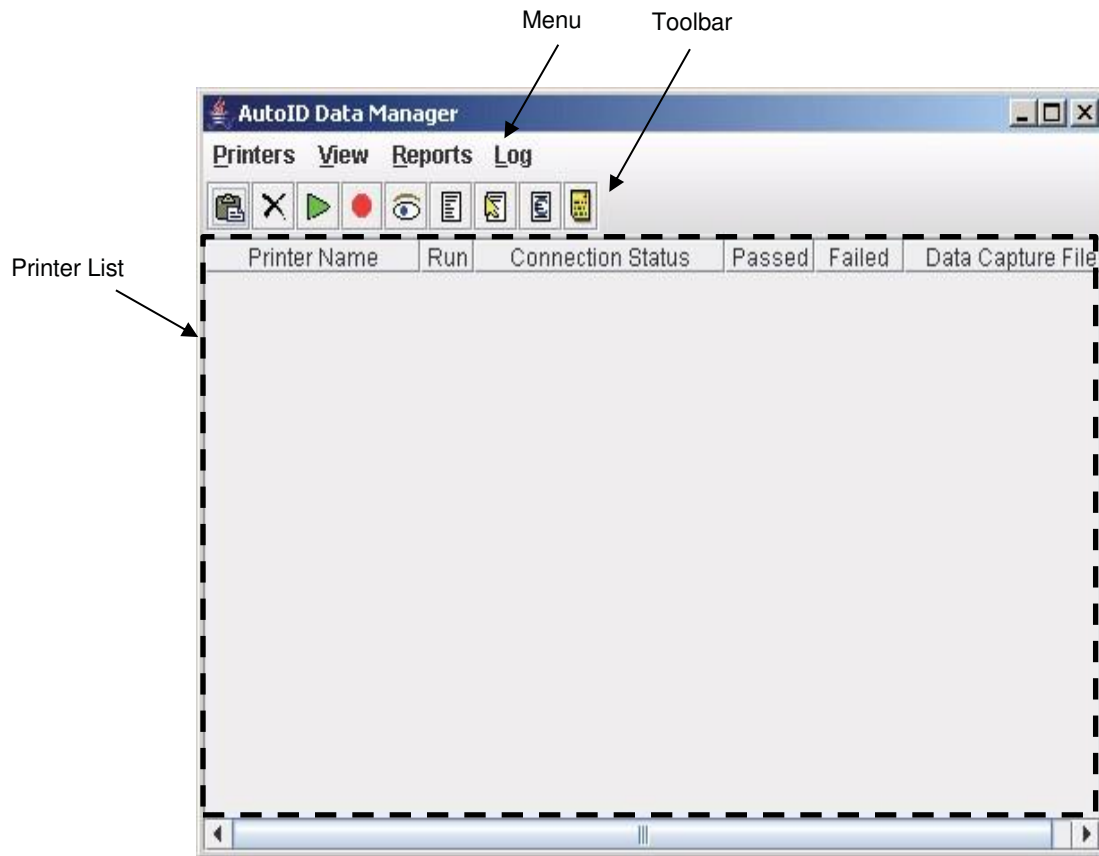

Figure 240 AutoID Data Manager Printer List Window

The Menu And Toolbar

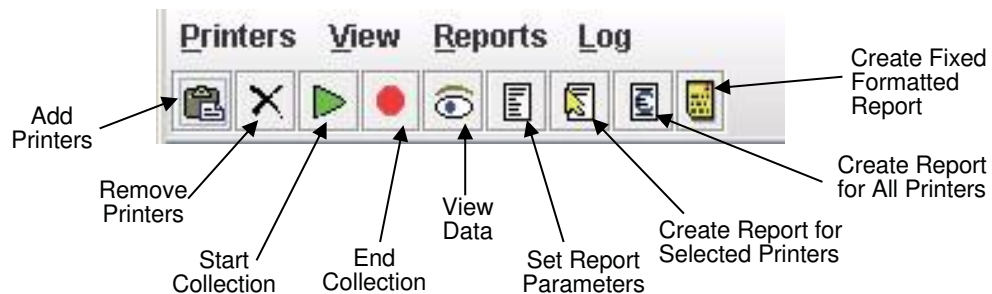

Figure 241 The Menu and Toolbar

Printers

Start Collection on All Printers: Starts the collection of telemetry data from all printers in the printer list.

End Collection on All Printers: Ends the collection of telemetry data from all printers in the printer list.

Add Printers Selected from Printer Database: Adds all printers that are selected in the Printer Database to the printer list. See Printer Database on page 23 and Printer List on page 251.

Remove Printers Selected from List: Removes all selected printers from the printer list.

Select Data Capture File: Allows you to change the Data Capture file name for a selected printer.

View

Data from Selected Printer: View telemetry data from the selected printer. See Viewing Telemetry Data on page 254.

NOTE: You can also double-click the printer in the printer list to view telemetry data. See Printer List on page 251.

NOTE: You cannot view telemetry data if the data is being sent to a 3rd party database. See Telemetry Data Export To 3rd Party Databases on page 265.

Reports

Set Report Parameters: Sets all of the report properties. You can select data fields, exclude items, select the report format type, and modify the report name and location. See Telemetry Data Export To 3rd Party Databases on page 265.

Create Report for Selected Printers: Creates an ASCII telemetry data file for all selected printers in the printer list, based on the Report Parameters settings.

Create Report for All Printers: Creates an ASCII telemetry data file for all printers in the printer list, based on the Report Parameters settings.

Create Standard RFID Text Report: Creates an ASCII telemetry data file for all selected printers in the printer list, based on predefined RFID fields.

Auto Report Generator: Allows daily, weekly, or monthly reports to be automatically generated at the given time and/or date.

NOTE: This Standard RFID Text report will not contain ODV data.

Log

Error Logging: Logs printer errors. Options include enabling or disabling error logging.

Printer List

When you add a printer, it appears in the printer list. See Figure 242.

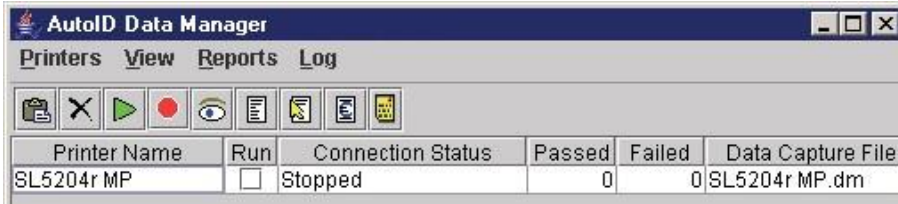

The screenshot shows the 'AutoID Data Manager' application window. It has a menu bar with 'Printers', 'View', 'Reports', and 'Log'. Below the menu bar is a toolbar with icons for adding, deleting, running, stopping, viewing, and logging. The main area contains a table with the following data:

Printer Name	Run	Connection Status	Passed	Failed	Data Capture File
SL5204r MP	<input type="checkbox"/>	Stopped	0	0	SL5204r MP.dm

Figure 242 A Printer Added to the Printer List

The AutoID Data Manager application remembers all printers in the printer list, even after you close the application.

NOTE: The only way to remove a printer from the printer list is to select it and click the  (delete printer) button or select **Printers ► Remove Printers Selected from List**.

Persistent Collection Mode

Check the **Run** check box to place the printer in persistent collection mode. In this mode, the printer will always connect and collect telemetry data without intervention. (Normally, you must start the collection of telemetry data by selecting the printer and clicking the  start collection button.)

NOTE: Checking or unchecking the **Run** check box immediately starts or stops the printer(s) from collecting telemetry data.

The next time you launch the AutoID Data Manager application, the AutoID Data Manager will immediately attempt to connect and collect telemetry data from all printers in persistent collection mode.

Data Capture File

A Data Capture file is created for every printer added to the printer list. All telemetry data is saved to this file, unless an external database is used to collect data.

To change the name or location of the Data Capture file, select

Printers ► Select Data Capture File. See Figure 243. When you change the Data Capture file name, all telemetry data is reset for the new file. Any existing telemetry data remains saved in the old Data Capture file name.

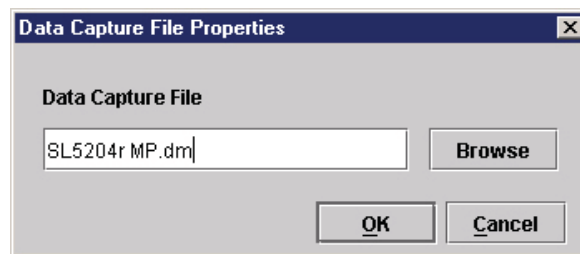

Figure 243 Data Capture File Properties Dialog Box

If you change the Data Capture file name to a name that already exists, the telemetry data stored in the existing file will not be erased. All new telemetry data will be appended to the existing file.

NOTE: You cannot change the Data Capture file name while telemetry data is being captured.

The AutoID Data Manager never erases the Data Capture file. To delete a Data Capture file, locate and delete the file from the default location, program installation directory, or where it was created (it has a **.dm** extension).

Report Generation

To export telemetry data to an ASCII file in either CSV or XML format, select a printer or group of printers and then select one of the report generation options (see Reports on page 251).

After the report is created, a dialog box appears giving the status, location, and name of the report. See Figure 244. Write down this information for future reference. Click **OK** to close the dialog box.



Figure 244 Report Creation Completed Dialog Box

Auto Report Generator

This feature allows PNE to generate csv reports for telemetry data automatically. Users can set frequency settings under Auto ID Data Manager -> Reports -> Auto Report Generator. The default setting is Manual. The daily setting generates a report every day at the specified time. The weekly setting generates a report once every week on the selected Day (M-S) and time. The monthly setting generates a report once every month on the selected time and Date.

The auto report generator can generate reports while the printer is collecting data. Under Preferences -> AutoID Data Manager -> Data File Option. If daily is selected, then the report generator will create a new data file after the report has generated. If legacy is selected, then the user must manually change the data capture file if desired. Data capture files and csv file names will have a date appended to create a unique filename.

Note: Auto ID Data Manger must be running in order to have the report generator running in the background.

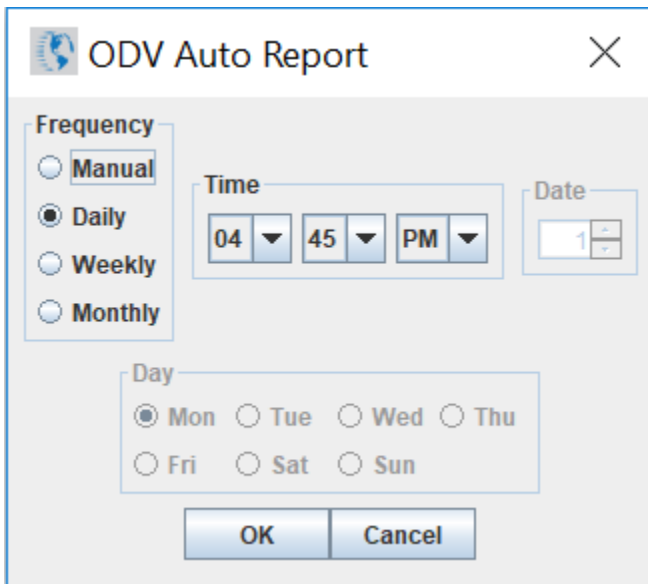

Figure 245 The AutoID Data Report Generator

Report Parameters

To export the telemetry data to an ASCII file, select a printer or group of printers, and then select either of the Reports options. The AutoID Data Report Parameters dialog box opens. See Figure 246.

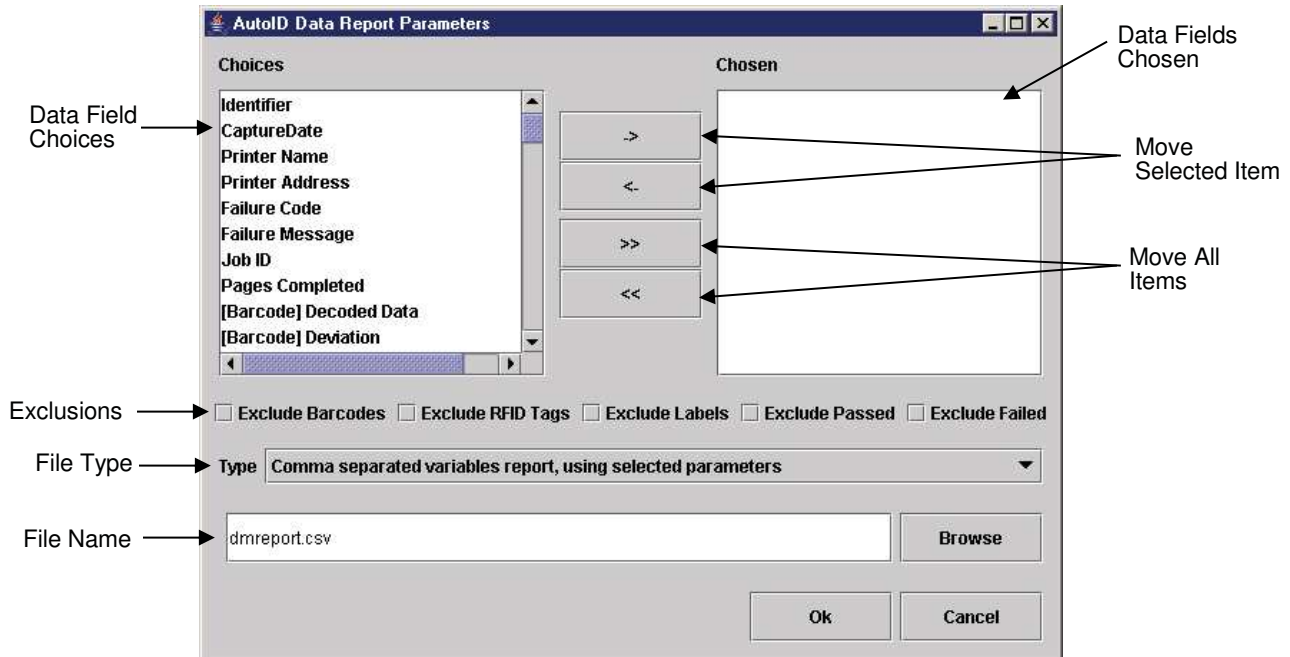

Figure 246 The AutoID Data Report Parameters Dialog Box

Select the data fields you wish to include in the report (one at a time) and click ->.

NOTE: You can select multiple data fields by using the **Ctrl** or **Shift** key.

If [Barcode] precedes the data field name, then it is exclusively for bar codes.

If [RFID] precedes the data field name, then it is exclusively for RFID tags.

If neither precedes the data field name, then it is a label field used for both bar codes and RFID tags.

You can later remove a data field from the report by selecting it and clicking <-. If you want to move all of them at once, click >> or <<. See Data Fields on page 258.

To exclude bar codes, RFID tags, labels, passed items, or failed items from the report, check the corresponding check box.

Using the Type down arrow, select a report type: comma separated variable or XML. See Comma Separated Variable Report on page 263 and XML Report on page 264.

Name the report using the Output File field. The default location is the program installation directory. Click **Browse** to save the file in a different location.

Once your report is set up, click **Ok** to save the report parameters.

Viewing Telemetry Data

NOTE: You cannot view telemetry data if the data is being sent to an external database. Data must be read using the database program. See Telemetry Data Export To 3rd Party Databases on page 265.

To view collected data from a printer, double-click the printer in the printer list (or select the printer and select **View Y Data from Selected Printer**). The AutoID Data Viewer window opens and collected telemetry data displays. See Figure 247.

Identifier

When viewing telemetry data, there is an identifier consisting of a letter followed by two numbers and separated by a decimal point. The letter **B** represents a bar code, **R** an RFID tag, and **L** a label.

For bar code and RFID tag identifiers (B and R), the first number represents the label number, and the second represents the bar code or RFID tag sequence number within the label. For label identifiers (L), the first number represents the label number, and the second specifies how many bar codes are on the label.

NOTE: Since a label typically has one RFID tag, this count is not included in the label identifier (L).

When viewing telemetry data, **B3.2** denotes the second bar code in the third label. **R5.1** denotes the first RFID tag in the fifth label. **L5.4** denotes the end of the fifth label, and the label has four bar codes. See Figure 247.

NOTE: The printer verifies the RFID tag before printing any bar codes. If the RFID tag fails, then the label automatically fails without any printed bar codes. See **R4.1** and **L4.0** in Figure 247.

Identifier	Failure	Deviation	Operation	Field	Data
R2.1	Pass		Write	EPC	48656C6C6F44565400000000
R2.1	Pass		Read	EPC	48656C6C6F44565400000000
B2.1	Defects	█			[ST]CODE39[ST]
L2.1	Fail (Label)				
R3.1	Pass		Write	EPC	48656C6C6F44565400000000
R3.1	Pass		Read	EPC	48656C6C6F44565400000000
B3.1	Pass	█			[ST]CODE39[ST]
B3.2	Pass	█			[ST]C39[ST]
B3.3	Pass	█			[ST]C39[ST]
B3.4	Pass	█			[ST]CODE39[ST]
L3.4	Pass (Label)				
R4.1	Tag Failure		Write	EPC	48656C6C6F44565400000000
L4.0	Fail (Label)				
R5.1	Pass		Write	EPC	48656C6C6F44565400000000
R5.1	Pass		Read	EPC	48656C6C6F44565400000000
B5.1	Pass	█			[ST]CODE39[ST]
B5.2	Pass	█			[ST]C39[ST]
B5.3	Pass	█			[ST]C39[ST]
B5.4	Pass	█			[ST]CODE39[ST]
L5.4	Pass (Label)				

File = New_Printer.dm Labels Only Au

Figure 247 Sample Telemetry Data

Viewing ODV Parameters

To view more information on your ODV results, click on ODV Parameters. Then, you can see a list of additional parameters to view. See New Figure.

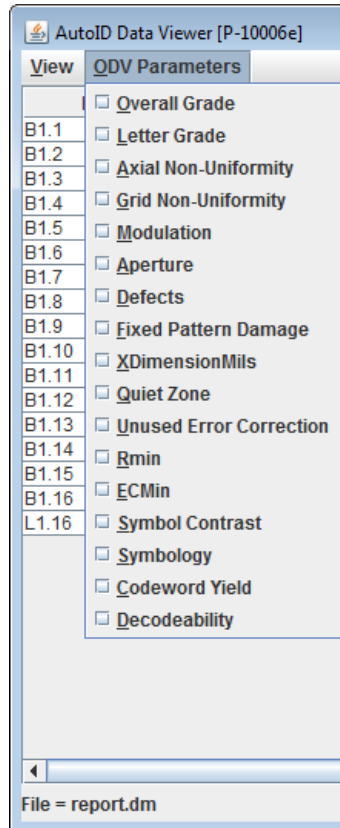

Figure 248 Sample Telemetry Data

Viewing Detailed Data

To view more detailed information about a label, bar code, or RFID tag, double-click the desired item under Identifier in the AutoID Data Viewer window. See Figure 249, Figure 250, Figure 251, and Figure 252.

Details for L5.4	
Parameter	Value
Format	Label
Identifier	L5.4
CaptureDate	Thu May 04 13:23:19 PDT 2006
Printer Name	New_Printer
Printer Address	10.224.2.64
Failure Code	0
Failure Message	Pass (Label)

Figure 249 Detailed Label Data

Details for L5.4	
Parameter	Value
Format	Extended Label
Identifier	L5.4
CaptureDate	Thu May 04 13:23:19 PDT 2006
Printer Name	New_Printer
Printer Address	10.224.2.64
Failure Code	0

Figure 250 Detailed Extended Label Data

Parameter	Value
Format	Barcode Long
Identifier	B5.2
CaptureDate	Thu May 04 13:23:18 PDT 2006
Printer Name	New_Printer
Printer Address	10.224.2.64
Failure Code	0
Failure Message	Pass
Decoded Data	[ST]C39[ST]
Deviation	-10
Symbology	Code 39
Letter Grade	B
Ref Decode	true
Decodeability Avg	77
Modulation Avg	87
Defects Avg	9

Figure 251 Detailed Barcode Long Data

Parameter	Value
Format	RFID Version 2
Identifier	R3.1
CaptureDate	Thu May 04 13:22:41 PDT 2006
Printer Name	New_Printer
Printer Address	10.224.2.64
Failure Code	0
Failure Message	Pass
RFID Tag Failure	false
Pre-Checked	false
Sequence Number	94
Retry Number	0
Error Count	0
Tag Type	Alien Squiggle 96
Failed Tag Count	30
Total Tag Count	3054
Data Length	12
Raw Data	48656C6C6F44565400000000
Total Data Length	12
Operation Type	Read
Field Type	EPC

RFID
Version 2
Only

Figure 252 Detailed RFID Version 2 Tag Data

Data Fields

NOTE: For the correct syntax for using the data field names in databases, see Data Field Names on page 272.

Over 70 data fields are available that describe bar code or RFID tag telemetry data. The first nine are defined as follows:

1. Format

This defines the type of record using an integer value.

Value	Description
Label	label status, older firmware (no longer supported)
Extended Label	label status, newer firmware
Barcode Short	bar code data, short format
Barcode Validation	bar code data, validation format
Barcode Long	bar code data, long format
RFID Version 1	RFID version 1 tag
RFID Version 2	RFID version 2 tag

2. Identifier

This identifies the RFID tag, bar code, and label number. See Identifier on page 254.

3. CaptureDate

This indicates the date and time the record was captured, using local time, in the format: Day, Month, Date, Time (00:00:00), Time Zone, and Year. See Figure 253.

Thu May 04 13:22:41 PDT 2006

Figure 253 CaptureDate Field Format

If the data is being sent to an external database, it is represented by a fixed format string defined as MM-dd-yyyy_HH:mm:ss where:

- MM is the month of the year (01-12)
- dd is the day of the month (01-31) yyyy is the year
- HH is the hour of the day (00-23)
- mm is the minutes of the hour
- SS is the seconds of the minute

4. Printer Name

This indicates the printer name as it appears in the Printer List window (see Figure 240 on page 250).

5. Printer Address

This is the IP address of the printer.

6. Failure Code

Bar Code

This is the hex value assigned for each type of failure, shown below. See 7. Failure Message on page 259.

Failure Code (Hex)	Failure Code (Binary)	Failure Message
0000	0000 0000 0000 0000	No error
0001	xxxx xxxx xxxx xxx1	PDF 417 Gap
0002	xxxx xxxx xxxx xx1x	Decodeability
0004	xxxx xxxx xxxx x1xx	Defect
0008	xxxx xxxx xxxx 1xxx	Percent Decode
0010	xxxx xxxx xxx1 xxxx	Quiet Zone
0020	xxxx xxxx xx1x xxxx	(Symbol) Contrast
0040	xxxx xxxx x1xx xxxx	Encodation
0080	xxxx xxxx 1xxx xxxx	Checksum
0100	xxxx xxx1 xxxx xxxx	Calibration
0200	xxxx xx1x xxxx xxxx	Overall Grade Failure
0400	xxxx x1xx xxxx xxxx	Internal Data Format Error
0800	xxxx 1xxx xxxx xxxx	Modulation
1000	xxx1 xxxx xxxx xxxx	Minimum Reflectance
2000	xx1x xxxx xxxx xxxx	Minimum Edge Contrast
4000	x1xx xxxx xxxx xxxx	Future use
8000	1xxx xxxx xxxx xxxx	Future use

NOTE: The hex values listed above reflect single failures. Multiple failures will create additional hex values based on the binary weighting shown.

For example, the hex value **0042** (or binary **0000 0000 0100 0010**) represents both the Encodation and Decodeability failures.

RFID

This is the hex value assigned for an RFID failure.

0 = no RFID failure

1 = RFID failure

7. Failure Message

Bar Code

Failure data is grouped into different types of failure, each of which defines a bar code problem.

- **Checksum:** This occurs when the bar code is not properly encoded with checksum digits.

- **Decodeability:** This occurs when the difference between wide and narrow elements is too close to reliably discern. This is generally an indication of an improperly set heat, speed, or pressure combination, or the loss of heating element.
- **Defects:** This is a measure of unexpected dark spots in spaces or light spots in bars. It is generally an indication of a poor ribbon or media combination, a burnt pixel, or the printhead needs cleaning.
- **Encodation:** This occurs when the bar code is not properly encoded. For example, a checksum is incorrect, a required number of characters is not met, or required terminator characters are missing. This is usually an indication of poor form or host application design.
- **Internal Data Format Error:** The bar code data format is invalid.
- **PDF 417 Gap:** This occurs when there are large gap damages (such as ribbon wrinkle, voids, spots, etc.) within the PDF 417 data body code.
- **Percent Decode:** This is a measure of consistency throughout the height of the bar code which indicates the number of good scans as a percentage of total scans. This is usually an indication of large blemishes within the code, such as with a wrinkle.
- **Quiet Zone:** This occurs when the minimum blank zone surrounding the bar code has not been met. This can typically occur in poorly designed forms where bar codes are placed too close to other elements, or the bar code is too close to an edge of the media, or the position of the media is shifting.
- **(Symbol) Contrast:** This occurs when the contrast between bars and spaces is not sufficient. This can be due to excessively light printing from too little heat on the printhead. It is also caused by colored media or ribbons.
- **Modulation:** This occurs when the ratio of the Minimum Edge Contrast and Symbol Contrast is below 40%.
- **Minimum Reflectance:** This occurs when the reflectance value for at least one bar in a bar code is not half or less than the highest reflectance value for a space.
- **Minimum Edge Contrast:** This error occurs when the Minimum Edge Contrast value is less than 15%.

In a bar code, each transition from a space to a bar (or a bar to a space) is an edge whose contrast is the difference between the peak values in the space and bar reflectance. Each edge in the bar code is measured, and the edge that has the minimum contrast is the Minimum Edge Contrast.

It is possible that more than one failure message can be reported in a bar code report. However, the printer can display only one error message at a time. Thus, when multiple failures are detected, only one message displays and the rest are ignored, based on the following failure priority hierarchy.

Priority	Failure Message	Operator Panel Message
1 (highest)	Encodation	Bar code improper data format
2	Checksum	Checksum Failure
3	Quiet Zone	Bar code quiet zone too small
4	(Symbol) Contrast	Contrast too low Check media
5	Percent Decode	Poor scanning Check media

6	Defects	Poor scanning Inspect head
7	Decodeability	Unscannable code Check media
8	PDF 417 Gap	Poor scanning Check media
9	Calibration	Calibratio n Warning
10	Overall Grade Failure	Overall Grade Failure
11	Internal Data Format Error	Error Data invalid
12	Modulation	Modulation Fail Check head&heat
13	Minimum Reflectance	RMin Fail Check head&heat
14 (lowest)	Minimum Edge Contrast	Edge Ctst Fail Check head&heat

Other Error Messages

- **Calibration Warning:** In some cases, the validator can determine if it is out of calibration. When this occurs, the validator will communicate this condition as part of a bar code report. This condition is considered a warning and the printer will not stop.

NOTE: If a bar code failure is also reported in the same bar code report, then failure error handling will take precedence.

When the calibration warning condition is encountered, the message “Validator needs calibration” displays. Normal operation will continue during this warning. To clear the message, press the **PAUSE** key.

Once the message has been cleared, perform the calibration procedure (see “Calibration” in the *Online Data Validator User’s Manual*). Whether or not you perform a calibration will be unknown to the printer. Once the warning message has been cleared, the printer will assume that any problem has been resolved and will function as normal.

- **Overall Grade Failure:** This is an overall data validation failure. One or more of the following errors has occurred: Decodeability, Percent Decode, Defects, Modulation, Minimum Edge Contrast (EC Min), Minimum Reflectance (Rmin), and/or (Symbol) Contrast.

The printer’s next action depends on the error action setting. If the Stop mode is selected, printing resumes where the printing stopped. If the Overstrike or Reprint modes are selected, the printer assumes the last label failed and takes the appropriate action. See “Error Action” in the *Online Data Validator User’s Manual*.

RFID

This is the message assigned for an RFID failure.

Pass = no RFID failure

Tag Failure = RFID failure

8. Job ID

The default is 65535. For future use.

9. Pages Completed

The default is 0. For future use.

Bar Code Data Fields

These are the available bar code data fields:

Decoded Data	Horizontal Position
Deviation	Vertical Position
Symbology	Good Scans on Code
Letter Grade	Total Scans on Code
Ref Decode	Good Quiet Zones
Decodeability Avg	Lead QZ In X's
Modulation Avg	Trail QZ In X's
Defects Avg	Sync State
Edge Contrast Avg	X Units Times 10
Rmin/Rmax Avg	Percent Good Global Thresholds
Symbol Contrast Avg	PDF 417 Gap Failure
PCS Avg	Decodeability Failure
R(White) Avg	Defects Failure
R(Black) Avg	Percent Decode Failure
Ratio Avg	Quiet Zone Failure
Bar Deviation Avg	Symbol Contrast Failure
Minimum Bar Dev Avg	Encodation Failure
Maximum Bar Dev Avg	Checksum Failure
Quiet Zone	Calibration Warning
Percent Decode Average	Overall Grade Failure
Absolute X Dimension	Internal Data Format Error
Overall Symbol Grade Avg	Modulation Failure
Direction	Minimum Reflectance Failure
Checksum	Minimum Edge Contrast Failure
Self Check	Disregard Quiet Zone Failures
Symbology and Addendum	Disregard Contrast Failures

For an introductory description of the bar code data fields, see the *Layman's Guide to ANSI X3.182*.

For a complete description, see the *ANSI INCITS 182-1990 (R2002) Guideline for Bar Code Print Quality* available from the American National Standards Institute at <http://www.ansi.org/>.

RFID Version 1 Data Fields

These are the available RFID Version 1 data fields:

RFID Tag Failure
Pre-Checked
Sequence Number
Retry Number
Error Count
Tag Type
Failed Tag Count
Tag Write Count
Data Length
Raw Data

Refer to the *RFID Labeling Reference Manual* for a description of these fields.

RFID Version 2 Data Fields

These are the available RFID Version 2 data fields:

RFID Tag Failure
Pre-Checked
Sequence Number
Retry Number
Error Count
Tag Type
Failed Tag Count
Tag Write Count
Data Length
Raw Data
Total Data Length
Operation Type
Field Type

Refer to the *RFID Labeling Reference Manual* for a description of these fields.

Comma Separated Variable Report

The comma separated variable report format can be easily imported into many database and spreadsheet programs.

The report consists of a description line (the first line in the report) that contains the names of the fields in the order of the data. Each field is separated by a comma. The exported data follow the description line. Each record of the report is placed on a separate line. See Figure 254.

```

CaptureDate,Type,Printer Name,Failure Message,Decoded Data,RFID Tag Failure,Tag Type,Failed Tag
10:36:20,4,SL5304e MP,Tag,0000162000000001,True,5,3,19,000016200000000107-14-2004 10:36:20,0,S
10:36:21,4,SL5304e MP,Pass,0000162000000001,False,5,3,20,000016200000000107-14-2004 10:36:22,0
10:36:22,4,SL5304e MP,Pass,0000162000000002,False,5,3,21,000016200000000207-14-2004 10:36:23,0
10:36:23,4,SL5304e MP,Pass,0000162000000003,False,5,3,22,000016200000000307-14-2004 10:36:24,0
10:36:24,4,SL5304e MP,Pass,0000162000000004,False,5,3,23,000016200000000407-14-2004 10:36:24,0
10:36:25,4,SL5304e MP,Pass,0000162000000005,False,5,3,24,000016200000000507-14-2004 10:36:25,0
10:36:26,4,SL5304e MP,Pass,0000162000000006,False,5,3,25,000016200000000607-14-2004 10:36:26,0
10:36:27,4,SL5304e MP,Pass,0000162000000007,False,5,3,26,000016200000000707-14-2004 10:36:27,0
10:36:27,4,SL5304e MP,Pass,0000162000000008,False,5,3,27,000016200000000807-14-2004 10:36:28,0
10:36:28,4,SL5304e MP,Pass,0000162000000009,False,5,3,28,000016200000000907-14-2004 10:36:29,0
10:36:29,4,SL5304e MP,Pass,0000162000000010,False,5,3,29,000016200000001007-14-2004 10:36:30,0
10:36:30,4,SL5304e MP,Pass,0000162000000011,False,5,3,30,000016200000001107-14-2004 10:36:31,0
10:36:31,4,SL5304e MP,Pass,0000162000000012,False,5,3,31,000016200000001207-14-2004 10:36:31,0
10:36:32,4,SL5304e MP,Pass,0000162000000013,False,5,3,32,000016200000001307-14-2004 10:36:32,0
10:36:33,4,SL5304e MP,Pass,0000162000000014,False,5,3,33,000016200000001407-14-2004 10:36:33,0

```

Figure 254 Sample Comma Separated Variable Report

XML Report

The XML report format conforms to a well formed XML document as defined in *W3C Recommendation, Extensible Markup Language (XML) 1.0* available from the World Wide Web Consortium at <http://www.w3c.org/>.

You can view the XML report using any XML viewer. See Figure 255.

```

<?xml version="1.0" encoding="UTF-8"?>
<PrintronixDataValidation Version="1.0" SaveDate="July 14, 2004 10:38:30 AM PDT">
  <Data>
    <Label CaptureDate="07-14-2004 10:36:22" Type="0" PrinterName="SL5304e MP" FailureMess.
      <RFID CaptureDate="07-14-2004 10:36:21" Type="4" PrinterName="SL5304e MP" FailureMes:
RfidTagFailure="False" RfidTagType="5" RfidFailedTagCount="0" RfidTotalTagCount="20" RfidR:
    </Label>
    <Label CaptureDate="07-14-2004 10:36:23" Type="0" PrinterName="SL5304e MP" FailureMess.
      <RFID CaptureDate="07-14-2004 10:36:22" Type="4" PrinterName="SL5304e MP" FailureMes:
RfidTagFailure="False" RfidTagType="5" RfidFailedTagCount="0" RfidTotalTagCount="21" RfidR:
    </Label>
    <Label CaptureDate="07-14-2004 10:36:24" Type="0" PrinterName="SL5304e MP" FailureMess.
      <RFID CaptureDate="07-14-2004 10:36:23" Type="4" PrinterName="SL5304e MP" FailureMes:
RfidTagFailure="False" RfidTagType="5" RfidFailedTagCount="0" RfidTotalTagCount="22" RfidR:
    </Label>
    <Label CaptureDate="07-14-2004 10:36:24" Type="0" PrinterName="SL5304e MP" FailureMess.
      <RFID CaptureDate="07-14-2004 10:36:24" Type="4" PrinterName="SL5304e MP" FailureMes:
RfidTagFailure="True" RfidTagType="5" RfidFailedTagCount="1" RfidTotalTagCount="23" RfidRa:
    </Label>
  </Data>
</PrintronixDataValidation>

```

Figure 255 Sample XML Report

Standard RFID Text Report

The Standard RFID Text Report is a predefined set of RFID data fields written in ASCII text. See Figure 256.

```

*****
Printer Name      Printer Address
Thermal Warehouse 10.224.2.64

Total Read/ Label RFID Failed Data
Tag Write Event Tag Tag Byte
Encoded Date Count (R/W) Number Encoded Count Length Tag Type Raw Data

08-08-2007 01:04:46 1 (W) 40 Pass 0 12 Alien Squiggle 96 48656C6C6F44565400000000
08-08-2007 01:04:46 1 (R) 41 Pass 0 12 Alien Squiggle 96 48656C6C6F44565400000000
08-08-2007 01:04:48 2 (W) 42 Pass 0 12 Alien Squiggle 96 48656C6C6F44565400000000
08-08-2007 01:04:48 2 (R) 43 Pass 0 12 Alien Squiggle 96 48656C6C6F44565400000000
08-08-2007 01:04:51 3 (W) 44 Pass 0 12 Alien Squiggle 96 48656C6C6F44565400000000
08-08-2007 01:04:51 3 (R) 45 Pass 0 12 Alien Squiggle 96 48656C6C6F44565400000000
08-08-2007 01:04:53 4 (W) 46 Pass 0 12 Alien Squiggle 96 48656C6C6F44565400000000
08-08-2007 01:04:53 4 (R) 47 Pass 0 12 Alien Squiggle 96 48656C6C6F44565400000000
08-08-2007 01:04:56 5 (W) 48 Pass 0 12 Alien Squiggle 96 48656C6C6F44565400000000
08-08-2007 01:04:56 5 (R) 49 Pass 0 12 Alien Squiggle 96 48656C6C6F44565400000000

Total Tag Count For Selected Time Period => 5
Total Failed Tag Count For Selected Time Period => 0
Percent Yield For Selected Time Period => 100%

*****

End Of Report

```

Figure 256 Sample Standard RFID Text Report

Telemetry Data Export To 3rd Party Databases

The AutoID Data Manager allows you to export telemetry data to 3rd party databases using the JDBC interface. To export telemetry data, you need to obtain either a JDBC or an ODBC driver from your database vendor.

When configured, the 3rd party database opens when the Data Validation Printers List window opens, and closes when the window closes. Any telemetry data collected by the AutoID Data Manager is sent to the database.

NOTE: All external database errors are written to the file **odv_db.err**, located in the program installation directory.

The database connection is defined by four Java system property definitions that are placed in a global properties file called **pm.pro**. This file must be placed in the program installation directory.

NOTE: The **pm.pro** file is read only when the AutoID Data Manager initially loads. Any changes made to **pm.pro** are not reflected in the AutoID Data Manager until you relaunch the application.

Java system properties are name/value pairs, where the name and value are separated by an equal sign. The following four properties must be defined:

1. OdvJdbcDriver (Driver Class Property)

This is the name of the JDBC driver classfile. This value depends on the type of database being used, and is provided by the database or driver manufacturer. Also, some drivers require a JAR file be placed in the program installation classpath. This is done by renaming the driver JAR file to **jdbcdriver.jar** and placing it in the **lib** subdirectory found in the program installation directory. If you are using an ODBC driver, then you need to specify the JDBC-ODBC bridge supplied by Sun Microsystems® called **sun.jdbc.odbc.JdbcOdbcDriver**.

2. OdvJdbcUrl (Database URL)

This is the Uniform Resource Locator (URL) that describes the database being used. It depends on the database and driver being used, and its format is defined by the database or driver vendor.

The URL is a single line of text that follows the HTTP convention. It begins with the service identifier, **jdbc:**. Next, the service name is appended. For a JDBC compatible database, such as MySQL, the URL is **jdbc:mysql:**. For a normal ODBC compatible database, the URL is **jdbc:odbc:**.

Following the service name is the URL of the database, the user ID, and password used to log into the database.

3. **OdvJdbcDbName** (Database Name)

This is the name of the database table created to store the telemetry values. For a standard database, it is a single word. For an Excel[®] spreadsheet, it must be delimited by square brackets, e.g., **[Sheet1\$]**.

4. **OdvJdbcDbFields** (Database Fields List)

This is a comma separated list of database field names that correspond to the fields defined when the database or spreadsheet was created. Any field names in this list must match an AutoID property name.

IMPORTANT **The field names are case-sensitive. Make sure the field names selected are spelled correctly and are set to the maximum field sizes as shown in the tables on page 272.**

See Data Field Names on page 272 for a list of the acceptable AutoID property names (database name) that can be used.

5. **OdvJdbcPreparedStatement** (Optional property)

This optional property allows the user to explicitly define the SQL prepared statement, as defined in the JDBC specification. If it is not defined, a standard SQL **INSERT** statement is created using the table name (from the **OdvJdbcDbName** property) and the fields (from the **OdvJdbcDbFields** property).

For example, a table named **mytable** with the fields **CaptureDate**, **FailureCode**, and **DecodedData** would create the following statement:

```
INSERT INTO mytable(CaptureDate,FailureCode,DecodedData) VALUES(?,?,?)
```

Examples Of Property Definitions

NOTE: For all databases, make sure that zero length strings are allowed.

The following are some examples of property definitions. Printronix Auto ID does not guarantee that the examples shown will work for your database. Each database can have different drivers and connectivity requirements. The examples are provided to assist you in starting your property definition file. In the examples, the following values are used:

Database = odv

User ID = odvuser

Password = odvpassword

Table name = events

MySQL

OdvJdbcDriver=org.gjt.mm.mysql.Driver

OdvJdbcUrl=jdbc:mysql://mymachine/odv?user=odvuser&password= odvpassword

OdvJdbcDbName=events **OdvJdbcDbFields**=CaptureDate,FailureCode,DecodedData

SAP

OdvJdbcDriver=com.sap.dbtech.jdbc.DriverSapDB

OdvJdbcUrl=jdbc:sapdb:odv?user=odvuser&password=odvpassword

OdvJdbcDbName=events

OdvJdbcDbFields=CaptureDate,FailureCode,DecodedData

Microsoft® Access™

OdvJdbcDriver=sun.jdbc.odbc.JdbcOdbcDriver

OdvJdbcUrl=jdbc:odbc:odv;UID=odvuser&PWD=odvpassword

OdvJdbcDbName=events

OdvJdbcDbFields=CaptureDate,FailureCode,DecodedData

NOTE: **Date** is a reserved word in Microsoft Access.

Microsoft Excel

OdvJdbcDriver=sun.jdbc.odbc.JdbcOdbcDriver

OdvJdbcUrl=jdbc:odbc:odv

OdvJdbcDbName=[Sheet1\$]

OdvJdbcDbFields=CaptureDate,FailureCode,DecodedData

Example Exporting Telemetry Data To A Microsoft Access Database

This example shows how to create an Access database, connect it to the AutoID Data Manager, and have the AutoID Data Manager export captured telemetry data to the database.

To create an Access database:

1. Open Microsoft Access.
2. Select **File ► New Database** to create a new database named **odv**. (Use the **Blank** database template.)
3. Click **New** to create a new table. Select **Design View**.
4. Name the first field **ID** and define it as an **AutoNumber** field. This is required since the database must have a unique key value for each record. Each record sent from the AutoID Data Manager will be appended to the database and the data in this field will be one greater than the value in the previous record.

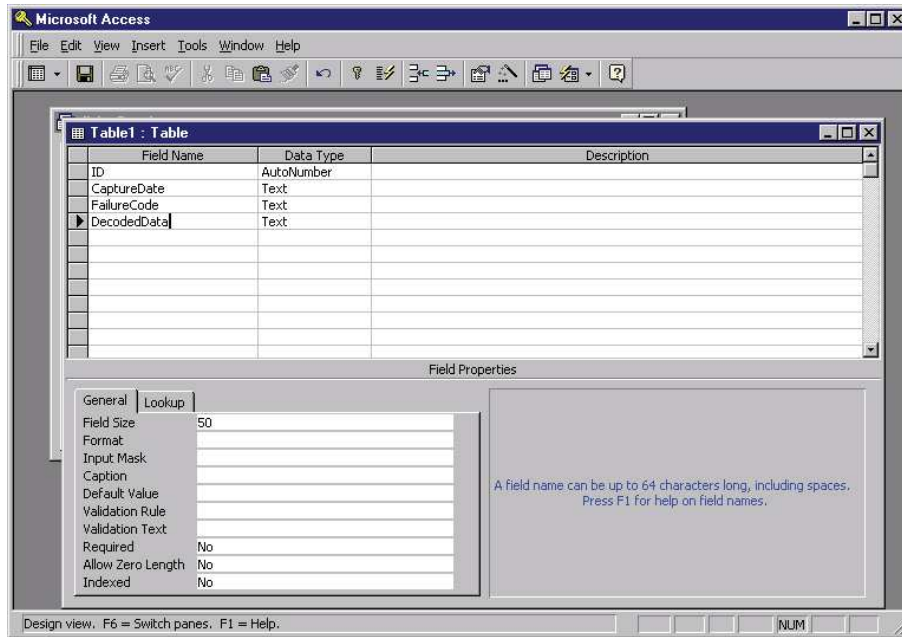

Figure 257 Adding Fields Using Design View in Microsoft Access

5. Name the next three fields **CaptureDate**, **FailureCode**, and **DecodedData**, and define them as **Text** data types. See Figure 257.

NOTE: Beginning with the second field, the field names must match the order of the fields specified in the `OdvJdbcDbFields` property. In this example, the `OdvJdbcDbFields` would be defined as `OdvJdbcDbFields=CaptureDate,FailureCode,DecodedData`.

6. Save the table as **events**.
7. Save the database as **odv**.
8. Open the Control Panel and double-click **Data Sources (ODBC)**.

NOTE: In Windows[®] 2000, double-click Administrative Tools, then Data Sources (ODBC).

In Windows XP, click Performance and Maintenance, then Administrative Tools, then Data Sources (ODBC).

9. Click the **System DSN** tab.
10. Click **Add** to create a new System DSN (Data Source Name) entry. This way the database can be accessed by the AutoID Data Manager running on a workstation that is not running the database.
11. Select **Microsoft Access Driver** from the driver list and click **Finish**. (If the driver is not listed, you need to install the driver before continuing.)

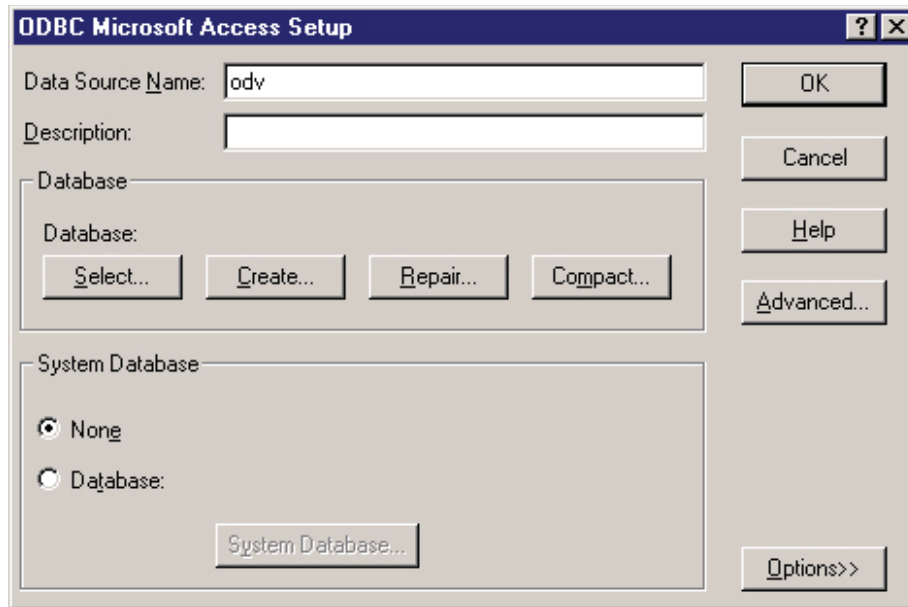

Figure 258 Entering the Data Source Name

12. Type **odv** in the **Data Source Name** field. See Figure 258.
13. Click **Select** to specify the **odv** database that you created.
14. Click **Advanced** to specify the username (odvuser) and password (odvpassword) to access the database.
15. Using Notepad, create an AutoID Data Manager properties file named **pm.txt** that contains the following text:

```
OdvJdbcDriver=sun.jdbc.odbc.JdbcOdbcDriver
OdvJdbcUrl=jdbc:odbc:odv;UID=odvuser&PWD=odvpassword
OdvJdbcDbName=events
OdvJdbcDbFields=CaptureDate,FailureCode,DecodedData
```
16. Rename the file **pm.txt** to **pm.pro** and place it into the program installation directory.
17. Run the AutoID Data Manager and collect the telemetry data. The collected telemetry data will be inserted into the **odv** database.

Exporting Telemetry Data To A Microsoft SQL Database

Here is the set up for the Microsoft SQL database using ODBC connectivity:

1. Using Notepad, create an AutoID Data Manager properties file named **pm.txt** that contains the following text:

```
# Microsoft SQL Connection Using ODBC
OdvJdbcDriver=sun.jdbc.odbc.JdbcOdbcDriver
OdvJdbcUrl=jdbc:odbc:odvsq
OdvJdbcDbName=events
OdvJdbcDbFields=PrinterAddress,DecodedData
```
2. Rename the file **pm.txt** to **pm.pro** and place it into the program installation directory.
3. SQL database name is **odvsq**.

4. Table name is **events**.
5. Field names: **PrinterAddress, DecodedData**
6. Make sure the SQL ODBC driver is in the Windows Data Sources – ODBC. You can use either Client or Server, depending on where the AutoID Data Manager resides.
7. Use the same Jar files from the default AutoID Manager.
8. Make sure the SQL database has the same field names as **pm.pro**.
9. Make sure that you use **window authentication**.
10. Run the AutoID Data Manager and collect the telemetry data. The collected telemetry data will be inserted into the **odvsqI** database.

User Fault Generation

User fault generation is a feature that allows 3rd party applications to stop the printing operation and display a sixteen character message on the printer's operator panel.

Using this feature in conjunction with the telemetry data export function allows external programs to implement a closed-loop telemetry data solution. If the external program detects an error, it can terminate all further printing to reduce bad labels and label stock waste.

The AutoID Data Manager provides this feature through the XML remote control interface. If a properly formatted XML message is sent to the AutoID Data Manager XML port, it will cause the AutoID Data Manager to issue a printer fault command to the specified printer. The fault command will cause the printer to go offline and display a 16 character text message on the printer's operator panel.

The following is the proper XML message format needed to generate a user fault:

^B

<ppmXML>

```
<PrinterFault printerName="myprinter" type="some message" />
```

</ppmXML>

^F

where:

myprinter is the name of the printer specified in the printer database

some message is the text message to be displayed on the printer's operator panel.

NOTE: The maximum length of the text message is 16 characters. Messages longer than 16 characters will be truncated.

How To Generate A User Fault

To generate a user fault, the AutoID Data Manager must be running. In addition, a properly formatted XML message must be transmitted to the XML server port defined in the printer database Preferences.

The default XML server port is 8081, but since this port number is user configurable, it is important to verify the XML server port number before sending the user fault message.

To verify the setting of the XML server port:

1. Open PNE Auto ID.
2. Select **File ► Preferences**.
3. Click the **Servers** tab.

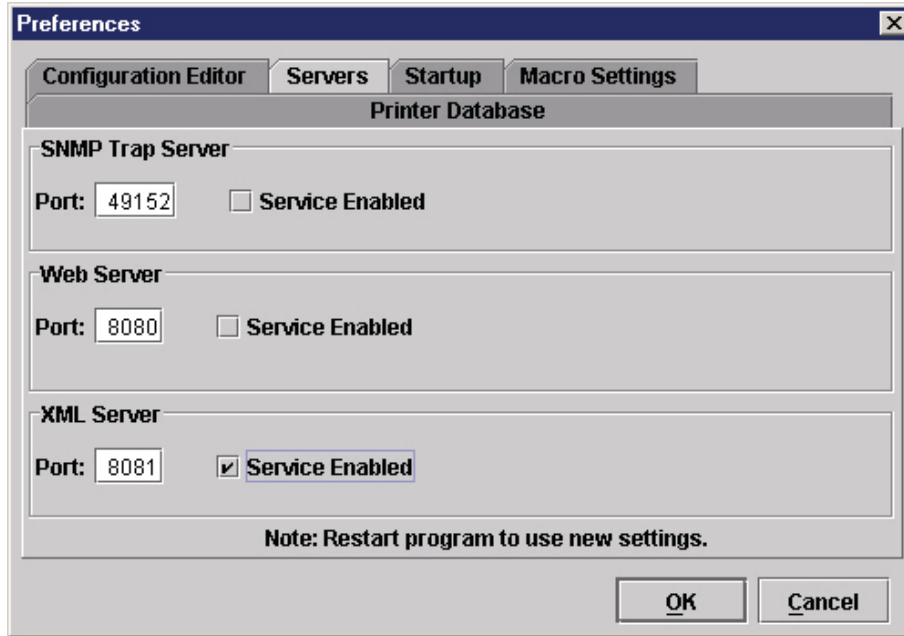

Figure 259 Enabling the XML Server Port

4. Make sure the **Service Enabled** check box is checked under **XML Server**. See Figure 259.

NOTE: If the box was not checked, you must quit and restart PNE Auto ID and the AutoID Data Manager to use the new setting.

5. Record the port number used by the XML server.

To send an XML message to the AutoID Data Manager, you need to open a telnet session to the XML server port. Once you have opened a telnet session, you can type in the XML message to generate the printer fault.

NOTE: To automate the fault generation process, you can develop an application that will send the properly formatted XML message.

Data Field Names

The following is a list and of all available telemetry data fields. The first column lists the names of the data fields as they appear in the Report Parameters window (page 253) and the detailed label, bar code, and RFID telemetry data windows (page 255). The second column lists the names of the data fields for databases.

Label Data Fields

Table 15 Label Data Fields

Name	Database Name	Maximum Database Field Size (Bytes)	Description
Format	Format	18	Format type: Barcode Short, Barcode Long, Barcode Validation, Label, Label Extended, RFID Version 1, RFID Version 2
Identifier	Identifier	12	The identifier is a type letter, a label number, a period, and sequence number for that label.
CaptureDate	CaptureDate	19	Date the data was captured. Formatted as 12/30/2008 12:59:59
Printer Name	PrinterName	32	The name of the printer defined in the printer database.
Printer Address	PrinterAddress	15	The IP address of the printer, either a dotted four octet number or a DNS resolved name.
Failure Code	FailureCode	5	The failure code number. Barcode or RFID failure codes are defined in respective product specification. Label failure codes: bit 0 = failure bit 1 = quiet zone failures ignored bit 2 = contrast failures ignored
Failure Message	FailureMessage	55	Text describing the highest priority failure.

Table 16 Extended Label Format Data Fields

Name	Database Name	Maximum Database Field (Bytes)
Format	Format	18
Identifier	Identifier	12
Capture Date	CaptureDate	19
Printer Name	PrinterName	32
Printer Address	PrinterAddress	15
Failure Code	FailureCode	5
Failure Message	FailureMessage	55
Job ID	JobID	5
Pages Completed	PagesCompleted	4

Bar Code Data Fields**Table 17 Bar Code Data Fields**

Name	Database Name	Maximum Database Field Size (Bytes)
Decoded Data	DecodedData	256
Deviation	Deviation	3
Symbology	Symbology	25
Letter Grade	LetterGrade	1
Ref Decode	RefDecode	5
Decodeability Avg	DecodeabilityAvg	3
Modulation Avg	ModulationAvg	3
Defects Avg	DefectsAvg	3
Edge Contrast Avg	EdgeContrastAvg	3
Rmin/Rmax Avg	RminRmaxAvg	3
Symbol Contrast Avg	SymbolContrastAvg	3
PCS Avg	PCSAvg	3
R(White) Avg	RWhiteAvg	3
R(Black) Avg	RBlackAvg	3

Table 17 Bar Code Data Fields

Name	Database Name	Maximum Database Field Size (Bytes)
Ratio Avg	RatioAvg	3
Bar Deviation Avg	BarDeviationAvg	3
Minimum Bar Dev Avg	MinimumBarDevAvg	3
Maximum Bar Dev Avg	MaximumBarDevAvg	3
Quiet Zone	QuietZone	5
Percent Decode Average	PercentDecodeAverage	3
Absolute X Dimension	AbsoluteXDimension	4
Overall Symbol Grade Avg	OverallSymbolGradeAvg	3
Direction	Direction	5
Checksum	Checksum	4
Self Check	SelfCheck	8
Symbology and Addendum	SymbologyAndAddendum	5
Horizontal Position	HorizontalPosition	5
Vertical Position	VerticalPosition	5
Good Scans on Code	GoodScansOnCode	4
Total Scans on Code	TotalScansOnCode	4
Good Quiet Zones	GoodQuietZones	4
Lead QZ in X's	LeadQzInXs	3
Trail QZ in X's	TrailQzInXs	3
Sync State	SyncState	5
X Units Times 10	XUnitsTimes10	3
Percent Good Global Thresholds	PercentGoodGlobalThresholds	3
PDF 417 Gap Failure	PDF417GapFailure	5
Decodeability Failure	DecodeabilityFailure	5

Table 17 Bar Code Data Fields

Name	Database Name	Maximum Database Field Size (Bytes)
Defects Failure	DefectsFailure	5
Percent Decode Failure	PercentDecodeFailure	5
Quiet Zone Failure	QuietZoneFailure	5
Symbol Contrast Failure	SymbolContrastFailure	5
Encodation Failure	EncodationFailure	5
Checksum Failure	ChecksumFailure	5
Calibration Warning	CalibrationWarning	5
Overall Grade Failure	OverallGradeFailure	5
Internal Data Format Error	InternalDataFormatError	5
Modulation Failure	ModulationFailure	5
Minimum Reflectance Failure	MinimumReflectanceFailure	5
Minimum Edge Contrast Failure	MinimumEdgeContrastFailure	5
Disregard Quiet Zone Failures	DisregardQuietZoneFailures	5
Disregard Contrast Failures	DisregardContrastFailures	5

RFID Data Fields

Table 18 RFID Version 1 Data Fields

Name	Database Name	Maximum Database Field Size (Bytes)
RFID Tag Failure	RfidTagFailure	5
Pre-Checked	RfidPrechecked	5
Sequence Number	RfidSequenceNumber	5
Retry Number	RfidRetryNumber	3
Error Count	RfidErrorCount	3
Tag Type	RfidTagType	32
Failed Tag Count	RfidFailedTagCount	10
Tag Write Count	RfidTagWriteCnt	10
Data Length	RfidDataLength	5
Raw Data	RfidRawData	56

Table 19 RFID Version 2 Fields

Name	Database Name	Maximum Database Field Size (Bytes)
RFID Tag Failure	RfidTagFailure	5
Pre-Checked	RfidPrechecked	5
Sequence Number	RfidSequenceNumber	5
Retry Number	RfidRetryNumber	3
Error Count	RfidErrorCount	3
Tag Type	RfidTagType	32
Failed Tag Count	RfidFailedTagCount	10
Tag Write Count	RfidTagWriteCnt	10
Data Length	RfidDataLength	5
Raw Data (see NOTE on page 276)	RfidRawData	4,121
Total Data Length	RfidTotalLength	5
Operation Type	RfidOpType	5
Field Type	RfidFieldType	4
<p>NOTE: For the RfidRawData field, it is not necessary to set your database field to the maximum size. It is only necessary to set it to the largest data field size of the tags that are being used.</p>		

A *Linux Font Configuration File*

```
# @(#)linux.fontconfig.RedHat.9.0.properties          1.6 03/11/14
# Copyright 2003 Sun Microsystems, Inc. All rights reserved.
# Version
version=1
# Component Font Mappings

allfonts.chinese-gb18030=-misc-zysong18030-medium-r-normal---*-%d---c*-
iso10646-1
allfonts.chinese-gb18030.motif=-isas-song ti-medium-r-normal---*-%d---c*-
gb2312.1980-0
allfonts.chinese-big5=-arphic technology co.-ar pl mingti21 big5-medium-r-
normal---*-%d---c*-iso10646-1
allfonts.chinese-big5.motif=-taipei-fixed-medium-r-normal---*-%d---c*-big5-
0
allfonts.lucida=-b&h-lucidasans-medium-r-normal-sans---*-%d--- p*-iso8859-1

serif.plain.japanese-x0208=-misc-kochi mincho-medium-r-normal---*-%d---c*-
jisx0208.1983-0
serif.plain.korean=-misc-baekmuk batang-medium-r-normal---*-%d---c*-
iso10646-1
serif.plain.korean.motif=-misc-baekmuk batang-medium-r-normal---*-%d---c*-
ksc5601.1987-0
serif.plain.latin-1=-b&h-lucidabright-medium-r-normal---*-%d---p*-iso8859-1
serif.plain.latin-1.motif=-b&h-luxi serif-medium-r-normal---*-%d---p*-
iso8859-1

serif.bold.japanese-x0208=-misc-kochi mincho-medium-r-normal---*-%d---c*-
jisx0208.1983-0
serif.bold.korean=-misc-baekmuk batang-medium-r-normal---*-%d---c*-
iso10646-1
serif.bold.korean.motif=-misc-baekmuk batang-medium-r-normal---*-%d---c*-
ksc5601.1987-0
serif.bold.latin-1=-b&h-lucidabright-demibold-r-normal---*-%d---p*-iso8859-
1
serif.bold.latin-1.motif=-b&h-luxi serif-bold-r-normal---*-%d---p*-iso8859-
1
```

serif.italic.japanese-x0208=-misc-kochi mincho-medium-r-normal---*-%d---c---
jisx0208.1983-0

serif.italic.korean=-misc-baekmuk batang-medium-r-normal---*-%d---c---
iso10646-1

serif.italic.korean.motif=-misc-baekmuk batang-medium-r-normal---*-%d---c---
ksc5601.1987-0

serif.italic.latin-1=-b&h-lucidabright-medium-i-normal---*-%d---p---iso8859-
1

serif.italic.latin-1.motif=-b&h-luxi serif-medium-i-normal---*-%d---p---
iso8859-1

serif.bolditalic.japanese-x0208=-misc-kochi mincho-medium-r-normal---*-%d---c---
jisx0208.1983-0

serif.bolditalic.korean=-misc-baekmuk batang-medium-r-normal---*-%d---c---
iso10646-1

serif.bolditalic.korean.motif=-misc-baekmuk batang-medium-r-normal---*-%d---c---
ksc5601.1987-0

serif.bolditalic.latin-1=-b&h-lucidabright-demibold-i-normal---*-%d---p---
iso8859-1

serif.bolditalic.latin-1.motif=-b&h-luxi serif-bold-i-normal---*-%d---p---
iso8859-1

sansserif.plain.japanese-x0208=-misc-kochi gothic-medium-r-normal---*-%d---c---
jisx0208.1983-0

sansserif.plain.korean=-misc-baekmuk gulim-medium-r-normal---*-%d---c---
iso10646-1

sansserif.plain.korean.motif=-misc-baekmuk gulim-medium-r-normal---*-%d---c---
ksc5601.1987-0

sansserif.plain.latin-1=-b&h-lucidasans-medium-r-normal-sans---*-%d---p---
iso8859-1

sansserif.plain.latin-1.motif=-b&h-luxi sans-medium-r-normal---*-%d---p---
iso8859-1

sansserif.bold.japanese-x0208=-misc-kochi gothic-medium-r-normal---*-%d---c---
jisx0208.1983-0

sansserif.bold.korean=-misc-baekmuk gulim-medium-r-normal---*-%d---c---
iso10646-1

sansserif.bold.korean.motif=-misc-baekmuk gulim-medium-r-normal---*-%d---c---
ksc5601.1987-0

sansserif.bold.latin-1=-b&h-lucidasans-bold-r-normal-sans---*-%d---p---
iso8859-1

sansserif.bold.latin-1.motif=-b&h-luxi sans-bold-r-normal---*-%d---p---
iso8859-1

sansserif.italic.japanese-x0208=-misc-kochi gothic-medium-r-normal---*-%d---c---
jisx0208.1983-0

sansserif.italic.korean=-misc-baekmuk gulim-medium-r-normal---*-%d---c---
iso10646-1

sansserif.italic.korean.motif=-misc-baekmuk gulim-medium-r-normal---*-%d---c---
ksc5601.1987-0

sansserif.italic.latin-1=-b&h-lucidasans-medium-i-normal-sans---*-%d---p---
iso8859-1

sansserif.italic.latin-1.motif=-b&h-luxi sans-medium-i-normal--*-%d--*-%p--
iso8859-1

sansserif.bolditalic.japanese-x0208=-misc-kochi gothic-medium-r-normal--*-%d--
*-%c--jisx0208.1983-0

sansserif.bolditalic.korean=-misc-baekmuk gulim-medium-r-normal--*-%d--*-%c--
*-iso10646-1

sansserif.bolditalic.korean.motif=-misc-baekmuk gulim-medium-r-normal--*-%d--
*-%c--ksc5601.1987-0

sansserif.bolditalic.latin-1=-b&h-lucidasans-bold-i-normal-sans--*-%d--*-%p--
iso8859-1

sansserif.bolditalic.latin-1.motif=-b&h-luxi sans-bold-i-normal--*-%d--*-%p--
*-iso8859-1

monospaced.plain.japanese-x0208=-misc-kochi mincho-medium-r-normal--*-%d--*-%
c--jisx0208.1983-0

monospaced.plain.korean=-misc-baekmuk batang-medium-r-normal--*-%d--*-%c--
iso10646-1

monospaced.plain.korean.motif=-misc-baekmuk batang-medium-r-normal--*-%d--*-%
c--ksc5601.1987-0

monospaced.plain.latin-1=-b&h-lucidatypewriter-medium-r-normal-sans--*-%d--*-%
m--iso8859-1

monospaced.plain.latin-1.motif=-b&h-luxi mono-medium-r-normal--*-%d--*-%m--
iso8859-1

monospaced.bold.japanese-x0208=-misc-kochi mincho-medium-r-normal--*-%d--*-%
c--jisx0208.1983-0

monospaced.bold.korean=-misc-baekmuk batang-medium-r-normal--*-%d--*-%c--
iso10646-1

monospaced.bold.korean.motif=-misc-baekmuk batang-medium-r-normal--*-%d--*-%
c--ksc5601.1987-0

monospaced.bold.latin-1=-b&h-lucidatypewriter-bold-r-normal-sans--*-%d--*-%m--
*-iso8859-1

monospaced.bold.latin-1.motif=-b&h-luxi mono-bold-r-normal--*-%d--*-%m--
iso8859-1

monospaced.italic.japanese-x0208=-misc-kochi mincho-medium-r-normal--*-%d--*-%
*-%c--jisx0208.1983-0

monospaced.italic.korean=-misc-baekmuk batang-medium-r-normal--*-%d--*-%c--
iso10646-1

monospaced.italic.korean.motif=-misc-baekmuk batang-medium-r-normal--*-%d--*-%
*-%c--ksc5601.1987-0

monospaced.italic.latin-1=-b&h-lucidatypewriter-medium-i-normal-sans--*-%d--*-%
*-%m--iso8859-1

monospaced.italic.latin-1.motif=-b&h-luxi mono-medium-i-normal--*-%d--*-%m--
iso8859-1

monospaced.bolditalic.japanese-x0208=-misc-kochi mincho-medium-r-normal--*-%
%d--*-%c--jisx0208.1983-0

monospaced.bolditalic.korean=-misc-baekmuk batang-medium-r-normal--*-%d--*-%
c--iso10646-1

monospaced.bolditalic.korean.motif=-misc-baekmuk batang-medium-r-normal--*-%
%d--*-%c--ksc5601.1987-0

monospaced.bolditalic.latin-1=-b&h-lucidatypewriter-bold-i-normal-sans--*-%d--
*-%m--iso8859-1

monospaced.bolditalic.latin-1.motif=-b&h-luxi mono-bold-i-normal---*-%d---*-%m-
*-iso8859-1

dialog.plain.japanese-x0208=-misc-kochi gothic-medium-r-normal---*-%d---*-%c---
jisx0208.1983-0

dialog.plain.korean=-misc-baekmuk gulim-medium-r-normal---*-%d---*-%c---
iso10646-1

dialog.plain.korean.motif=-misc-baekmuk gulim-medium-r-normal---*-%d---*-%c---
ksc5601.1987-0

dialog.plain.latin-1=-b&h-lucidasans-medium-r-normal-sans---*-%d---*-%p---
iso8859-1

dialog.plain.latin-1.motif=-b&h-luxi sans-medium-r-normal---*-%d---*-%p---
iso8859-1

dialog.bold.japanese-x0208=-misc-kochi gothic-medium-r-normal---*-%d---*-%c---
jisx0208.1983-0

dialog.bold.korean=-misc-baekmuk gulim-medium-r-normal---*-%d---*-%c---
iso10646-1

dialog.bold.korean.motif=-misc-baekmuk gulim-medium-r-normal---*-%d---*-%c---
ksc5601.1987-0

dialog.bold.latin-1=-b&h-lucidasans-bold-r-normal-sans---*-%d---*-%p---iso8859-1

dialog.bold.latin-1.motif=-b&h-luxi sans-bold-r-normal---*-%d---*-%p---iso8859-
1

dialog.italic.japanese-x0208=-misc-kochi gothic-medium-r-normal---*-%d---*-%c---
*-jisx0208.1983-0

dialog.italic.korean=-misc-baekmuk gulim-medium-r-normal---*-%d---*-%c---
iso10646-1

dialog.italic.korean.motif=-misc-baekmuk gulim-medium-r-normal---*-%d---*-%c---
ksc5601.1987-0

dialog.italic.latin-1=-b&h-lucidasans-medium-i-normal-sans---*-%d---*-%p---
iso8859-1

dialog.italic.latin-1.motif=-b&h-luxi sans-medium-i-normal---*-%d---*-%p---
iso8859-1

dialog.bolditalic.japanese-x0208=-misc-kochi gothic-medium-r-normal---*-%d---*-%
*-c---jisx0208.1983-0

dialog.bolditalic.korean=-misc-baekmuk gulim-medium-r-normal---*-%d---*-%c---
iso10646-1

dialog.bolditalic.korean.motif=-misc-baekmuk gulim-medium-r-normal---*-%d---*-%
c---ksc5601.1987-0

dialog.bolditalic.latin-1=-b&h-lucidasans-bold-i-normal-sans---*-%d---*-%p---
iso8859-1

dialog.bolditalic.latin-1.motif=-b&h-luxi sans-bold-i-normal---*-%d---*-%p---
iso8859-1

dialoginput.plain.japanese-x0208=-misc-kochi mincho-medium-r-normal---*-%d---*-%
*-c---jisx0208.1983-0

dialoginput.plain.korean=-misc-baekmuk batang-medium-r-normal---*-%d---*-%c---
iso10646-1

dialoginput.plain.korean.motif=-misc-baekmuk batang-medium-r-normal---*-%d---*-%
*-c---ksc5601.1987-0

dialoginput.plain.latin-1=-b&h-lucidatypewriter-medium-r-normal-sans---*-%d---*-%
*-m---iso8859-1

dialoginput.plain.latin-1.motif=-b&h-luxi mono-medium-r-normal---*-%d---m-
iso8859-1

dialoginput.bold.japanese-x0208=-misc-kochi mincho-medium-r-normal---*-%d---
c---jisx0208.1983-0

dialoginput.bold.korean=-misc-baekmuk batang-medium-r-normal---*-%d---c-
iso10646-1

dialoginput.bold.korean.motif=-misc-baekmuk batang-medium-r-normal---*-%d---
c---ksc5601.1987-0

dialoginput.bold.latin-1=-b&h-lucidatypewriter-bold-r-normal-sans---*-%d---m-
*--iso8859-1

dialoginput.bold.latin-1.motif=-b&h-luxi mono-bold-r-normal---*-%d---m-
iso8859-1

dialoginput.italic.japanese-x0208=-misc-kochi mincho-medium-r-normal---*-%d---
*--c---jisx0208.1983-0

dialoginput.italic.korean=-misc-baekmuk batang-medium-r-normal---*-%d---c-
iso10646-1

dialoginput.italic.korean.motif=-misc-baekmuk batang-medium-r-normal---*-%d---
*--c---ksc5601.1987-0

dialoginput.italic.latin-1=-b&h-lucidatypewriter-medium-i-normal-sans---*-%d---
*--m---iso8859-1

dialoginput.italic.latin-1.motif=-b&h-luxi mono-medium-i-normal---*-%d---m-
*--iso8859-1

dialoginput.bolditalic.japanese-x0208=-misc-kochi mincho-medium-r-normal---*-%
d---*--c---jisx0208.1983-0

dialoginput.bolditalic.korean=-misc-baekmuk batang-medium-r-normal---*-%d---*--
c---iso10646-1

dialoginput.bolditalic.korean.motif=-misc-baekmuk batang-medium-r-normal---*-%
d---*--c---ksc5601.1987-0

dialoginput.bolditalic.latin-1=-b&h-lucidatypewriter-bold-i-normal-sans---*-%d-
----m---iso8859-1

dialoginput.bolditalic.latin-1.motif=-b&h-luxi mono-bold-i-normal---*-%d---*--
m---iso8859-1

Search Sequences

sequence.allfonts=latin-1 sequence.allfonts.Big5=latin-1,chinese-big5

sequence.allfonts.GB2312=latin-1,chinese-gb18030

sequence.allfonts.x-euc-jp-linux=latin-1,japanese-x0208

sequence.allfonts.EUC-KR=latin-1,korean sequence.allfonts.GB18030=latin-
1,chinese-gb18030

sequence.fallback=lucida,chinese-big5,chinese-gb18030,japanese-x0208,korean

Exclusion Ranges

exclusion.japanese-x0208=0390-03d6,2200-22ef,2701-27be

Font File Names

filename.-arphic_technology_co.-ar_pl_mingti2l_big5-medium-r-normal---*-%d---
*--c---iso10646-1=/usr/share/fonts/zh_TW/ TrueType/bsmi001p.ttf

```
filename.-misc-baekmuk_batang-medium-r-normal--*-%d-*-*c*-iso10646-  
=/usr/share/fonts/ko/TrueType/batang.ttf  
filename.-misc-baekmuk_gulim-medium-r-normal--*-%d-*-*c*-iso10646-  
1=/usr/share/fonts/ko/TrueType/gulim.ttf  
filename.-misc-kochi_gothic-medium-r-normal--*-%d-*-*c*- jisx0208.1983-  
0=/usr/share/fonts/jā/TrueType/kochi-gothic.ttf  
filename.-misc-kochi_mincho-medium-r-normal--*-%d-*-*c*- jisx0208.1983-  
0=/usr/share/fonts/jā/TrueType/kochi-mincho.ttf  
filename.-misc-zysong18030-medium-r-normal--*-%d-*-*c*- iso10646-  
1=/usr/share/fonts/zh_CN/TrueType/zysong.ttf
```

```
# AWT X11 font paths
```

```
awtfontpath.latin-1=/usr/X11R6/lib/X11/fonts/Type1 awtfontpath.chinese-  
big5=/usr/share/fonts/zh_TW/TrueType awtfontpath.chinese-  
gb18030=/usr/share/fonts/zh_CN/TrueType awtfontpath.japanese-  
x0208=/usr/share/fonts/ja/TrueType  
awtfontpath.korean=/usr/share/fonts/ko/TrueType
```

Contact Information

Printronix Auto ID Customer Support

The Printer Place 708-597-4222
www.theprinterplace.com

